

See discussions, stats, and author profiles for this publication at: <https://www.researchgate.net/publication/338129083>

# Design and Futures

Book · December 2019

CITATIONS

0

READS

3

49 authors, including:



**Stuart Candy**

Carnegie Mellon University

31 PUBLICATIONS 115 CITATIONS

[SEE PROFILE](#)



**Ahmed Ansari**

Carnegie Mellon University

12 PUBLICATIONS 9 CITATIONS

[SEE PROFILE](#)



**Nik Baerten**

Pantopicon

9 PUBLICATIONS 34 CITATIONS

[SEE PROFILE](#)



**Jake Franklin Dunagan**

California College of the Arts

19 PUBLICATIONS 62 CITATIONS

[SEE PROFILE](#)

Some of the authors of this publication are also working on these related projects:



Transition Ojai [View project](#)



AFR-OT project: nOna, Arts Centre Mechelen [View project](#)

***DESIGN  
AND  
FUTURES***

***EDITED BY  
STUART CANDY  
& CHER POTTER***

# ***DESIGN AND FUTURES***

***EDITED BY STUART CANDY  
AND CHER POTTER***

Tamkang University Press  
Taipei

Published by Tamkang University Press  
Graduate Institute of Futures Studies, Tamsui, Taipei, Taiwan 251

Editors' Note: This is a single-volume compilation and reissue of the two publications listed below. Contents, pagination and referencing are unchanged.

Design and Futures, Volume I  
Journal of Futures Studies, 23(3), March 2019  
Design and Futures, Volume II  
Journal of Futures Studies, 23(4), June 2019

The Journal of Futures Studies is a globally-oriented, transdisciplinary refereed journal. Its mission is to develop high-quality, futures-oriented research and thinking, based on the evolving knowledge base of Futures Studies / Foresight.

All contributions © 2019 the authors  
This compilation and layout v1.1, December 2019  
[jfsdigital.org](http://jfsdigital.org)

ISBN 978-1-70999-008-3

# CONTENTS

## DESIGN AND FUTURES, Volume I

### Editors' Introduction (Vol. I)

*Stuart Candy and Cher Potter* ..... 1

### ARTICLES

#### Turning Foresight Inside Out:

#### **An Introduction to Ethnographic Experiential Futures**

*Stuart Candy and Kelly Kornet* ..... 3

#### **Politics of Designing Visions of the Future**

*Ramia Mazé* ..... 23

#### **Crafting Spaces Between Design and Futures:**

#### **The Case of the Agboglobhie Makerspace Platform**

*Cher Potter, DK Osseo-Asare, and Mugendi K. M'Rithaa* ..... 39

#### **Strategic Foresight Studio:**

#### **A First-Hand Account of an Experiential Futures Course**

*Jake Dunagan, Alida Draudt, JJ Hadley, Ryan Hogan,  
Leticia Murray, Gregory Stock, and Julia Rose West* ..... 57

#### **Designing Futures From the Inside**

*Anne Burdick* ..... 75

## **ESSAYS AND INTERVIEWS**

### **How the Future Happens**

*James Auger and Julian Hanna* ..... 93

### **Critical Activism**

*Anab Jain and Stuart Candy* ..... 99

### **Storytelling Shapes the Future**

*Alex McDowell* ..... 105

### **I Design Worlds**

*Liam Young and Stuart Candy* ..... 113

### **Anticipating Future System States**

*Jamer Hunt* ..... 119

### **A Manifesto for Decolonising Design**

*Decolonising Design Collective: Danah Abdulla, Ahmed Ansari,  
Ece Canli, Mahmoud Keshavarz, Matthew Kiem, Pedro Oliveira,  
Luiza Prado, and Tristan Schultz* ..... 129

## **DESIGN AND FUTURES, Volume II**

### **Editors' Introduction (Vol. II)**

*Stuart Candy and Cher Potter* ..... 1

## **ARTICLES**

### **Destinations for Polyamorous Futures and Their MAD Lovers**

*Maya van Leemput* ..... 3

### **Worldbuilding in Science Fiction, Foresight and Design**

*Leah Zaidi* ..... 15

<b>SPACECRAFT: A Southern Interventionist Art Project</b>	
<i>Ralph Borland</i> .....	27
<b>Are We (Really) Designing Futures?</b>	
<b>The Design of Tomorrow Program at CENTRO</b>	
<i>Karla Paniagua</i> .....	37
<b>A Futures-Design-Process Model for Participatory Futures</b>	
<i>Stefanie A. Ollenburg</i> .....	51
<b>Imagining 2060:</b>	
<b>A Cross-Cultural Comparison of University Students' Perspectives</b>	
<i>Jeanne Hoffman</i> .....	63
<b>Transforming Environmental Values for a Younger Generation in Taiwan: A Participatory Action Approach to Curriculum Design</b>	
<i>Kuo-Hua Chen</i> .....	79

## **ESSAYS AND INTERVIEWS**

<b>You Never Know How the Past Will Turn Out</b>	
<i>Timothy Morton</i> .....	97
<b>Design in the Future</b>	
<i>Paola Antonelli and Cher Potter</i> .....	101
<b>Making Things Physical</b>	
<i>Maja Kuzmanovic, Tina Auer, Nik Gaffney, and Tim Boykett</i> .....	105
<b>Napkin Futures: Fragments of Future Worlds</b>	
<i>Nik Baerten</i> .....	117
<b>Change the Model</b>	
<i>Dan Hill and Stuart Candy</i> .....	123
<b>What If There Were More Policy Futures Studios?</b>	
<i>Lucy Kimbell</i> .....	129

**Your Move: Lessons Learned at the Interstices of Design, Gaming,  
and Futures**

*Aaron Rosa and John A. Sweeney* ..... 137

**Using the Future at NASA**

*David Delgado and Stuart Candy* ..... 143

**Post-Island Futures: Designing for Uncertainty in a Changing Climate**

*Lizzie Yarina* ..... 149

**Starting at the End: A Journey in Time**

*Tony Fry* ..... 159

***DESIGN AND FUTURES***  
***Volume I***



# Introduction to the Special Issue: Design and Futures (Vol. I)

**Stuart Candy**  
**Carnegie Mellon University**  
**USA**

**Cher Potter**  
**University of the Arts London**  
**Victoria and Albert Museum**  
**UK**

As Nobel Laureate Herbert Simon famously observed: “Everyone designs who devises courses of action aimed at changing existing situations into preferred ones” (Simon, 1996).

Designers and futurists, it turns out, have a great deal in common. This mutual recognition is reaching critical mass as each comes to appreciate how their respective traditions have much to offer to making urgent change in the world, and even more so, together.

It is increasingly acknowledged within the futures studies community that operating with a largely verbal and theoretical bent over the past half century has afforded too little impact on actual future-shaping behaviours. Meanwhile, those in the design community recognise a need to interrogate higher-level consequences – the futures, the worlds – that their products, systems and other outputs help produce.

Part of what bringing design and futures into sustained dialogue does is to allow each field to become more fluent in a second language which is the other’s native tongue.

How may designers systematically map out preferred futures, and what frameworks might futures studies furnish to help them? Conversely, how might futures scholars and practitioners adopt designerly modes of exploration, working more materially, visually and performatively to instantiate and illuminate possibilities?

‘Design and futures’ together offer ecosystemic and embodied approaches to shaping our collective prospects, informed by a diverse range of practices.

We are excited to have been working with the Journal of Futures Studies over several years to bring readers a special double issue dedicated to ‘Design and Futures’.

In this first issue, Vol. I, we have five peer-reviewed articles: Stuart Candy and Kelly Kornet introduce a new framework engaging communities and individuals in tangible forms of speculation. Ramia Mazé argues for the significance of how political dimensions suffuse futures thought. Cher Potter, DK Osseo-Asare and Mugendi M’Rithaa analyse the worldviews embedded in a makerspace platform in Accra, Ghana. Jake Dunagan offers an account of teaching experiential futures, written in collaboration with a whole class of graduate students. Anne Burdick shows how a multilayered experiment around developing a storyworld, characters, prototypes, and plot, delineates a rich design space scaffolded by a simultaneously narrative, conceptual, and material brief.

Powerful shorter contributions by speculative designers James Auger and Julian Hanna, design futurist Anab Jain, Hollywood worldbuilder Alex McDowell, architect Liam Young, design scholar Jamer Hunt, and

the geographically-distributed Decolonising Design Collective round out a remarkable first cross-sectional scan of design and futures perspectives.

In the next issue, Vol. II, curators, strategic designers, policymakers, and philosophers join the conversation.

As guest editors of this special edition, we wish to thank all authors who submitted articles and essays, and also the peer reviewers who so generously gave their time.

Our own practices originate in futures and design studies respectively, but we have both been actively 'hybridising' for a while now. In promoting such entanglements more widely, we aim to offer readers across both communities, and well beyond, insight into how disparate perspectives and tools, in combination, can challenge, remix, and strengthen each other, as well as open on to further exchange.

Of the immensely exciting community weaving that is underway where futures and design meet, these pages represent just some initial strands. We foresee many more to come.

## Correspondence

Stuart Candy  
Carnegie Mellon University  
USA  
E-mail: scandy@cmu.edu

Cher Potter  
University of the Arts London  
Victoria and Albert Museum  
UK  
E-mail: c.j.potter@arts.ac.uk

## References

Simon, H. A. (1996) [f.p. 1969]. *The Sciences of the Artificial* (3rd ed.) Cambridge, MA: MIT Press, p. 111.

# Turning Foresight Inside Out: An Introduction to Ethnographic Experiential Futures

Stuart Candy  
Carnegie Mellon University  
USA

Kelly Kornet  
Kalypso  
Canada

---

## Abstract

*This article contributes to emerging hybrid design/futures practices by offering an orienting framework making images of the future more legible and concrete. The Ethnographic Experiential Futures (EXF) Cycle provides, practically, a way of inviting engagement with diverse participants, and methodologically, a generic process drawing on two traditions of foresight (ethnographic and experiential futures), with a view to promoting a more diverse and deeper array of scenarios for public consideration. The structure of the EXF Cycle is derived from hybrid efforts carried out by design/futures practitioners over some years, abstracted as scaffolding to serve future projects in a wide range of contexts.*

**Keywords:** Action Research, Design Fiction, Ethnography, Experiential Futures, Integral Futures, Intermediary Knowledge, Scenarios, Speculative Design.

---

“The image must first be received before it can be broadcast.”

Frederik L. Polak, *The Image of the Future*.

“The future is inside us / It’s not somewhere else.”

Radiohead, “The Numbers”.

## Introduction

Just south of Sarnia, Ontario (pop. 70,000), the largest city on Lake Huron, is a place called Chemical Valley. It is home to forty per cent of the petrochemical industry for the whole of Canada (Vice, 2013) — a nation of 35 million — and also to the worst air quality in the country (MacDonald & Rang, 2007). The areas

adjacent to such industrial hotspots, called “sacrifice zones” or “fence-line communities” (Bullard, 2005, p. 85), are typically populated by less politically influential groups; the socioeconomically disadvantaged; people of colour; indigenous communities.

Kelly Kornet, a researcher who had grown up nearby, wanted to gain an understanding of the thinking and motivations of environmental activists from places like Chemical Valley; “how individuals living in conditions of environmental toxicity develop the ability to imagine possible futures and take positive action in their communities.” (Kornet, 2015, p. 3) In one-on-one interviews, participants were invited to speak about the kinds of futures that they expected, hoped for, and feared. That stage alone may have sufficed for some valuable forms of traditional analysis, but for this project Kornet was interested in opening up the issues to a wider audience, and as a trained designer, in animating these narratives with the skills at her disposal. So once articulated verbally, participants’ divergent futures were materialised in a selection of future artifacts as if they had actually come to pass. This meant creating props, as it were, from the movies in their minds: the industrial accident that they worried could occur at the plant; the laws that they hoped local authorities would properly enforce to restore air and water quality (see Image 1). These were shared at a small exhibition in Toronto, *Causing an Effect*, to which research collaborators and the general public were both welcomed and invited to respond (Kornet, 2015).

Here the designer served a dual role: as a futures researcher eliciting det M e□

## I. Images of the Future

Critical futures scholarship argues that ‘the future’ does not exist as such, but is inherently a domain of ideation and imagination. It “cannot be experienced directly, but only through images, thoughts, feelings and the multiple ways these are subsequently expressed in the outer world” (Slaughter, 2018, p. 444). Sociologists Barbara Adam and Chris Groves capture the challenge well: “[E]ngagement with the future is an encounter with a non-tangible and invisible world that nevertheless has real and material consequences” (Adam & Groves, 2007, p. xv). Accordingly a central challenge for futures consists in ‘making the invisible visible and tangible.’

The concept of ‘images of the future’, a kind of mental and cultural construct influential in the unfolding of history, was proposed by sociologist Fred Polak years before futures began to coalesce as a field (Polak, 1973 [1955]), and it has provided part of the foundation on which generations of scholars and practitioners have worked since.<sup>1</sup> As Dator observes: “These images often serve as the basis for actions in the present. ... Different groups often have very different images of the future. ... [O]ne of the main tasks of futures studies is to identify and examine the major alternative futures which exist at any given time and place” (Dator, 2005).

In the mid-1970s Robert Textor, a younger associate of the great Margaret Mead, and a self-described sociocultural anthropologist and futurist (Textor, 2003, p. 521) based at Stanford University, began to turn attention in this direction. Textor pioneered *anticipatory anthropology*, “the use of anthropological knowledge and ethnographic methods, appropriately modified and focused, to anticipate change” (Textor, 1985, p. 4). He saw its value in terms of confronting a pair of more or less ubiquitous ills: “*ethnocentrism* refers to one’s being excessively centred in one’s own culture, and *tempocentrism* to one’s being excessively centred in one’s own timeframe.” (Textor in Mead, 2005, pp. 16-17, emphasis added). Ethnocentrism is more widely recognised – its web search results dwarf those of tempocentrism by three orders of magnitude<sup>2</sup> – but the latter represents at least as pervasive a psychological and cultural pathology.

Ethnographic Futures Research, developed by Textor and his students, is a valuable if today often overlooked methodological entryway into this challenging space, offering a process for systematically mapping images of the future held by various individuals and communities. “Just as the cultural anthropologist conventionally uses ethnography to study an extant culture, so the cultural futures researcher uses EFR to elicit from members of an extant social group their images and preferences (cognitions and values) with respect to possible or probable future cultures for their social group.” (Textor, 1980, p. 10) A semi-structured interview format is used to draw out participants’ projections. “Instead of simply asking ‘What do you believe is going to happen?’, in EFR you ask: ‘Within the context of overall trends and possibilities as you perceive them, what potential changes in your sociocultural system do you (1) want, (2) fear, and (3) expect?’” (Veselsky & Textor, 2007, pp. 31-32).

Textor is careful not to be misunderstood as positing a singular future (Textor, 1980, p. 10), and in this he underlines the ontological and epistemological pluralism of the field. Indeed it is a key tenet of EFR, and of the futures tradition we are working in, that every person contains multitudes.<sup>3</sup>

Relatedly, we put the EXF Cycle forward in a spirit of methodological pluralism: EFR’s version of ethnography for studying futures is useful, but is not set on a pedestal as the best or only way to do so. Only two of the five cases outlined below use that particular approach.

Thus EFR is one way to try rendering people’s futures ‘visible’ in words. But what happens when we take the challenge of making particular futures ‘tangible’ seriously? It is this challenge that leads to the concatenation of ‘ethnographic’ inquiry with experiential futures.

Experiential Futures (XF) is a family of approaches for making futures visible, tangible, interactive, and otherwise explorable in a range of modes. Led by practice and accompanied by a growing theoretical base,<sup>4</sup> XF is grounded in the big-picture agenda of contributing to a social

capacity for foresight (Slaughter, 1996), using material and performative registers to build on the field’s traditional uses of theoretical, schematic and verbal exploration (Candy, 2010; Raford, 2012; Kelliher & Byrne, 2015; Selin, 2015). The turn to experience, as a canvas for futures practice, prods at a traditional overreliance in the field on words, and corresponding underutilisation of other media (Ramos, 2006), disclosing a transmedia landscape of alternative ways to use the future. More embodied and media-rich depictions of futures, argue proponents, can make the field more effective in shaping change (Candy, 2010; Candy & Dunagan, 2017). The practitioners and projects of XF are highly intertwined with those of design-led futures-oriented activities which have come into prominence over the same period, since the mid-2000s, including speculative design and design fiction (Dunne & Raby, 2013; Montgomery & Woebken, 2016; Durfee & Zeiger, 2017; Candy & Dunagan, 2017). Yet the task of enhancing futures thinking is medium-agnostic — the best approach is whatever it takes (Candy, 2010, p. 111) — and so Experiential Futures exhibits great variety in terms of the media and engagement strategies used. This can be seen in the examples described in Section II.

## II. Five Projects

This section outlines in broad strokes a diverse set of projects that share structural resemblances in combining ‘ethnographic’ and ‘experiential’ elements.

### Project 1: Causing an Effect

Kelly Kornet worked with lifelong environmental activists from fence-line communities, using EFR interviews to explore their hoped for, feared and expected futures, and subsequently applying design skills to fabricate physical artifacts ‘from’ the futures they described (e.g., Image 1). The resulting exhibition let her gather responses from some original participants, as well as from a wider public (Kornet, 2015).



Image 1. Artifact from a participant’s preferred future, where local environmental regulations maintain air and water quality more effectively / Design & Photo: Kelly Kornet

## Project 2: FoundFutures (Chinatown)

In the mid 2000s, futurists Stuart Candy and Jake Dunagan ran a series of informal experiments deploying ‘future artifacts’ to the public on an unsolicited basis. They called the approach ‘guerrilla futures’ by analogy with guerrilla theatre, marketing, art, and semiotics (Candy, 2010, pp. 208-257). Initial gestures such as ‘droplifting’ future products into local shops (Candy, 2007) paved the way to *FoundFutures: Chinatown*, a more systematic effort to bring futures to life at the scale of a community; Honolulu’s Chinatown, on Oahu, Hawaii. Bringing backgrounds in anthropology and theatre, they orchestrated artifact deployments and enactments from a series of imaginaries for the neighbourhood, grounded in the particulars of place and history. The set of scenarios was generated after interviewing area residents and business-owners, and then translated into urban installations and happenings (Dunagan & Candy, 2007).



*Image 2.* Part of an experiential scenario about gentrification in Honolulu’s Chinatown / Project directors: Stuart Candy and Jake Dunagan / Artwork: Mark Guillermo / Photo: Matthew Stits

Gentrification concerns were dramatised through signage heralding the (then-unprecedented) arrival of American franchises such as Starbucks and TGI Fridays, and luxury apartments (see Image 2). Another intervention, inspired by the outbreaks of bubonic plague in Chinatown in the early 20th century, hypothesised an epidemic of “Hang Ten” flu. A third posed the question: what becomes of Chinatowns in a future where China is the preeminent superpower? Reactions were registered via direct observation, as well as in the press, and at a free community workshop (Dunagan & Candy, 2007).

## Project 3: Making the Futures Present

Designer and interactive narrative professor Maggie Greyson has developed a framework for ‘personal experiential futures’ to help people more concretely picture their possible future selves

and circumstances, drawing partly on EFR and partly on ‘personal futures’ practice (Wheelwright, 2009; Draudt & West, 2016).

The process entails interviewing volunteer participants one on one about a range of scenarios they can imagine facing on a 20-year time horizon in their own lives; positive, negative, and expected, and then ‘unexpected’, too. Not part of EFR’s descriptive protocol, the latter is added to probe, challenge or expand prospective thinking. In the same session, researcher and participant co-create rapid prototypes from selected futures (see Image 3), and afterwards the host goes on to develop more polished, real-looking artifacts as a basis for deeper conversation at their next meeting (Greyson, 2016).



*Image 3.* Rapid prototyping of ‘personal experiential futures’ artifacts / Project design & Photo: Maggie Greyson

#### **Project 4: 1-888-FUTURES**

A series of day-long participatory design workshops was staged by researchers from Situation Lab and The Extrapolation Factory in the mid-2010s.<sup>5</sup> Hosted at the University of Southern California’s School of Cinematic Arts in Los Angeles, *1-888-FUTURES* solicited public input in the weeks prior by inviting people to call a toll-free number and record their future dream in a voicemail, together with a mailing address (Situation Lab, 2015).

On the day, workshop participants were assigned a random voicemail to retrieve as the basis for a ‘tangibilisation’ (Chris Woebken’s excellent word) of the dream. (See Image 4.) The makers then recorded a video explaining how the dream recording had inspired their ‘future present’, and boxed it up to send to the provided address. Afterwards, on social media, some recipients would post responses to the artifact they had opened.



*Image 4.* Design jam participants ponder how to bring voicemail-recorded dreams to life / Project design: Extrapolation Factory and Situation Lab / Photo: Stuart Candy

### **Project 5: Futureproof**

Conor Holler is a management consultant with a background in improvisational comedy, who undertook a design project to research how it can be used for more serious purposes. ‘Improv’ is a long standing theatrical tradition (Johnstone, 1981; Halpern, Close & Johnson, 1994) recently fashionable among businesses seeking to enhance their creativity (Kulhan & Crisafulli, 2017). Holler devised an improv format which put topic experts and actors together in front of a live audience, to create scenes from ‘possible futures’. “*Futureproof* explores improv’s potential to contribute positively to futures practice, with XF work serving as its main conceptual and methodological reference point” (Holler, 2017, p. 3).

The guest expert in genetics, for instance, is invited onstage to describe how genetic technologies might figure in everyday life a generation from now (see Image 6). The host and actors ask some questions, then the players improvise a series of scenes from futures inspired and informed by the opening, for both audience and expert to react to.



Image 5. Conor Holler introduces the guest expert and performers at the premiere of *Futureproof*, Bad Dog Theatre, Toronto / Photo: Stuart Candy

Though disparate these examples share a kind of structure under the surface. In a sense, they could have been formulated by attending to the phases set out in the next section.

### III. Surfacing a Structure

Ethnographic Experiential Futures (EXF) emerged from the cases outlined above, initially using *Causing an Effect* as a model. The steps taken there were:

1. The researcher maps her collaborators' images of the future through one-on-one semi-structured interviews.
2. The researcher draws from the interviews to mediate some concrete experiential expression of scenic ideas in them.
3. Realising the opportunity to make these images accessible to a wider audience and create space for dialogue, she shares or mounts the experiential scenario for people to encounter.

This workflow appears in Figure 1.



Figure 1. A preliminary outline of the generic sequence of phases for *Causing an Effect*.

Some projects added scenarios alongside those described by participants, when researchers wanted to expand the set available for consideration (*FoundFutures*; *Making the Futures Present*).

In support of a more comprehensive discourse, the researcher may introduce, or co-create, some alternative future(s) to extend, challenge, diversify, or in a word multiply those originally described.

Pluralising or multiplying futures being an important structural feature of foresight work, here it is an optional phase between mapping and mediating participants' thinking, hence the modified outline in Figure 2.



Figure 2. Our picture of the generic process evolved after noticing an often valuable, but optional, stage

At a glance now, the three (or four) phases describe an arc from narrative elicitation to experiential expression, and could appear complete. But these projects, in contrast to much speculative design/design fiction, specifically attempt to gauge impact.<sup>6</sup>

The researcher gathers or, once again, **maps** feedback and responses arising from the intervention.

With this follow-up visit to the inner landscape of futures thinking, taking stock of how it has been (perhaps) changed, perturbed or deepened by the intervention, the process circles back to the first stage. Now it may be summarised as follows:

**Map<sub>1</sub>**: Inquire into and record people’s actual or existing images of the future (probable; preferred; non-preferred; a combination).

**Multiply**: Generate alternative images (scenarios) to challenge or extend existing thinking (optional, especially in first iteration).

**Mediate**: Translate these ideas about the future/s into experiences; tangible, immersive, visual or interactive representations.

**Mount**: Stage experiential scenario/s to encounter for the original subject/s or others, or both.

**Map<sub>2</sub>**: Investigate and record responses.

This recasts the shape from an arc into a loop or cycle (Figure 3). In principle, it could be repeated any number of times: a first iteration might document anchoring narratives such as those that EFR seeks to capture, while subsequent rounds could challenge or revise them.

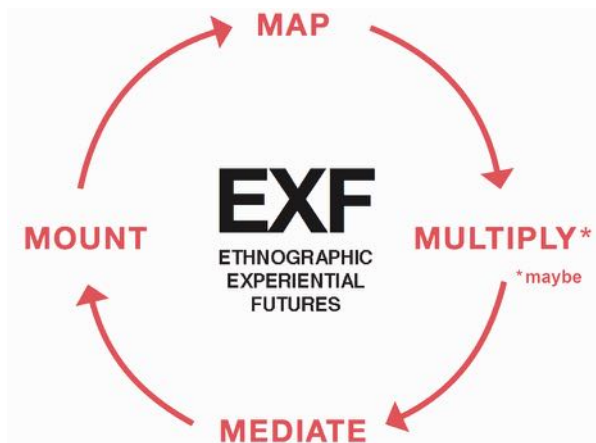

Figure 3. The EXF Cycle

Across diverse goals, media and contexts, a range of projects can be described in terms of the EXF Cycle despite their not having been created using it. Table 1 shows how the architecture of each project reflects the phases identified.

Soon after sharing the draft framework at the Design/Develop/Transform Conference in Brussels (Candy & Kornet, 2017), we encountered a humanitarian activist initiative about girls in Syrian refugee camps being supported in imagining their own futures (Hutchison, n.d.). *Vision Not Victim* had originated in entirely different circumstances tied to neither the futures field nor design,

Table 1. *Five projects broken into EXF phases*

	(1) Causing an Effect (Kornet, 2015)	(2) Found Futures: Chinatown (Dunagan & Candy, 2007)	(3) Making the Futures Present (Greyson, 2016)	(4) 1-888-FUTURES (Situation Lab, 2015)	(5) Futureproof (Holler, 2017)
MAP <sub>1</sub>	Elicit images of the future from individual activists using EFR.	Talk to locals and research neighbourhood history for relevant leads and resonant episodes.	Interview participants in workshop to elicit images of the future, using EFR as a backbone.	Public call for brief recordings of people's "dreams" (images of the future); prompted by an automated voice menu.	Invite a subject matter expert to describe possible future scenarios in their area of expertise (genetics, buildings, etc).
MULTIPLY	Step intentionally omitted.	Generate a mix of location-specific future scenarios addressing different issues and trajectories identified as significant for the neighbourhood.	Formulate and probe for an unexpected possible future as well.	Step intentionally omitted.	Actors may be prompted to inflect the scenes they are about to play towards different kinds of scenario, for example, using Dator's generic images of the future (grow, collapse, discipline, transform).
MEDIATE	Derive concrete artifacts from the described scenarios.	Collaborate with a series of art/design teams (one per scenario) to create artifacts, particularly print matter like posters and flyers, "from" the future scenarios.	Create prototype artifacts from selected scenario(s) in the same session in partnership with the participant; then go away and make a higher-resolution version.	Hold a free design jam where participants/ makers (a) pick up a message, (b) fill in a "packing slip", and (c) use an array of provided objects and construction materials to make the dream tangible.	Have actors generate a series of scenes on the fly, responding to and exploring the expert's imaginary, described at the top of the show.
MOUNT	Show the designed objects in an exhibition setting.	Stage or "install" the future artifacts in situ over several weeks (non-overlapping) so people in the area have the chance to stumble across them in the course of ordinary life.	Bring in high-res artifact to next interview.	Have participants/ makers record a short video as part of the event, describing the 'dream' voicemail and showcasing the 'future present' made in response; and packing it up to ship to the address left in the original voicemail.	In improv (i.e., performance that is not scripted but rather created entirely moment-to-moment onstage), Mediate and Mount are effectively merged into a single step.
MAP <sub>2</sub>	Capture responses from the activist-participants, as well as the audience.	Gather reactions via observation, press coverage, and a free public workshop focusing on the neighbourhood's futures.	Discuss and capture participant response to the high-res artifact.	Note responses posted by recipients via social media when their future presents arrive in the mail.	Seek feedback from both expert and audience on the futures they have just witnessed.

yet followed the same trajectory (Candy, 2017), underscoring how the structure might genuinely be useful for traversing a wide project design space. To test out that proposition required sharing it more broadly, which is what this article is for.

We now turn to situating the framework in more depth, and considering some of its potentials and hazards.

## IV. Discussion

In this section we explore the uses and variations of EXF, but first it will be helpful to locate the work in a wider context and clarify what we are trying to do.

### Situating

#### (a) In relation to futures research

In terms of our primary lens of futures research, we have noted how EXF brings ethnographic and experiential traditions together, spurred in part by a recently articulated methodological need in foresight to enable design-driven “circumstances or situations in which the collective intelligence and imagination of a community can come forth” (Candy & Dunagan, 2017, p. 150).

Foresight scholars often study images of the future that individuals or groups hold (Eckersley, 1997; Hicks, 2002; Hutchinson, 1996; Ono, 2005; Tonn, Hemrick, & Conrad, 2006; Rubin, 2013).<sup>7</sup> They may use scalable quantitative instruments such as questionnaires and surveys, or more qualitative and narrative-based approaches such as essays and focus groups.<sup>8</sup> However, rarely are these futures expressed in a form other than words.

Conversely, the explorations of possible futures emanating from design tend to give form to their creators’ own narrative ideas (Dunne & Raby, 2013; Durfee & Zeiger, 2017), whereas EXF projects incorporate map *as well as* mediate images of the future, such that the imaginative ‘source materials’ come from participants, and lead to results quite unlike speculative design’s typical technology-first provocations.

We mean to invite a considered connection between these two operations that are not usually thought about in a joined-up way, let alone carried out together.

This work is approximately aligned with the ‘critical and emancipatory’ register identified by historian Elke Seefried (2014, p. 4), and partakes also of the ‘participatory/prospective’ and ‘integral/holistic’ traditions outlined by Jennifer Gidley (2017, p. 64). However, EXF is perhaps best described using a typology lucidly set out in recent work by Jose Ramos, as a protocol for ‘futures action research’ (Ramos, 2017, pp. 825–827). In other words we are not concerned with trying to establish foreknowledge of what the future will be, but with helping a nascent design/futures community to extend critical and participatory foresight work into a deeply embodied mode, by scaffolding processes to more effectively explore the futures thinking of diverse communities, using design (meant broadly here) to loop from an interior register to an exterior — thinkable, feelable, discussable — one.

Moreover, any project following the EXF Cycle potentially tackles a need highlighted in ‘integral futures’ scholarship, to span interior and exterior, individual and collective ways of knowing (Slaughter, 2008).

#### (b) In relation to design research

Like futures, the design field is also undergoing rapid transformation to better address its potential to shape change at scale. As Bruce and Stephanie Tharp note in their work on ‘discursive design’ — a genus only recently identified, and a term perhaps more apt than speculative design or design fiction for the various species of project that EXF describes; “If design is going to begin

closing the gap between its present and a greater future, the typical designer will be required to stretch a little more intellectually” (Tharp & Tharp, 2019, p. 19).

In design methodology language, EXF is a framework for ‘research through design’ (Frayling, 1993; Gaver, 2012), noting especially Bill Gaver’s insistence that design “is a generative discipline, able to create multiple new worlds rather than describing a single existing one. Its practitioners may share many assumptions about how to pursue it, but equally, they may build as many incompatible worlds as they wish to live in” (Gaver, 2012, p. 943). One finds a similar orientation in critical futures, for instance Ashis Nandy’s wonderful notion of the field as “a game of dissenting visions” (Nandy, 1996, p. 637).

Equally, there are resonances in Liz Sanders and Pieter-Jan Stappers’s description of ‘generative design research’ as “giv[ing] people a language with which they can imagine and express their ideas and dreams for future experience. These ideas and dreams can, in turn, inform and inspire other stakeholders in the design and development process” (Sanders & Stappers, 2012, pp. 8;14).

Thanks to recent conceptual work in interaction design and human-computer interaction literature, we might characterise the EXF Cycle as an example of ‘intermediary knowledge’ (Höök & Löwgren, 2012; Dalsgaard & Dindler, 2014; Höök *et al.*, 2015). The framework sits between the concrete specificity of particular designs (the five projects) and the more abstract register of theories (such as the question of how images of the future bend the arc of history). Through this lens the value of EXF comes from forging ‘lateral’ connections among prior projects (e.g. Table 1), in a variation on the design research approach described by Gaver as the “annotated portfolio” (Gaver, 2012, p. 944), as well as ‘vertical’ connections between these specific cases and the EXF ‘structure’ identified as overarching them, thereby delineating a larger design space (including many more possible projects), and onward to those higher-order questions of how futures thinking circulates in communities and influences change. Stated briefly like this, there is the risk of appearing to dispense too quickly with matters that could take up much more of our attention – but this is precisely the point: the generative, intermediary knowledge object opens up further fronts of designerly and scholarly investigation.

It remains for later work to trace connections more fully with the growing design anthropology literature (Gunn, Otto, & Smith, 2013; Smith *et al.*, 2016); and also with those works presenting ethnographic (or similar) investigations of particular imaginaries, for example feminist (Schalk, Kristiansson, & Mazé, 2017) and afrofuturist (Brooks, 2016; Imarisha & brown, 2015). These worthy endeavours sit at a tangent to our principal aim of extending a resource and invitation to futures practitioners and designers interested in making real-world forays into the hybrid arena of experiential futures, by providing handrails and heuristics for orientation and guidance.

## Structuring

What kind of orientation and guidance does EXF provide? We have seen that each stage of the cycle – Map, Multiply, Mediate, Mount, and Map again – admits of wide variation. This may make for strange juxtapositions but it also points towards the power of a framework intended to be flexible. The questions one asks at each stage might be quite similar, but the answers could be as different as their futurist/ designer/ researcher/ participant co-creators see fit.

In this section, then, we suggest how each step can be used to open numerous generative questions for practitioners, so helping shape the design of these hybrid projects.

### (a) Map<sub>1</sub>

Whose futures are being explored, and why? Are individual, personal-scale mental models especially of interest, or those of a group or community? If the latter, who speaks for the community? What are the elicitation strategies – in writing or interview, in person or remotely, with how much scaffolding and of what kinds? When might existing evidence of future images suffice?

Research collaborators in the cases outlined represent multiple demographics: some of the sort perhaps conventionally orbiting relatively wealthy, Western university-based participatory design projects and invited subject-matter experts; but alongside the usual suspects are residents of a traditionally ethnic-minority urban neighbourhood and environmental activists from fence-line and First Nations communities.

It is exciting to consider how projects to come could partner with and be activated by many more kinds of stakeholder.

In discussing this Mapping phase, we acknowledge potential objections in some quarters to the term ‘ethnography’ being used so flexibly — perhaps less where EFR is deployed than where imaginative contributions are more rapid or playful. There is a certain license in describing an improvisational theatre format in terms of ethnography, and although it is beyond our scope to weigh in on the contested question of what should count as ethnography (Markham, 2018), we repeat that our aim is to support attempts to animate and embody futures thinking in many contexts. Ethnographic depth is for us a design parameter; a spectrum to be throttled up and down as circumstances require, rather than as a fixed boundary to be drawn and policed in the same way at all times. On the spectrum of depth some projects might be located in the middle ground (*FoundFutures*), and one starts to see how certain kinds of inquiry (conversation with neighborhood residents who might not have much time to spare) could be less effective, or practically prohibited, with a stricter approach. This spectrum view, together with the imperative that format be crafted to fit the case, comports with our aim of enabling not simply *more*, but appropriate, activity in this design space. It might seem strange to say, but rigour or depth are not an unalloyed scholarly good to be maximized at any cost; they are part of a dynamic project design landscape in which more of one thing (e.g. time spent with informants) is bound to mean less of something else (e.g. access for certain participants).

So for initial mapping, EFR could be used, but less formal portals will sometimes be appropriate, be they voicemails from the public or the ruminations of a subject live onstage. One method seemingly well suited to mapping futures in projects to come is Causal Layered Analysis (Inayatullah, 1998), useful for analyzing (Hurley, 2008) and also generating (Kaboli & Tapio, 2018) in-depth images of the future.

### **(b) Multiply**

Should the initially found images of the future be specifically challenged, diversified and expanded? And if so, on a first pass, or later — and in which directions?

To supplement a first set of futures images is an optional variation in the process. One might omit where the goal is to consider primary ‘extant’ futures (like the activists’ motivating narratives in *Causing an Effect*), or where the diversity of the original inputs meets requirements (like the dozens of voicemails recorded by the public ahead of *1-888-FUTURES*).

The key underlying question, often the case in futures practice, is which future stories need to be told, regardless of how they are arrived at or framed — ‘surfaced’ from prior thought, co-created from scratch, or something else.

### **(c) Mediate**

How, where, and when can the future(s) be brought to life? Whose responsibility is it in the project setup? Might participants be able to manifest their own future concepts directly?

This step is about taking relatively vague ideas or future narratives toward more concrete ones. As our examples suggest, there are myriad ways to make this move, from hybrid design/research exhibition, to rapid prototyping, guerrilla art installation, and improv theatre. Techniques and formats for producing experiential scenarios — ‘situations’ and ‘stuff’ from times to come — are covered elsewhere; in particular the Experiential Futures Ladder may offer relevant scaffolding for

this stage (Kornet, 2015, pp. 67–68; Candy & Dunagan, 2016).

There may seem to be a notion in play that people necessarily need help to bring their futures thinking to life – casting the futurist/designer/researcher as coming to the rescue with superior representational skills. This is not our assumption. While it may be true in some cases, aside from the obvious parameter of medium or format for expression, the other central question in the ‘mediate’ step is how collaboration is set up. ‘Design’ responsibility might sometimes be located with the researchers (as in the artifacts made for *FoundFutures* and *Causing an Effect*), or more with participants (a kind of ‘autoethnographic’ experiential scenario creation is integral to *Making the Futures Present*), or with third parties (*Futureproof*; *1-888-FUTURES*).

EXF starts with Mapping because that is where futures work usually starts, and too often, ends as well. But in some cases direct nonverbal mediation could be a starting point — such as hand-drawn (pictorial) images of the future (used by Candy in introductory foresight courses for designers), or the recent Turkish study of children’s paintings of potential future technologies (Şeker & Şahin, 2012), or still-life tableaux created on the spot by workshop participants in the emancipatory theatre practice of Augusto Boal (e.g. “the image of transition” in Boal, 1992, p. 173). These quick and dirty representations may be more symbolic than diegetic in how they invoke the future; potentially rich fodder for discussion when ‘mapping’ to close the loop.

#### (d) Mount

How, when, where and for whom is the experiential scenario made available?

What it means to Mount an EXF project depends on what and how one chooses to Mediate. These are not neatly separate variables. An improv theatre scene (or Boal tableau) Mediates and Mounts an experiential scenario all at once; there is literally no distinction. But they are separated in the framework because in some formats they are intrinsically different design choices, so the creation of artifacts from a particular future could occur at one point, and be staged for an audience much later.

Of course the circumstances in which a person ‘meets’ the future can vary considerably — a scripted environment like a workshop (*Making the Futures Present*) is quite different from an unscripted one like a city street (*FoundFutures*), or a private one (future presents received in the mail after *1-888-FUTURES*). There may sometimes be a single ‘mounting’ event overlaying multiple constituencies (*Causing an Effect*), and capturing the responses of multiple different groups to a given experiential scenario may be highly illuminating.

#### (e) Map<sub>2</sub>

At last, and connected to all of the above, how best to Map responses to the experiential scenario? Whose responses are in scope? Is there the possibility, or need, to bring different views into dialogue, and if so how? Are they to be recorded formally or informally; live or online; privately or with others present; from a captive audience or a parade of passers-by?

A rigorous research approach may call for interviews with the original informants (*Causing an Effect*; *Making the Futures Present*) or a questionnaire filled by an audience (*Futureproof*). Less demanding of participants might be direct observation of those having the futures encounter (*FoundFutures*), monitoring of public responses online (*1-888-FUTURES*), or opt-in feedback mechanisms (like the blackboard prompts inviting visitors’ reactions at *Causing an Effect*).

The closing of a cycle may be quite another matter from its opening, with the circumstances of a particular encounter (and thus capture of responses) sometimes being dramatically different from those at the start. Still, the range of options here, including depth and rigour required, can be usefully compared to those in ‘Map<sub>1</sub>’ above.

## Conclusion

This article has offered a pattern for hybrid design/futures projects in a kind of action research cycle, pairing moves to surface people's images of the future with moves to deepen the scenarios in play. In examples shared, agendas vary from academic experimentation to documentary, activist, and public deliberation purposes, as well as more personal, quasi-therapeutic, and outright playful ones.

Going forward we picture not only cultural and social foresight-oriented projects being extended, but also uses in more formal and institutional contexts such as businesses, classrooms, governments, and nonprofits. Some of this has already begun, and can be explored in work to come.

For the most part, the projects seen here circle just once, but if pursued past a preliminary pass, the learning loop (or feedforward) shape of EXF could let all parties refine and track evolving images of the future over time. This raises the prospect of supporting social foresight through ongoing community elaboration and deliberation of alternatives — for example, tied to a public election cycle, or to participatory organisational governance. So appears part of the potential for a pattern structurally echoing action research, experiential learning, and iteration in design (Kolb, 2015; Ramos, 2017; Zimmerman, 2003).

Meanwhile, in navigating the framework details and variations in this setting, we must take care not to lose sight of the human heart of the matter: people often find it difficult to think about the future (Tonn et al., 2006), and even in supposedly advanced democracies, often our aspirations and motivating narratives are not present or legible to one other in any form, let alone in idioms designed to “create empathy and build understanding for the perspectives of others” (Kornet, 2015, p. 98), bring the “disruptive energy of laughter” (Holler, 2017, p. viii), or combine “interactive interviews, deep listening, systems thinking and prototyping together” (Greyson, 2016, p. 143).

To end by recalling our motivation, building on some key ideas of the futures field: the development of new and compelling ways of turning foresight inside out appears critical if humanity is to have any chance of developing a distributed social capacity to think ahead; if we hope to escape our tempocentrism, come to better understand each other, and navigate change together. It is our hope that, with this intermediary knowledge framework, others will discover variations that currently cannot be foreseen: We look forward to what a community of EXF experimenters will generate.

*The authors wish to express appreciation for the contributions of all collaborating parties in the projects described, especially Jake Dunagan, Maggie Greyson, Conor Holler, and Helen Kerr. For valuable comments and conversations thanks also to Anne Burdick, Christian Crews, Dan Lockton, Jose Ramos, Roger Rouse, Wendy Schultz, Peter Scupelli, and two anonymous peer reviewers.*

## Correspondence

Stuart Candy  
Carnegie Mellon University  
USA  
E-mail: scandy@cmu.edu

## Notes

1. Polak's influence is likely underrated (van der Helm, 2005).
2. A google search for 'ethnocentrism' returns 3,130,000 results; 'tempocentrism' receives 2,040, and the variant 'temporocentrism' has 3,170. Retrieved February 24, 2019.

3. We also acknowledge the co-constructed nature of these imaginaries, where the researcher/designer is involved.
4. *The Sceptical Futuryst* blog documents the emergence of experiential futures dating back to 2006: <https://futuryst.blogspot.com>
5. Situation Lab is run by Stuart Candy and Jeff Watson <http://situationlab.org>; The Extrapolation Factory is run by Elliott Montgomery and Chris Wobken <http://www.extrapolationfactory.com>
6. Some trenchant criticism of speculative/critical design work hinges on a perceived lack of interest, on the part of its makers, in actual as opposed to intended effects (Tonkinwise, 2015).
7. For decades, pioneering futures educator Jim Dator would have incoming futures students each write two short essays, envisioning their lives, and their communities, 25 years out (Troumbley, Yim, & Frey, 2011).
8. The collaboration *Maono*, undertaken with urban youth and artists in Democratic Republic of the Congo, is a notable exception (Van Leemput, 2015).

## References

- Adam, B., & Groves, C. (2007) *Future matters: Action, knowledge, ethics*. Leiden, The Netherlands: Brill.
- Boal, A. (1992). *Games for actors and non-actors* (2nd ed). (Trans. by A. Jackson). Routledge: London.
- Boulding, E. (1988) Building a global civic culture: Education for an interdependent world. Syracuse, NY: Syracuse University Press.
- Brooks, Lonny Avi. 2016. "Playing a Minority Forecaster in Search of Afrofuturism: Where Am I in This Future, Stewart Brand?" In: Anderson and Jones (eds.), *Afrofuturism 2.0: The Rise of Astro-Blackness*. Lanham, MD: Lexington Books, pp. 149-166.
- Bullard, R.D. (2005). *The quest for environmental justice: Human rights and the politics of pollution*. Sierra Club Books: San Francisco.
- Candy, S. (2007, October 1). More found futures. *The Sceptical Futuryst* <https://futuryst.blogspot.com/2007/09/more-found-futures.html>
- Candy, S. (2010). *The futures of everyday life: Politics and the design of experiential scenarios* (PhD Dissertation). Department of Political Science, University of Hawaii at Manoa.
- Candy, S. (2017, June 28). Syrian refugee girls imagine their futures. *The Sceptical Futuryst*. <https://futuryst.blogspot.com/2017/06/syrian-refugee-girls-imagine-their.html>
- Candy, S., & Dunagan, J. (2016). The experiential turn. *Human Futures*, 1, 26–29. [https://www.researchgate.net/publication/311910011\\_The\\_Experiential\\_Turn](https://www.researchgate.net/publication/311910011_The_Experiential_Turn)
- Candy, S., & Dunagan, J. (2017). Designing an experiential scenario: The people who vanished. *Futures*, 86, 136–153.
- Candy, S., & Kornet, K. (2017). A field guide to ethnographic experiential futures. Design/Develop/Transform Conference. Brussels, Belgium, June 15.
- Dalsgaard, P., & Dindler, C. Between theory and practice: Bridging concepts in HCI research. *Proceedings of CHI 2014*, pp. 1635–1644.
- Dator, J. (2005). Foreword. In: R. Slaughter (Ed.), *The knowledge base of futures studies* (Electronic resource; 5 Vols.) Indooroopilly, Queensland: Foresight International.
- Draudt, A., & West, J. R. (2016). *What the foresight*. CreateSpace.
- Dunagan, J., & Candy, S. (2007). *Foundfutures: Chinatown – Community futures initiative*. Report submitted to the Hawaii Arts Alliance. <https://www.scribd.com/doc/298048071/Dunagan-and-Candy-2007-FoundFutures-Chinatown>
- Dunne, A., & Raby, F. (2013). *Speculative everything: Design, fiction, and social dreaming*. Cambridge, MA: MIT Press.

- Durfee, T., & Zeiger, M. (Eds.). (2017). *Made up: Design's fictions*. New York: ArtCenter Graduate Press / Actar.
- Eckersley, R. (1997). Portraits of youth: Understanding young people's relationship with the future. *Futures*, 29(3), 243–249.
- Escobar, A. (2018). *Designs for the pluriverse: Radical interdependence, autonomy, and the making of worlds*. Durham, NC: Duke University Press.
- Frayling, C. (1993). Research in art and design. *Royal College of Art Research Papers*, 1(1), 1–5.
- Gaver, W. (2012). What should we expect from research through design? *Proceedings of CHI 2012*, pp. 937–946.
- Gidley, J. M. (2017). *The future: A very short introduction*. Oxford: Oxford University Press.
- Greyson, A. H. M. (2016). *Making the futures present* (MDes Project). Faculty of Design, OCAD University. <http://openresearch.ocadu.ca/id/eprint/1441/>
- Gunn, W., Otto, T., & Smith, R. C. (Eds.) (2013). *Design Anthropology: Theory and Practice*. London: Bloomsbury.
- Halpern, C., Close, D., & Johnson, K. (1994). *Truth in comedy: The manual for improvisation*. Colorado Springs, CO: Meriwether Publishing.
- Hicks, D. (2002). *Lessons for the future: The missing dimension in education*. London: Routledge-Falmer.
- Holler, C. P. (2017). *The experiential futures of futureproof: A format for improvising future scenarios* (MDes Project). Faculty of Design, OCAD University. <http://openresearch.ocadu.ca/id/eprint/1987/>
- Höök, K., & Löwgren, J. (2012). Strong concepts: Intermediate-level knowledge in interaction design research. *ACM Transactions on Computer-Human Interaction*, 19(3), 23:1–18.
- Höök, K., Dalsgaard, P., Reeves, S., Bardzell, J., Löwgren, J., Stolterman, E., & Rogers, Y. (2015). Knowledge production in interaction design. *Proceedings of the 33rd Annual ACM Conference Extended Abstracts on Human Factors in Computing Systems*, pp. 2429–2432.
- Hurley, K. (2008). Is that a future we want?: An ecofeminist exploration of images of the future in contemporary film. *Futures*, 40, 346–359.
- Hutchinson, F. P. (1996) *Educating Beyond Violent Futures*. London: Routledge.
- Hutchison, M. (n.d.). Vision not victim program – Syrian refugees. *Meredith Hutchison Photography*. <http://www.meredithhutchisonphotography.com/2546343-vision-not-victim-jordan>
- Imarisha, W., & Brown, A. M. (Eds.) (2015). *Octavia's brood: Science fiction stories from social justice movements*. Oakland, CA: AK Press.
- Inayatullah, S. (1998). Causal layered analysis: Poststructuralism as method. *Futures*, 30(8), 815–829.
- Johnstone, K. (1981). *Impro: Improvisation and the theatre*. London: Methuen.
- Kaboli, S.A., & Tapio, P. (2018). How late-modern nomads imagine tomorrow? A causal layered analysis practice to explore the images of the future of young adults. *Futures*, 96, 32–43.
- Kelliher, A., & Byrne, D. (2015). Design futures in action: Documenting experiential futures for participatory audiences. *Futures*, 70, 36–47.
- Kolb, D. (2015). *Experiential learning: Experience as the source of learning and development* (2nd ed.) Upper Saddle River, NJ: Pearson Education.
- Kornet, K. (2015). *Causing an effect: Activists, uncertainty and images of the future* (MDes Project). Faculty of Design, OCAD University. <http://openresearch.ocadu.ca/id/eprint/257/>
- Kulhan, B., & Crisafulli, C. (2017). *Getting to "yes and": The art of business improv*. Stanford, CA: Stanford University Press.
- MacDonald, E., & Rang, S. (2007). *Exposing Canada's Chemical Valley: An investigation of cumulative air pollution emissions in the Sarnia, Ontario area*. Toronto: Ecojustice.
- Markham, A. N. (2018). Ethnography in the Digital Internet Era: From Fields to Flows, Descrip-

- tions to Interventions. In: N.K. Denzin & Y.K. Lincoln (Eds.), *The Sage handbook of qualitative research* (5th ed.) Thousand Oaks, CA: Sage, pp. 650–669.
- Mead, M. (2005). *The world ahead: An anthropologist anticipates the future* (Robert B. Textor, ed.). New York: Berghahn Books.
- Montgomery, E., & Woebken, C. (2016). *Extrapolation Factory: Operator's Manual*. CreateSpace.
- Nandy, A. (1996). Bearing witness to the future. *Futures*, 28(6-7), 636–639.
- Ono, R. (2005). Societal factors impacting on images of the future of youth in Japan. *Journal of Futures Studies*, 9(4), 61–74.
- Plowman, T. (2003) Ethnography and critical design practice. In: B. Laurel (Ed.). *Design research: Methods and perspectives*. Cambridge, MA: MIT Press, pp. 30–38.
- Polak, F. (1973) [1955]. *The image of the future* (trans. and abridged by Elise Boulding). Amsterdam: Elsevier.
- Raford, N. (2012). From design fiction to experiential futures. In: A. Curry (Ed.), *The future of futures*. Houston, TX: Association of Professional Futurists.
- Ramos, J. (2006). Consciousness, culture and the communication of foresight. *Futures*, 38, 1119–1124.
- Ramos, J. (2017). Linking foresight and action: Toward a futures action research. In: L.L. Rowell, et al. (Eds.). *The Palgrave international handbook of action research*. New York: Palgrave Macmillan, pp. 823–842.
- Rubin, A. (2013). Hidden, inconsistent, and influential: Images of the future in changing time. *Futures*, 45, 38–44.
- Schalk, M., Kristiansson, T., & Mazé, R. (2017). *Feminist futures of spatial practice: Materialisms, activisms, dialogues, pedagogies, projections*. Baunach, Germany: AADR/Spurbuchverlag.
- Seefried, E. (2014). Steering the future: The emergence of “Western” futures research and its production of expertise, 1950s to early 1970s. *European Journal of Futures Research* 15:29. doi: 10.1007/s40309-013-0029-y
- Şeker, B. S., & Şahin, G. G. (2012). Images of future technology generated by primary school students through their paintings. *Procedia – Social and Behavioral Sciences*, 55, 178–186.
- Selin, C. (2015). Merging art and design in foresight: Making sense of Emerge. *Futures*, 70, 24–35.
- Situation Lab (2015). *1-888-FUTURES*. <http://situationlab.org/project/1-888-futures/>
- Slaughter, R. A. (1996). How to develop a social foresight capacity. In: H.F. Didsbury Jr. *Futurevision: Ideas, insights, and strategies*. Bethesda, MD: World Future Society, pp. 88–100.
- Slaughter, R. A. (1998). Futures beyond dystopia. *Futures*, 30(10), 993–1002.
- Slaughter, R. A. (2008). What difference does ‘integral’ make? *Futures*, 40, 120–137.
- Slaughter, R. A. (2018). Two fine additions to the futures literature. *Foresight*, 20(4), 443–446. doi: 10.1108/FS-08-2018-098
- Smith, R. C., Vangkilde, K. T., Kjaersgaard, M. G., Otto, T., Halse, J., & Binder, T. (Eds.) (2016). *Design Anthropological Futures*. London: Bloomsbury.
- Textor, R. B. (1980). *A handbook on ethnographic futures research* (3rd ed., Version A). Stanford, CA: Stanford University.
- Textor, R. B. (1995). The ethnographic futures research method: An application to Thailand. *Futures*, 27(4), 461–471.
- Textor, R. B. (2003). Honoring excellence in anticipatory anthropology. *Futures*, 35, 521–527.
- Textor, R. B., et al. (1985). Anticipatory anthropology and the telernicroelectronic revolution: A preliminary report from Silicon Valley. *Anthropology & Education Quarterly*, 16, 3–30.
- Tharp, B. M., & Tharp, S. M. (2019) *Discursive design: Critical, speculative, and alternative things*. Cambridge, MA: MIT Press.
- Tonkinwise, C. (2015, August 21). Just design. *Medium*. <https://medium.com/@camerontw/just-design-b1f97cb3996f>

- Tonn., B., Hemrick, A., & Conrad, F. (2006). Cognitive representations of the future: Survey results. *Futures*, 38, 810–829.
- Troumbley, R., Yim, S., & Frey, H. (2011). The Future in 25 Years, 1976–1989: Continuities, cycles, and novelties. Paper presented at 21st World Futures Studies Federation Conference / Global Higher Education Forum, Penang, Malaysia, December 13–15.
- Van der Helm, R. (2005). The future according to Frederik Lodewijk Polak: Finding the roots of contemporary futures studies. *Futures*, 37(6), 505–519.
- Van Leemput, M. (2015). Grass-roots images of futures about the global south. In: A. Hatakka & J. Vehmas (Eds). *Sustainable futures in a changing climate*. Turku: Finland Futures Research Centre (FFRC), pp. 154–166.
- Veselsky, E. E., & Textor, R. B. (2007). The future of Austria: A twenty-year dialog. *Futures Research Quarterly*, 23(4), 23–56.
- Vice Staff (2013, August 8). The Chemical Valley. *Vice*. [https://www.vice.com/en\\_us/article/4w-7gwn/the-chemical-valley-part-1](https://www.vice.com/en_us/article/4w-7gwn/the-chemical-valley-part-1)
- Wheelwright, V. (2009). Futures for everyone. *Journal of Futures Studies*, 13(4), 91–104.
- Yelavich, S., & Adams, B. (2014). *Design as future-making*. London: Bloomsbury.
- Yorke, T. *et al.* (2016) The Numbers. [Recorded by Radiohead]. On *A Moon Shaped Pool* [MP3 file]. London: XL Records.
- Zimmerman, E. (2003). Play as research: The iterative design process. In: B. Laurel (Ed.). *Design research: Methods and perspectives*. Cambridge, MA: MIT Press, pp. 176–184.



# Politics of Designing Visions of the Future

Ramia Mazé  
Aalto University  
Finland

---

## Abstract

*Scenarios for policy and the public are increasingly given form by designers. For design, this means ideas about the future – futurity – is at stake, particularly in genres of ‘concept’, ‘critical’ and ‘persuasive’ design. While critical approaches are present in futures studies and political philosophy, design assumptions and preferences are typically not explicit, including gender norms, socio-ecological practices and power structures. Calling for further studies of the politics of design visions, I outline possible approaches and elaborate through the example ‘Switch! Energy Futures’. I reflect upon how competing visions and politics of sustainability become explicit through our process, aesthetics and stakeholders.*

**Keywords:** Futures Studies, Design, Design Theory, Visualization, Scenarios, Political Philosophy.

---

## Introduction

The future – indeed, temporality – has only entered substantially into design discourse relatively recently. Design and other disciplines such as architecture, geography and geology have long been preoccupied with space rather than with time (Grosz, 1999; Mazé, 2007). Today, however, ideas about the future – or, in philosopher Elizabeth Grosz’ terms, *futurity* – is stake in many design arguments and practices. Assumptions about time, progress and futurity underlie popular rhetoric concerning ‘change’, ‘progress’, ‘transformation’ and ‘transition’, and design, along with many disciplines, is affected by the increasing hegemony of values framed as ‘newness’ and ‘innovation’ (e.g. Wakeford, 2014). Beyond mere rhetoric, design research and practice must further develop its approaches to futurity.

Indeed, the future is itself might be conceived as a design problem (Reeves, Goulden, & Dingwall, 2016). Some classic conceptions of design are premised upon the future – for example in the formulation by Herbert Simon: “Everyone designs who devises courses of action aimed at changing existing situations into preferred ones” (1996, p. 130) thereby “addressing differences between the desired and the present” (1996, p. 141). Particular ideas or ideals of the future are mobilized by socially- and politically-engaged designers (e.g. Ericson & Mazé, 2011), by ‘redirective’ designers addressing “defuturing” phenomena such as climate change (Fry, 2010), and by ‘transition’ designers (Irwin, 2015; Mazé, Gregory, & Redström, 2011). As evident in this journal issue, genres of ‘design futures’ are amassing an increasing number of examples, theoretical depth and public

exposure. Possible, probable and preferred futures are explicitly addressed in ‘concept’, ‘critical’ and ‘persuasive’ design practices that produce powerful visions of the future.

Design relations to futurity are expanding, and so are alliances with the field of futures studies. In Europe, futures studies has grown with a public awareness of issues such as climate change (for example, energy featured strongly in the development of the field in Sweden, see Höjer, 2010) and public demand for understanding and participating in long-term national policies (Vergragt, 2012). With the rise of public communication and deliberation of policy as well as more participatory forms of governance and planning, design has become a powerful discipline charged with visualizing such futures in accessible, popular and persuasive forms (e.g. Ilstedt & Wangel, 2013; Pipkin, 2016; Vergragt, 2010). Design visioning and prototyping of futures has been crucial for rendering previously textual analyses (such as policy scenarios) and abstract concepts (such as “sustainability”) in forms available for empirical (i.e. bodily) experience and public deliberation (cf. Candy, 2014; Mazé & Önal, 2010).

Such designed visions of the future, along with their preferences, norms and ideals, shape policy planning, market economies and cultural imaginaries. This entails that there is much at stake in the expanding intersection between the disciplines of design and futures studies.

An enduring example of the power of design envisioning ideas of time, memory and the future is *acceptera*, the first manifesto of Swedish Modern design (Åhrén et al., [1931] 2008). *Acceptera* evoked, in text, image and proposed designs, a modern, or future, ‘A-Europe’, “The society we are building for”, versus ‘B-Europe’, or ‘Sweden-then’, fragmented spatially, temporally and socially. A-Europe is premised on a standardized society, allowing for industrialization at all levels, from that of large-scale communications networks to the micro and minor practices of local farming, leisure activities and domestic work. Other values, customs, peoples and cultures were portrayed as regressive and stuck across past centuries. *Acceptera* is a manifesto for development in a predetermined direction, created on the basis of a modernist understanding of time, progress and linear causality, a specific arrow of time premised on industrial technologies and industrial design, leading to a particular, and singular, societal future.

The politics of the future envisioned in *acceptera* were explicit – it was distributed by the publishing branch of Sweden’s Social Democratic political party, and it has had profound and lasting effects on the ideological and socio-material construction of the Swedish welfare state (Mattsson & Wallenstein, 2010).

However, the politics of many designed visions of the future are not explicit. While rhetoric of ‘the new’ and preferred futures pervade design, other temporal phenomena such as ‘chance’, ‘indeterminacy’ and the ‘untimely’ seem less welcome (Grosz, 1999). This implies certain selections – and political dimensions – within design concern for futurity. The ‘arrow of time’ in *acceptera* was directed not to any possible future but to a specific and preferred future reality with political intent. Whether it is made explicit or not within design, identifying and making a difference between what is real, now, and what is, or is not, negotiable or preferable in the future is a political act (Mazé, 2016). In this article, I call for developing approaches to query and make explicit the assumptions and preferences underlying designed visions of the future, including design roles in (re)producing or countering social norms, practices and structures. This is particularly urgent given the expansion of such visions into policy and the public sphere.

## Political Dimensions of Futurity

There are many possible political dimensions of futurity in design and futures studies. By ‘political’ here, I refer here to philosophical and analytical uses of the term rather than the macro-politics of state sovereignty or organized party politics. In a philosophical sense, political dimensions of futurity can include how reality and futurity are conceived, how present and future

phenomena can be known, and what difference our conceptions, knowledges and choices make.

In terms of how reality and futurity are conceived, for example, we can query an ontology of time structured in the three categories of past, present and future. Indeed, this tripartite ontology can itself be queried as a historically- and culturally-specific assumption (Adam & Groves, 2007). Concepts of ‘the future’ scarcely exist in some cultures, as argued by futures researcher Sohail Inayatullah (1990). Other philosophies of time instead explore notions of emergence, becoming and virtuality (e.g. Bergsonian time in Grosz, 1999), and feminist and postcolonial theories counter universalizing narratives of time (e.g. Harding, 2008; Mazé & Wangel, 2017). Within the field of futures studies, such ontological questions underpin genres of ‘critical-postmodern’ futures studies (Gidley, Fien, Smith, Thomsen, & Smith, 2009; Inayatullah, 1990), which may interrogate the nature of time, the hegemonic tripartite structure of time, modern and Western paradigms of clock time, linear progression and positivist predictability (Adam, 2008). A fundamental political dimension in futures studies and design, therefore, is the ontology and conception of time that is assumed and (re)produced.

If we choose to operate within a Western and modern conception of time, including an assumption that ‘the future’ exists, further political dimensions surface. Conceiving of the future as something that exists means that it can be posited as an object of scientific study, as something that can be known. This motivates a basic epistemological dilemma discussed by futures researchers, since knowledge in futures studies lacks the empirical basis of other disciplines (or deals with ontological uncertainties, see Svenfelt, 2010; Wangel, 2012). In design research, as in futures research, we can endlessly debate what can be known, methods of knowledge production, issues of uncertainty and indeterminability, and we can get stuck in the knowledge politics and institutional histories between scientific disciplines (Höjer, 2010).

Facing this dilemma, we can end by (more or less unconsciously) reproducing certain scientific logics that have socio-political ramifications. Indeed, the predominance of technocentric and positivist logics in futures studies is, at least in part, the result of such reproduction (Inayatullah, 1990). Such futures studies have tended to imagine the future as technological and material only, portraying the future as a discrete and definite location which might be arrived at through linear transition pathways along which the development of particular technologies as the privileged baseline for plotting human, cultural and societal ‘progress’ (if social factors are considered at all, e.g. Wangel, 2011). Scenarios and visions of the future premised on such logics continue to permeate futures studies and design. As futures researcher Josefin Wangel argues (referring to Adam, 2008), “this is perpetuated by research paradigms premised on positivist ideas of cause-effect chains and prognoses that advocate ‘evidence-based planning and design’, or future projection based on those things that can be known through measurement and aggregation” (Mazé & Wangel, 2017, p. 276).

Reproducing certain scientific logics, for example by privileging those things that can be known through measurement, excludes some phenomena. Phenomena such as social and cultural practices, psychological and biophysical dynamics, and socio-ecological events are less amenable to measurement and prediction, except within the most experimentally contained and limited contexts. This may partly explain why ‘probable’, ‘possible’ and ‘preferable’ future logics alike are largely devoid of explicit explorations of the social (Wangel, 2011). Indeed, as futures researcher Ulrika Gunnarsson-Östling (2011) has established, futures studies images and activities are largely devoid of women and non-Westerners as well as feminist issues or issues of particular relevance to women. Critical study of even ‘radical’ futures studies, e.g. backcasting studies for sustainable development, reveals that the social side of society is assumed to go on more or less according to ‘business as usual’ (Wangel, 2011). The exclusion of particular phenomena produces a political effect concerning the consideration and, thus, the representation and prioritization of certain genders, peoples and species within futures studies.

While there are efforts to address this dilemma as a question of more and better methods, there is an epistemological limit to what can be known about the future. For futures researcher Jerome Glenn, this dilemma suggests that the core question of futures studies should not be “How well do you know it?” but, rather, “What difference does it make?” (Glenn & Gordon, 2003, p.8). “What difference does it make?” articulates further political dimensions concerning intention and application for particular (political) purposes. As Inayatullah articulates, “every planning effort involves philosophical assumptions as to what is considered immutable and what is negotiable; the significant and the trivial. Thus, every effort to plan the future is submerged in an overarching politics of the real” (Inayatullah, 1990, p. 116). Positing that things can be different opens for political questions concerning what or who can, or should, be present, and how, in the future, as well as what can, or should, change, what difference that makes, and for whom.

These political dimensions outlined in relation to futures studies are increasingly relevant for design. Indeed, it is often through designed scenarios and visions that futures studies take form within policy, planning and the public sphere. Thus, political questions are not only relevant to the content development of scenarios and visions but to the designed forms of rhetoric through which they are represented, materialized, communicated and deliberated. Further, and more fundamentally, positing the future as a design problem, as inherent within design activity, or as an explicit objective of design entails that questions posed within philosophies of time and within futures studies are also relevant to design.

A further potential of design relates to the epistemological dilemma indicated above. Contemporary philosophers concerned with futurity argue that dominant scientific modes or forms of knowing cannot grasp critical aspects of the future. Aligned with discussions about ideas and politics concerning ‘difference’ raised by such futures researchers, Grosz, for example, poses a potential of futurity that is given precisely by the ontological assumption that the future is different. It is, categorically, not the past nor the present. Exploring notions of ‘the possible’ in Henri Bergson’s philosophy, she queries the future as other than a “preformed version of the real” (Grosz, 2001, p. 12). Further, she argues, “if dominant modes of knowledge (causal, statistical) are incapable of envisioning the absolutely new, maybe other modes of knowing, other forms of thinking, need to be proposed” (Grosz, 1999, p. 21). Along with Grosz, historian and philosopher of art and architecture John Rajchman (1999) calls for another “art of seeing and acting” than those preoccupied with future causalities or determinisms, prophesy or prediction. They suggest the arts, including design, as other ways of coming to know, experience and relate to futurity.

## Approaches to Designed Visions of the Future

While political dimensions of futurity in design remain largely inexplicit and unquestioned, there are some relevant concepts and approaches. For example, and relevant to the forms through which policy is communicated, design has been theorized as ‘political rhetoric’. Design theorist Richard Buchanan draws on classical Greek political philosophy to account for design as political rhetoric, arguing that “rhetoric is an art of shaping society, changing the course of individuals and communities, and setting patterns for new actions... designers have directly influenced the actions of individuals and communities, changed attitudes and values, and shaped society in surprisingly fundamental ways” (1989, p. 93). As political rhetoric, this positions design as inherently concerned with shaping society in particular, preferred ways.

Among various types of rhetoric, Buchanan is explicitly concerned with political or deliberative rhetoric, wherein the goal is to induce certain beliefs about the future. As he articulates, “design is an art of thought directed to practical action through the persuasiveness of objects and, therefore, design involves the vivid expression of competing ideas about social life” (Buchanan, R. (1989, p. 94). Since there are rarely singular solutions to human problems (or futures), design activity

involves choices and makes arguments about human relations and societal organization, issues more typically located within the realm of politics proper and to study within the social and political sciences. Design, as Buchanan and others argue (e.g. Winner, 1995; Mazé, 2007; Fry, 2010; Dilnot, 2015), is inevitably ideological, and, in (re)producing particular future forms of social life and society, design activity has inherent political dimensions.

In design practice, rhetoric of futurity is prominent in various genres, even if political dimensions are not made explicit. For example, the future is at stake in ‘concept design’, ‘critical design’ and ‘persuasive design’, as well as in other genres not further elaborated here such as ‘speculative design’, ‘design futures’ and ‘transition design’. As I discuss elsewhere (Mazé, 2007), concept design, critical design and persuasive design are not definitive categories in design discourse, since examples are not easily or exclusively identified and terminologies are highly contingent, and since positions are continually renegotiated and reframed. For explanatory purposes here, these are elaborated in (over-)general terms, as tropes through which to discuss ways in which design may aspire or claim to project, challenge and steer the future, in order to expose some political dimensions.

‘Concept design’ flourishes in trade shows and world expositions, for example in the form of prototypes of the ‘ideal home’, ‘future city’, ‘concept car’ and ‘The World of Tomorrow’ (e.g. Rydell & Schiavo, 2010). In a similar vein, Philips Electronics’ *Vision of the Future* (Baxter, 1996) and other industrial and strategic design programs fuse forecasting, sociology and high-tech research in concept designs. Concept designs have become central to business strategies building shared values and commitments, expanding and marketing the ‘corporate imagination’ within a company, an industrial sector or a target group. Foresight may be essential for industries that depend on a twenty-year lifespan (Gabrielli & Zoels, 2003), however such genres go well beyond technical questions of lifespan. Concept design induces desire and (re)produces cultural imaginaries for particular industrial futures.

Allied with art, ‘critical design’ (as a niche within product and interaction design that can also be more widely and historically positioned, see Mazé, 2007; Mazé & Redström, 2009) produces artifacts that debate futures. Resisting the ‘dreams of industry’, Anthony Dunne and Fiona Raby (2001, cf. Spiller 2006) borrow strategies of defamiliarization and estrangement from modernist aesthetics to provoke debate about current norms, ‘alternative nows’ or ‘speculative futures’. Critical designs are intended as “material theses”, physical rather than written critiques, of established models of production and consumption (Seago & Dunne, 1999). Designs are crafted, placed and photographed carefully, often in exclusive settings such as art museums, coffee table books and lifestyle or culture inserts in the media. While opposing traditional models of design industry, such designs nevertheless seem to assume and prefer a particular socio-economic niche.

‘Persuasive design’ for behavioral change aims to redirect norms. In the area of sustainability, for example, ideals, consequences or futures around electricity and water consumption are monitored and visualized in forms intended to educate, persuade, incentivize or even coerce change in perceptions and ‘good’ behavior (Bohle, 2012; Verbeek & Slob, 2006). Designed to ‘fit’ people’s bodies and sensory capacities, or cognitive and emotional ergonomics, such approaches steer behavioral change in more or less conscious ways. Persuasive designs induce self-discipline, regulating, affirming and ‘governing’ particular behaviors in forms intended to be internalized and reinforced in an ongoing manner in everyday life and social practices (Mazé, 2013b). While perhaps not always aware or reflexive about the ideologies and policies (re)produced, persuasive designs oppose present conditions and propose quite particular alternatives and futures.

Concept, critical and persuasive design are far from neutral. Concept design, for example, identifies and selects particular trends and values to extrapolate and amplify imagined ‘ideal’ futures of the home, car or city. There are endless socio-economic and techno-material possibilities, and choices are made about which may or may not be identified, reproduced or changed (see Wangel,

2012, for a discussion of preferred and normative futures studies). Choices are normative – they are made from and for particular ideological positions, in relation to specific conditions, contexts and worldviews. However, as design scholar Luiza Prado (2014) argues concerning critical design, designers can be blind to the normative positions, ideological biases and political consequences of their work. Elaborating and multiplying possible futures is an exercise of power (Mazé, 2016), even if position or preference is not articulated or neutrality is claimed.

### Accounting for political dimensions of futurity in and through design

These relevant precedents in design theory and practice elucidate futurity as inherent and even intentional within design activity. While temporality and futurity have only entered substantially into design discourses relatively recently, such precedents, along with expanding alliances between design and futures studies, suggest a need to broaden and deepen design theory and practice from early spatial preoccupations to contemporary temporal concerns. Specifically, I argue that ideas about the future, or futurity, entail particular political dimensions to be further interrogated, and there are many possible approaches to better account for, study and do design. One approach along these lines is historical or genealogical, perhaps akin to literary studies like Fredric Jameson's *Archaeologies of the Future* (2005), such as critical design historical studies of 'the future' or critical analysis of futurity in design. Another approach is to articulate and develop common theoretical ground with the social and political sciences, for example as signaled in *Design Anthropological Futures* by Rachel Charlotte Smith et al. (2016 including Mazé, 2016).

A further approach is to articulate relevant knowledge, criticality and political dimensions from within design practice and on the basis of its own modes of operation (Mazé & Redström, 2009). For example, Karin Bradley, Ulrika Gunnarsson-Östling, Meike Schalk and Jenny Andreasson (2017) analyze Stockholm's *Vision 2030* through theories of feminist political ecology, but they also rewrite and redesign an alternative vision. This kind of approach entails criticality not only on the basis of theories from other disciplines but also from within design activity including its methods, materialities and modalities. Such practice-based approaches have a potential to articulate knowledge and politics not only as applied and reproduced in design but also as actively produced through design. From a design perspective, such an approach can thereby contribute to increased political reflexivity that is more profoundly and thoroughly integrated within the discipline. From a more general perspective, a design-based approach, as an "art of seeing and acting", may open for further and arguably important ways of knowing, experiencing and relating to futurity.

The remainder of this article dwells on this last approach, elaborating and reflecting upon a design-based example of which I have personal and in-depth knowledge. As a design researcher and practitioner, my own work over many years has developed in relation to concepts and genres of design outlined above. An example is the practice-based design research program 'Switch!' (Mazé, 2013a; Mazé & Redström, 2008), within which six experimental projects explored and developed approaches to changing perceptions, behaviors – and futures – of electricity consumption. One of these projects, 'Energy Futures', explicitly sought overlaps between futures studies and design methods and modalities, thus providing an opportunity here for me to further reflect on some of the political dimensions. In terms of "ontological politics" (Mol, 1999), for instance, we engaged in (re) producing, choosing between and multiplying different realities and futures of energy consumption. In retrospect, and recalling Inayatullah, I can query how this and other examples of design may "re-inscribe the power politics of the present instead of the openness or alternative possibilities of the future" (Inayatullah, 1990, p. 134). I can question the politics of what, or who, is present in the future, and which, or whose social norms, practices and structures are (re)produced or countered, and I can speculate on "What difference does it make?"

## Example: Switch! Energy Futures

Our objectives in the project ‘Switch! Energy Futures’ included generating scenarios/visions of future energy consumption and developing relevant design methods in relation to those within futures studies. Based on energy forecasts and social trends drawn from futures studies, Energy Futures revisits familiar urban and domestic artifacts in light of potentially emerging behaviors, beliefs and politics. Countering both the incremental reforms of user-centered design and the polarities of utopia/dystopia in critical design and visionary architecture (cf. Spiller, 2006), we set out to investigate the design of transitions between the familiar now and extreme futures. Resulting scenarios/visions from the project take the form of a series of redesigned artifacts that (fore)tell stories of transformed lifestyles and urban life. These were then mobilized in a public setting to host a debate with stakeholders about probable and preferred futures of electricity consumption. The project was developed by Aude Messenger, Thomas Thwaites, Başar Önal and myself, and an extended account is published elsewhere (Mazé, Messenger, Thwaites, & Önal, 2013).



Figure 1. A sampling from Energy Futures methods documentation

We attempted new combinations of futures methods such as environmental scanning, scenario building, role-play, fore- and backcasting with those more familiar in design, such as qualitative interviews, marketing segments and personas, visualization and prototyping, participatory workshops and exhibitions (Figure 1). This methodological mix supported us in moving beyond typical incremental approaches to sustainability, which often privilege the current needs of proximate stakeholders within near-future proposals. Our approach implicated familiar and everyday situations, participating stakeholders and existing contexts, but also explored larger-scale and longer-term dimensions. For example, enacting three different scenarios from the standpoints of the diverse personae (based on qualitative and marketing data), engaged power and (infra)structural dynamics, socio-economic and ideological distances, conflicts as well as similarities.



Figure 2. An overview of the artifacts generated within the Energy Futures superfiction

We then generated five ‘(super)fictive realities’ or ‘superfictions’ (Figure 2). These were articulated through collections of highly-considered and -crafted artifacts and media (e.g. “conceptual modelling”, see Seago & Dunne, 1999), including mock-ups and working prototypes, family-snapshot and journalistic photos, Wikipedia and YouTube media. Each superfiction was accompanied by a carefully-crafted narrative written in the first person as if from the future. Rather than one-liners (typical in concept and critical design), these blur between sci-fi and oral history, personal anecdote and reportage, to develop qualities that are nuanced and complex as well as strangely familiar, difficult and socio-psychologically conflicting as well as humorous.



*Figure 3.* Over the course of the public Energy Futures event, the contents of a closed case take over the space, unpacked, debated and arranged by participants as the superfictive narratives unfold

Energy Futures involved the staging of an exhibition that invited – and required – participation in interpreting and making sense of the strangely familiar and potentially difficult realities. Participants included invited designers, architects, educators, engineers and historians, who were asked to collaborate in unfolding and making sense of artifacts and narratives (Figure 3). Emerging along the way were a variety of intimate stories and personal opinions, as well as political issues and professional points of view. Participants thus articulated, deliberated and examined their individual and shared assumptions, discussed alternatives and declared their own position(s).

### **Reflecting on political dimensions through the example**

Within Energy Futures, we experimented with and reflected upon our methods, materialities and modes of working. The political resonances of these were not always immediately apparent nor easy to articulate, which is typical of tacit forms of knowledge within practice and of “criticism from within” design (Mazé & Redström, 2009). Through further reflecting on the project in relation to the political dimensions outlined above, I attempt to more explicitly articulate some of my experiences of our work relevant here.

Concerning the ontological politics of time, for example, we did assume a tripartite structure of past, present and future. As starting points within our process, we adopted existing energy scenarios (and assumptions) drawn from futures and economic studies. These appeared to be clearly placed and circumscribed within specific future times, though in more generic and macro-structural terms than typical in design scenarios. Thus, we began to further adapt and specify these with the help design methods to a more micro- and human-scale. In the process of doing this, we found temporal categories and scales to blur and shift. We found it problematic to precisely place scenarios within a timeline tool that we created for tracing a linear temporal trajectory from near- to far-future. In the end, no timescale was appended to the timeline. We made a decision not to order nor sequence the superfictions and, instead, to elaborate each on its own terms and in relation to one another.

Reflecting upon this difficulty, I can understand this in terms of political problematics of futurity. As we attempted to locate particular social phenomena on our timeline, we also recognized a continuum of precedents, reoccurrences and transformations, which somehow resisted placement in a single and definitive place and time. Even if we placed something somewhere specific, we saw how it may be also be placed elsewhere, and this was somehow important for us. By elaborating more specific scenarios in Energy Futures, perhaps because of a partly empirical basis (through personae and role-play), we came to recognize extremes as possible or probable and, even, as already existing in other parts of the world or at other times (cf. “multiple modernities” in Harding, 2008). Luiza Prado and Pedro Olivera (2015) point out that some critical designs may be everyday realities for some people(s), which may explain (though not excuse) why critical design resorts to extreme futures and dystopic stereotypes. We experienced the ambiguity and arbitrariness of dates and of distinctions between past, present and future, as well as the resistance of social phenomena to be pinned down within a timeline that seemed to presume an ability to generalize, sequence and quantify.

We also encountered issues relevant to the epistemological dilemma of knowledge about the future. In mixing methods, our knowledge basis for making decisions felt uneven and even insecure. Indeed, we were drawing from different disciplinary traditions, concepts and methods that are not commensurable in strictly scientific terms. Mixing qualitative, quantitative and practice-based design research as well as analytic, speculative and generative modalities, we were necessarily shifting between and across epistemological standpoints. Just as futures studies must operate on multiple and therefore disputable disciplinary grounds (Glenn & Gordon, 2003), arguably so must we in design. While a response to the dilemma could be to narrow or to improve methods, it would have been impossible for us to bridge all the epistemological gaps, particularly given evasiveness of some relevant phenomena to standard scientific methods. We had to come to terms with the fact that, for our purposes, replicable, robust and commensurable data was not the main point. If it had, we may have leaned toward available data and precedents, thereby potentially reproducing the ‘techno-centric’ paradigm of mainstream futures studies or the ‘technology push’ and ‘market drive’ of concept, critical and persuasive design. Instead, we sought to experiment methodologically and to construct what we felt were more holistic accounts at the scale of human experience, in which many phenomena could be presented in detail and in relation.

Within Energy Futures, our intention was to articulate multiple and competing visions of social life, to making explicit the differences and politics of alternatives. The superfictions evoked contrasts between and consequences of different paradigms in sustainable development discourse (cf. Mazé, 2016). For example, while the ‘Bionova Cord’ (Figure 2, labeled 15) evokes a technological silver bullet and win-win solution, a typically ‘eco-modernist’ trope in sustainability discourse, ‘Socket Bombs’ (Figure 2, 1-5) raise issues of eco-disobedience socio-spatial inequity. ‘Earth Day’ (Figure 2, 10-13) and ‘Power Forecast’ (Fig 2, 7-8) focus on potentially new cultural forms and communal solidarity, while ‘Blackout Zones’ (Figure 2, 14) suggests increased individuation, austerity and separatism. While the content of each superfiction varies, along with implied costs, benefits, exclusions and beneficiaries, each is carefully crafted from a first-person standpoint in order to humanize possible experiences of worldviews and realities that are very different.

One attribute of critical design was particularly important in this respect. Critical design adapts approaches from art, through which to establish some ‘critical distance’ from the market forces industrial status quo that circumscribe mainstream design practice. Learning from artistic methods and contexts of critical design, we departed from typically associated aesthetics, instead referencing pop culture and social media, though not for purposes of selling (as in concept design) nor convincing (as in persuasive design). In Energy Futures, we were interested in opening up, rather than resolving, determining or foreclosing particular futures. Each superfiction was carefully elaborated and self-contained but left a lot to the imagination. The superfictions did not directly

reference one another, yet they were crafted in juxtaposition in order to highlight contrasts and such that the whole might be greater than the sum of the parts. In developing and presenting the superfictions, our judgements were informed by qualities and criteria that are perhaps more artistic and literary than typical in either mainstream design or in science. The careful composition of the individual and the collection of superfictions, the low-brow aesthetics of the artifacts and a gallery context for the public event, cumulatively created a kind of ‘suspension of disbelief’ for more immersive, imaginative and critical engagement than typical for both design and research audiences.

In relation to stakeholders, we further departed from critical design, which can too often end in objects on display. Despite express intentions of “design for debate” (Dunne & Raby, 2009), material artifacts and spatial arrangements are typically more in focus than how these condition subsequent engagement, interaction and behavior (Mazé, 2007; Mazé & Redström, 2008). Exceptions that inspired us include the psychosocial side-effects of the Placebo artifacts by Dunne & Raby (2001) and a call from the US Pentagon to Ben Singleton (2009) and Jon Arden concerning their elitist and rather cynical ARK-INC. For us, Energy Future superfictions were not understood as ends in themselves but, rather, as a means to curate and stimulate reflection within and among stakeholders. Further, the aesthetics, contexts and audiences of critical design can be niche and elite (Prado & Olivera, 2015), potentially at odds with our intention to query normative modern and Western paradigms and to relate to other realities, norms and alternatives. While still a selected group, our invited stakeholders nonetheless engaged knowledges and represented professions outside the artworld and with a stake in alternatives. Thus, we drew on particular attributes and aesthetics of concept, critical and persuasive design, but carefully deployed these as a means to other ends involving stakeholders.

Through Energy Futures, we and stakeholders explored other ways of “seeing and acting” in relation to futurity. Through the process (with mixed methods) and through articulation (in aesthetic and narrative forms), we came to know, communicate, and learn further through the engagement with others concerning the politics of different sustainable development paradigms and the alternative worldviews, realities and choices indicated through the superfictions. In the process, our relation to ‘the future’ changed as we shifted away from treating it as a discrete temporal or as scientific subject to be studied, measured and determined through policy or design. Instead, futurity took on an important role as “an outside” (Mazé, 2016), a rhetorical, artistic or literary device to establish critical distance beyond a “preformed version of the real” (Grosz, 2001). Further, futurity as taking form in our designed superfictions sense took on an agency, a powerful material, narrative and curatorial basis for encountering, experiencing and exploring different realities of and with others, deliberation upon the “overarching politics of the real” (Inayatullah, 1990).

## Conclusion

Design, along with art and architecture, as Rajchman and Grosz argue, can provide essential modes of knowing, other forms of thinking, that are lacking in other disciplines – a perceptive “art of seeing and acting” (Rajchman, 1999) and a powerful “art of rhetoric” (Buchanan, 1989). Nevertheless, visions of the future – including those (re)produced by design – embody ideologies and, along with norms and priorities embodied and expressed, and shape policy planning, market economies and cultural imaginaries. Grosz also articulates this as “the supervalence of the future” (1999, p. 7), or the future as having agency and wielding power over the present. Such political questions are central to the field of futures studies, originally developed in the context of policy planning, which can be understood as engaging the future to inform, understand and/or control the present (Wangel, 2012).

Genres of design discussed here are only a fraction of those in which the future is at stake. While other genres may not relate to futurity as explicitly, designed communications, clothing,

products, environments and systems also shape our future(s). Unlike policy, design is always, literally, touching us. Design shapes our daily lives, beliefs and behaviors, (re)producing spatially- and temporally enduring forms of social life and society. Nevertheless, neither policy nor design will ever entirely determine social life nor colonize the future. These are continually deliberated and adopted or resisted by ordinary people all the time. This does not, however, lessen the urgency of expanding political reflexivity within design, including mainstream design for mass consumption and those genres explored here intended for “mass communication” (Dunne & Raby, 2009). Especially as design takes on roles of mediating deliberation, its political dimensions and determinism must become more explicit. This is crucial for designers, for those increasingly using design in futures studies and policy, and, not least, for stakeholders and publics subject to the powerful and political rhetoric of design.

The work elaborated here may be understood as part of a larger critical turn within, and at the intersection between, the disciplines of futures studies and design. Further possible, and, I argue, necessary approaches are also pointed out, such as historical or genealogical studies, and further overlaps and common ground with the social and political sciences. Design theory, practice-based design research and critical design practices increasingly contribute to critical accounts of design as an instrument of power, discipline and oppression (Mazé, 2007; Ericson & Mazé, 2011). Design can be understood as a profoundly political act, whether we are reflexive or intentional about this or not. We give form to what and how a particular reality (or future) may be confronted with others (Keshavarz & Mazé, 2013). As designers, we may not only put forward shallow claims of ‘solving problems’ or ‘making a difference’, or even important critical reflections on the question of “What difference does it make?”, we may use designed visions of the future to open up for thinking and doing otherwise, including handing over the question to others (as a political act).

It is no surprise that the field of futures studies includes more political reflexivity than design, given the long history of interrelations with policy, planning, participatory governance and deliberative democracy, as well as engagement with philosophical issues as elaborated above. While techno-centric, modern and gender- and Western-biased orientations still dominate futures studies, these are complemented and challenged by ‘prospective-action research’, ‘cultural-interpretive’ and ‘critical-postmodern’ approaches. With the general expansion of rhetoric and visions of the future today, many more could learn and would benefit from the political reflexivity developing within the field of futures studies. Perhaps more of us, as responsible professionals operating in disciplines overlapping with futures studies, should engage more profoundly, including philosophically and ethically.

## Acknowledgements

This article complements my chapter (Mazé, 2016) in the book edited by Smith et al. (2016). This research has been possible through the project ‘Utopia Now Here’, which was based at Konstfack University College of Arts, Crafts and sponsored by grants from Architecture in Effect, a strong research environment funded by the Swedish Research Council Formas at the School of Architecture of KTH Royal Institute of Technology, and from Konstfack’s Artistic Development Fund. Switch! was a design research program that I led at the Interactive Institute in 2008-10, funded primarily by the Swedish Energy Agency. Thank you to the Switch! Energy Futures team – Aude Messenger, Thomas Thwaites and Basar Önal. Credit for the artifacts, imagery and photography in Figures 1, 2 and 3 are due to the Switch! Energy Futures team, graphic layouts are by the designers Martin Frostner and Lisa Olausson of the Switch! book (Mazé, 2013a). I’m grateful to Josefin Wangel for enlightening and rewarding collaboration over several years.

## Correspondence

Ramia Mazé  
 Aalto University  
 Finland  
 E-mail: ramia.maze@aalto.fi

## References

- Adam, B. (Ed.). (2008). Future Matters: Futures known, created and minded. *Twenty-First Century Society: Journal of the Academy of Social Sciences*, 3(2), 111-116.
- Adam, B., & Groves, C. (2007). *Future matters: Action, knowledge, ethics*. Leiden, NL: Brill.
- Åhrén, U., Asplund, G., Gahn, W., Markelius, S., Paulsson, G., & Sundahl, E. ([1931] 2008). 'acceptera'. Reprinted in L. Creagh, H. Kåberg & B. Miller Lane (Eds.), *Modern Swedish Design* (pp. 140-347). New York: Museum of Modern Art.
- Baxter, A. (Ed.). (1996). *Vision of the Future*. Bliaricum, NL: V+K Publishing.
- Bohle, S. (Ed.). (2012) *Cause and Effect: Visualizing sustainability*. Berlin: Gestalten.
- Bradley, K., Gunnarsson-Östling, U., Schalk, M., & Andreasson, J. (2017). Futurist Feminist Political Ecology – Rewriting Stockholm’s Vision 2030. In M. Schalk, T. Kristiansson & R. Mazé (Eds.), *Feminist Futures of Spatial Practice* (pp. 301-328). Baunach, DE: Spurbuchverlag.
- Buchanan, R. (1989). Declaration by Design. In V. Margolin (Ed.), *Design Discourse* (pp. 91-109). Chicago, IL: University of Chicago Press.
- Candy, S. (2014). The Age of Imagination: A history of experiential futures 2006-2031. In Proceedings of the conference on Human Factors in Computing Systems CHI, Toronto, Canada.
- Dilnot, C. (2015). History, Design, Futures. In T. Fry, C. Dilnot, & S. Stewart, *Design and the Question of History* (pp. 131-243). London: Bloomsbury.
- Dunne, A., & Raby, F. (2001). *Design Noir*. Basel, CH: Birkhäuser and August Media.
- Dunne, A., & Raby, F. (2009). Interview. In Gary Huswit (Director), *Objectified* [documentary film].
- Ericson, M., & Mazé, R. (Eds.). (2011). *DESIGN ACT Socially and politically engaged design today*. Berlin: Sternberg Press / Iaspis.
- Fry, T. (2010). *Design as Politics*. New York: Bloomsbury.
- Gabrielli, S., & Zoels, J. C. (2003). Creating Imaginable Futures. In Proceedings of Designing User Experiences conference, New York, USA.
- Gidley, J., Fien, J., Smith, J. A., Thomsen, D., & Smith, T. (2009). Participatory Futures Methods. *Environmental Policy and Governance*, 19(6), 427-440.
- Glenn, J., & Gordon, T. (Eds.). (2003). *Futures Research Methodology* [2nd edition], Washington DC, US: AC/UNU Millennium.
- Grosz, E. (Ed.). (1999). *Becomings: Explorations in time, memory and futures*. Ithaca, US: Cornell University Press.
- Grosz, E. (2001). *Architecture from the Outside*. Cambridge, US: MIT Press.
- Gunnarsson-Östling, U. (2011). Gender in Futures: A study of gender and feminist papers published in Futures, 1969-2009. *Futures*, 43, 1029-1039.
- Höjer, M. (2010). Unpublished introductory remarks, Stockholm Futures Conference, KTH Royal Institute of Technology, Stockholm, Sweden.
- Harding, S. (2008). *Sciences from Below: Feminism, postcolonialities and modernities*. Chapel Hill, NC: Duke University Press.
- Ilstedt, S., & Wangel, J. (2013). Designing Sustainable Futures. In Proceedings of the Nordic Design Research Conference, Copenhagen, Denmark.

- Inayatullah, S. (1990). Deconstructing and Reconstructing the Future: Predictive, cultural and critical epistemologies. *Futures*, 22, 115-14.
- Irwin, T. (2015). Transition Design: A proposal for a new area of design practice, study, and research. *Design and Culture*, 7(2), 229-246.
- Jameson, F. (2005). *Archaeologies of the Future*. London: Verso.
- Keshavarz, M., & Mazé, R. (2013). Design and Dissensus: Framing and staging participation in design research. *Design Philosophy Papers*, 11(1), 7-30.
- Mattsson, H., & Wallenstein, S. O. (2010). *Swedish Modernism: Architecture, Consumption, and the Welfare State*. Black Dog Publishing.
- Mazé, R. (2007). *Occupying Time: Design, technology and the form of interaction*. Stockholm: Axl Books.
- Mazé, R. (Ed.). (2013a). *SWITCH! Design and everyday energy ecologies*. Stockholm: Interactive Institute Swedish ICT.
- Mazé, R. (2013b). Who is sustainable? Querying the politics of sustainable design practices. In R. Mazé, L. Olausson, M. Plöjel, J. Redström, & C. Zetterlund (Eds.), *Share This Book* (pp. 83-122). Stockholm: Axl Books.
- Mazé, R. (2016). Design and the Future: Temporal politics of “making a difference”. In R. C. Smith, K. T. Vangkilde, M. G. Kjaersgaard, T. Otto, J. Halse, & T. Binder (Eds.), *Design Anthropological Futures* (pp. 37-54). London: Bloomsbury.
- Mazé, R., Gregory, J., & Redström, J. (2011). Social Sustainability: A design research approach to sustainable development. In Proceedings of the IASDR Conference on Design Research, Delft, The Netherlands.
- Mazé, R., Messenger, A., Thwaites, T., & Önal, B. (2013). Energy Futures. In R. Mazé (Ed.), *SWITCH! Design and everyday energy ecologies* (pp. 6-44). Stockholm: Interactive Institute Swedish ICT.
- Mazé, R., & Redström, J. (2009). Difficult Forms: Critical practices of design and research. *Research Design Journal*, 1(1), 28-39.
- Mazé, R., & Redström, J. (2008). ‘Switch! Energy Ecologies in Everyday Life’, *International Journal of Design*, 2(3), 55-70.
- Mazé, R., & Wangel, J. (2017). Future (Im)Perfect: Exploring time, becoming and difference in design and futures studies. In M. Schalk, T. Kristiansson, & R. Mazé (Eds.), *Feminist Futures of Spatial Practice*, 273-286. Baunach, DE: Spurbuchverlag.
- Mazé, R., & Önal, B. (2010). Hands on the Future. In Proceedings of the Stockholm Futures Conference, KTH Royal Institute of Technology, Stockholm.
- Mol, A. (1999). Ontological Politics. In J. Law & J. Hassard (Eds.), *Actor Network Theory and After* (pp. 74-89). Oxford: Blackwell and the Sociological Review.
- Pipkin, L. (Ed.). (2016). *The Pursuit of Legible Policy*. Mexico City: Buró Buró Oficina de proyectos culturales.
- Prado, L. (2014). Privilege and Oppression: Towards a feminist speculative design. In Proceedings of the Design Research Society DRS Conference, Umeå, Sweden.
- Prado, L., & Olivera, P. (2015). Futuristic Gizmos, Conservative Ideals: On (Speculative) Anachronistic Design. *Modes of Criticism*, 59-66.
- Rajchman, J. (1999). Diagram and Diagnosis. In E. Grosz (Ed.), *Becomings: Explorations in time, memory and futures* (pp. 42-54). Ithaca: Cornell University Press.
- Reeves, S., Goulden, M., & Dingwall, R. (2016). The Future as a Design Problem. *Design Issues*, 32(3), 6-17.
- Rydell, R., & Schiavo, L. B. (Eds.). (2010). *Designing Tomorrow: America's world's fairs of the 1930s*. New Haven, CT: Yale University Press.
- Seago, A., & Dunne, A. (1999). New Methodologies in Art and Design Research: The object as dis-

- course. *Design Issues*, 15(2), 11-17.
- Simon, H. (1996). *The Sciences of the Artificial*. Boston: MIT Press.
- Singleton, B. (2009). DESIGN ACT Seminar 3 [presentation]. Retrieved 1 August, 2018, from <http://www.design-act.se>.
- Smith, R. C., Vangkilde, K. T., Kjaersgaard, M. G., Otto, T., Halse, J., & Binder, T. (Eds.). (2016). *Design Anthropological Futures*. London: Bloomsbury.
- Spiller, N. (2006). *Visionary Architecture: Blueprints of the modern imagination*. London: Thames & Hudson.
- Stockholm Futures Conference (2010) KTH Royal Institute of Technology, Stockholm. Retrieved 1 August, 2018, from <https://www.cesc.kth.se/news/news-archive/stockholm-futures-conference-1.403327>
- Svenfelt, Å. (2010). *Two Strategies for Dealing with Uncertainty in Social-Ecological Systems* (Doctoral dissertation, KTH Royal Institute of Technology, Sweden).
- Verbeek, P. P., & Slob, A. (Eds.). (2006). *User Behavior and Technology Development*. Berlin: Springer, 2006.
- Vergragt, P. (2010). Sustainability Future Visions: Impacts and new strategies. In Proceedings of the LeNS Conference, Bangalore, India.
- Vergragt, P. (2012). Unpublished interview by R. Mazé, Tellus Institute, Boston, Dec 5.
- Wakeford, N. (2014). Unpublished opponent comments to the Doctoral dissertation of Kristina Lindström and Åsa Ståhl, Malmö University, Sweden.
- Wangel, J. (2012). *Making Futures: On targets, measures and governance in backcasting and planning* (Doctoral dissertation), KTH Royal Institute of Technology, Sweden. Retrieved from <http://urn.kb.se/resolve?urn=urn:nbn:se:kth:diva-94151>.
- Wangel, J. (2011). Exploring Social Structures and Agency in Backcasting Studies for Sustainable Development. *Technological Forecasting and Social Change*, 78(5), 872-882.
- Winner, L. (1995). Political Ergonomics. In R. Buchanan & V. Margolin (Eds.), *Discovering Design* (pp. 146-170). Chicago: University of Chicago Press.



# Crafting Spaces Between Design and Futures: The Case of the Agboglobshie Makerspace Platform

**Cher Potter**  
University of the Arts London  
Victoria and Albert Museum  
UK

**DK Osseo-Asare**  
Pennsylvania State University  
USA

**Mugendi K. M'Rithaa**  
Independent Designer-Researcher  
Kenya

---

## Abstract

*Written as a design studies inquiry, this article employs a futures studies technique – namely causal layered analysis (CLA) – to further examine a design practice case study. CLA is used as a lens through which to analyse the ideologies and worldviews embodied in the “design future” postulated by the Agboglobshie Makerspace Platform in Accra, Ghana. Preliminary ideas regarding a fuller exchange between the disciplines of futures studies and design studies are suggested.*

**Keywords:** Design, Futures, Causal Layered Analysis, Agboglobshie, Systems Design, Co-Design, Afrofuturism, Afrikology, Afridesignx.

---

## Introduction

In 2015, a network<sup>1</sup> of designers, technological innovators and material culture scholars from the cities of Dakar (Senegal), Accra (Ghana), Nairobi (Kenya), Cape Town (South Africa) and London (UK) known as AfriDesignX was established to investigate “Design futures in Sub-Saharan Africa” (Leverhulme Trust Annual Review, 2015, p. 50). This ongoing network addresses an urgent need to better understand how a so-called digital revolution, combined with unprecedented city and population growth on the African continent

is resulting in new typologies of design<sup>2</sup>. Design projects in each of the above-mentioned cities have been studied in terms of their response to local challenges, their application of vernacular design concepts and their implications for the future of crafts and production in particular regions on the African continent. However, the nature of the various design futures embodied by these designs has not been critically examined. With reference to the *Agbogbloshie Makerspace Platform* (AMP)<sup>3</sup> initiated by architects DK Osseo-Asare and Dr Yasmine Abbas, this paper employs Sohail Inayatullah's Causal Layered Analysis (CLA) as a framework for analysis to unpack stories about the future that this particular design project supports.

Before describing the project, it is necessary to understand the nature of the site in which it operates – Agbogbloshie. Popularly maligned as “Sodom and Gomorrah” by non-residents, Agbogbloshie is a 20-acre scrapyards in the city of Accra, Ghana adjacent to the Old Fadama slum community. Here, over 7000 people work in poorly-equipped and poorly-constructed workshops (Figure 1), dismantling discarded automobiles, microwave ovens, old consumer electronics and more into component parts to be resold or re-used. While it could be argued that the economic activities of the district offer a constructive alternative to the take-make-dispose extractive industrial model, they are also responsible for the production of very high levels of health-threatening pollutants. As part of the recycling of particular substances such as rubber insulation and car tyres, high levels of carbon dioxin, carbon monoxide and other pollutants are emitted (Figure 2), effecting the health of both Agbogbloshie workers and residents of the surrounding areas (Minter, 2016). Jobs within this district are therefore considered part of a troublesome and unmanageable informal sector and these unregistered enterprises remain unsupported and unregulated by the state.

To assist Agbogbloshie workers in transforming this district into a safe and semi-professionalised economic area, based on the principles of the circular economy, Osseo-Asare and Abbas aim to refine existing practices of the workers through design. It is important to note that AMP is not a neat and concise design project, with perfectly finished products and a clear statement of intent. Rather, it is ongoing research-based design activity embedded within a particular community, exploring alternative futures around design production and knowledge sharing within and around this locality. On a practical level, this involves the architectural planning and construction of solar-powered on-site workshops (Figure 3), skills training regarding the use of machines, establishing new processes for controlling hazardous substances and an information-sharing platform that helps workers distribute materials and working methods. On a conceptual level, it involves mapping out an alternative production and health futures for the district at large, in collaboration with workers and residents.



Figures 1 and 2. DK Osseo-Asare and Yasmine Abbas, Agboglobshie site - fieldwork documentation, 2014

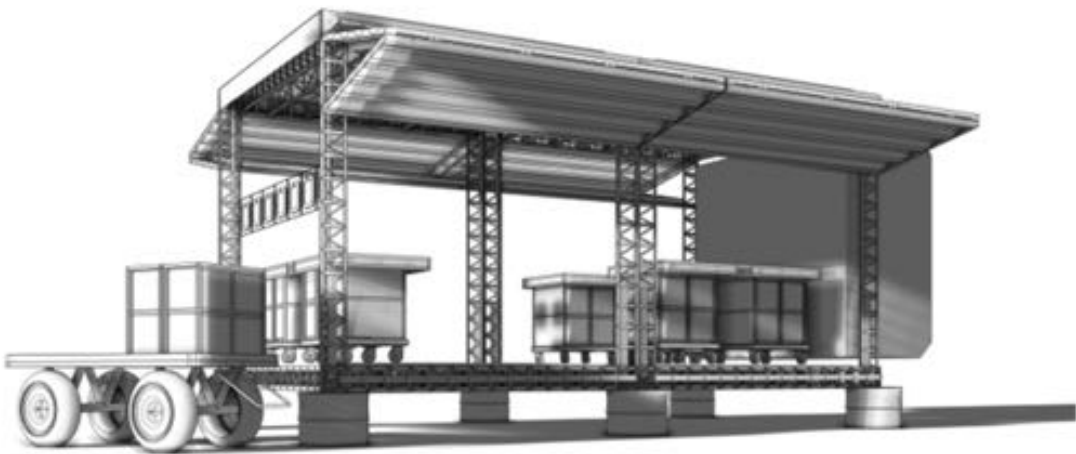

Figure 3. DK Osseo-Asare and Yasmine Abbas, Agboglobshie makerspace/workshop design, 2014

In its application of CLA to this particular case study, the paper aims to:

1. Offer designers and design theorists a methodology for disclosing and organising the narrative framing of their work, particularly with reference to stories about the future.
2. Offer futures studies scholars a way to interpret the design principles and constraints, construction, craft and functionality of built artefacts as integral to any design future scenario;

### **Delineating Design Futures in Relation to the Case Study**

The term “design futures” as used within the above-titled AfriDesignX research network has purposefully remained open for interpretation. However, for the purposes of this paper, the term deserves further delineation in the context of design and futures studies.

Design in its modern and Western formulation, with its inception tied closely to the advent of 19<sup>th</sup> Century industrialism, is often considered hand-in-hand with economic growth and industrial advancements that look towards a better future. As a contemporary and critical counterpoint to this logic, a set of practices referred to as “critical design”, “speculative design”, “design fiction” and various other nomenclatures have emerged over the past decade. While each sub-discipline varies somewhat in its motivations, as a general connecting principle these practices challenge industrial assumptions and operate outside of commercial concerns. They attempt to do more than make products more beautiful or processes more efficient. According to Tony Dunne and Fiona Raby, pioneers of the approach, practitioners who choose this pathway make artefacts that are designed to pose problems and ask us to imagine the future in a very different way (Dunne & Raby, 2013).

Designers Stephanie and Bruce Tharp offer the umbrella term “discursive design” to describe these interrelated practices whose products function primarily to “raise awareness and perhaps understanding of substantive and often debatable issues” (Tharp & Tharp, 2013, p. 407). This latter approach to design lends itself to application within the field of futures studies, where future scenarios are developed in order to enlighten and raise debate on the possibilities we face as individuals, organizations, nations or worlds. Stuart Candy and Jake Dunagan’s “experiential futures” (XF) model emerges out of the field of futures studies and aims to manifest and embody designated future scenarios through the use of physical media. According to Candy, XF involves “the design of situations and stuff from the future to catalyze insight and change” (Candy, 2018, p. 235). It may be argued, that to an even greater extent than is the case in discursive design practice, the craft, functionality, scalability and problem-solving aspects of the design artefacts themselves are secondary to the possible worlds the objects represent. Dunagan re-iterates this idea in his contribution to this particular special issue:

*An important point that can be lost ... is that the artefacts and the experience is not the work. The actual work and rationale for the method is that it will lead to better futures thinking, better decision-making and strategy, and ultimately, more preferred futures. (Dunagan, 2018).*

While not commonly used for futures studies purposes, Bruce Sterling’s diagram of *Anticonventional Objects* (Sterling, 2013) may help to characterize the unconventional design space that both experiential futurists and discursive designers are interested in with regards to their pursuit to expand our thinking around future possibilities. The diagram (Figure 4) shows conventional objects at the intersection of what is desirable, buildable and profitable, while anticonventional objects operate on the outer periphery of these commercial design standards. The latter are associated with ideas of the speculative, the illicit, the discarded, the magical – they are objects of possibility rather than probability. This shift in design from “What’s the problem?” to “What’s possible?” was also the maxim for Kenyan-born designer Mugendi M’Rithaa during his presidency of the World Design Organization (2015 – 2017). As a spokesman for industrial design, he promotes a move away from consumer demands towards the utilization of “design as a catalyst for positive change” (M’Rithaa, 2018).

However, for M’Rithaa, functionality and scalability remain key design principles within majority world contexts (or [industrially] developing economies) and their respective communities. He actively rejects the above distinction between problem-solving and broad-based speculation – a sentiment mirrored by Alioune Sall, Director of the African Futures Institute. “The future does not come by itself but has to be met and the conditions for its hatching have to be created” (Sall, 2003, p. 11). These conditions Sall refers to are the capacity to imaginatively explore long-term African futures without “submitting to the dictatorship of urgencies and [...] hardships” (ibid.), alongside a deep consideration for how society is organized, how it produces and how it functions.

As we shall learn in the analysis that follows, the present case study troubles the binary suggested by the *Anticonventional Objects* diagram which assumes a separation between speculative and industrial or commercial praxis. Rather, it implies a “both and” approach that invites us to explore the intersections of functionality and discursive provocation in a real-world project. Thus, design futures in the context of this particular case study does not align to particular sub-divisions in design practice, but rather aims to encapsulate aspects of each.

## Causal Layered Analysis Applied to Design Practice

The use of Causal layered analysis within futures studies is “not in predicting the future, but in creating transformative spaces for the creation of alternative futures” (Inayatullah, 1998, p. 815). The rationale behind this approach is that any future scenario developed by an individual or institution is underpinned by conscious and unconscious assumptions about the way the world works (or should work). Inayatullah argues that these assumptions need to be brought to light in order to fully understand the nature and implications of the future realities being proposed.

CLA offers an appropriate framework for the project in that it offers potential to illuminate the polyvalent situatedness of design production — as a process which simultaneously engages a bounded set of spaces, stakeholders and scenarios together with and in opposition to an open-ended terrain of alternate realities across space-time. The distinctive layered approach of the CLA technique when applied to a design artefact or system offers a neat structuring device through which it reveals to the reader the complex relationship between litany, systems, design response, discourse/worldview and communal myth/metaphor. The approach involves analysis across four levels<sup>4</sup>:

1. *Litany* – popular, media-driven understandings of an issue;
2. *System* – critical understandings of the issue generated by academic research relating to social, structural and systemic realities;
3. *Worldview* – civilizational assumptions that underpin the issue; and
4. *Myth / metaphor* – archetypes, mythologies and proverbial truths that lend meaning to the issue.

The paragraphs that follow employ these four layers of analysis as a way to interpret the case study and the stories it tells about possible futures.

### Litany

In 2014, Agbogbloshie was described by media outlets from the Guardian to Al Jazeera as the “world’s largest e-waste dump” (Guardian, 27 February 2014; Aljazeera, 1 January 2014), a “hellscape” (Wired, 23 April 2015) where the developed world’s discarded electronic and electrical devices “go to die” (Wired, 23 April 2015). This litany has been perpetuated by images which circulated online news sites such as New York Times under the heading “A Global Graveyard for Dead Computers in Ghana” (nytimes.com, 4 August 2010) or Dazed Digital under the title “Digital Wasteland” (dazeddigital.com, unknown.), portraying young men in an extreme environment burning cables and wires to collect copper. In October 2018, a Google internet search of Agbogbloshie<sup>5</sup> revealed top ranked news stories that included an article on the untapped potential of African landfills (United Nations News and Stories, 24 September 2018) and on Agbogbloshie as an “urban mine” around which design innovation is being generated (Penn State News, 21 September 2018).

Given the mediation of the site in 2014, a typical reading of the issue may have delimited the problem in rather a narrow sense, triangulating e-waste, environmental pollution and disenfranchised African people burning old electronics in a toxic/exotic (foreign) landscape. The subsequent

changed narrative is in part due to recent academic and UN-sponsored research<sup>6</sup> that has challenged exaggerated news media and shown the problem of electronics importation to be far more complex than headlines depict, with much of the waste generated within the region itself. Another factor that has impacted the narrative is Osseo-Asare and Abbas' design initiative the *Agbogbloshie Maker-space Platform* (AMP) begun in 2012. These designers argue publicly that to view Agbogbloshie as a dumpsite is a failure to recognise the extensive and elaborate systems of manufacture operating in and around the site - systems that entail "maker" communities engaged in recycling, repairing, reconstituting and inventing products using discarded components (Figures 5 to 7).

Ironically, despite Osseo-Asare and Abbas' vehement rejection of the hellscape narrative around Agbogbloshie, it was precisely this kind of narrative that has fuelled public interest in AMP.

*The images of young Africans crudely burning the innards of old electronics to make a few bucks was so shocking to people in the West, and so burnt into the global imaginary, that the counter-narrative – that young people in and around these same spaces can be and already are makers – surprised people. When this more hopeful message was obliquely linked to ideas of social entrepreneurship, it became even more appealing to international audiences (Osseo-Asare, personal communication, 2019).*

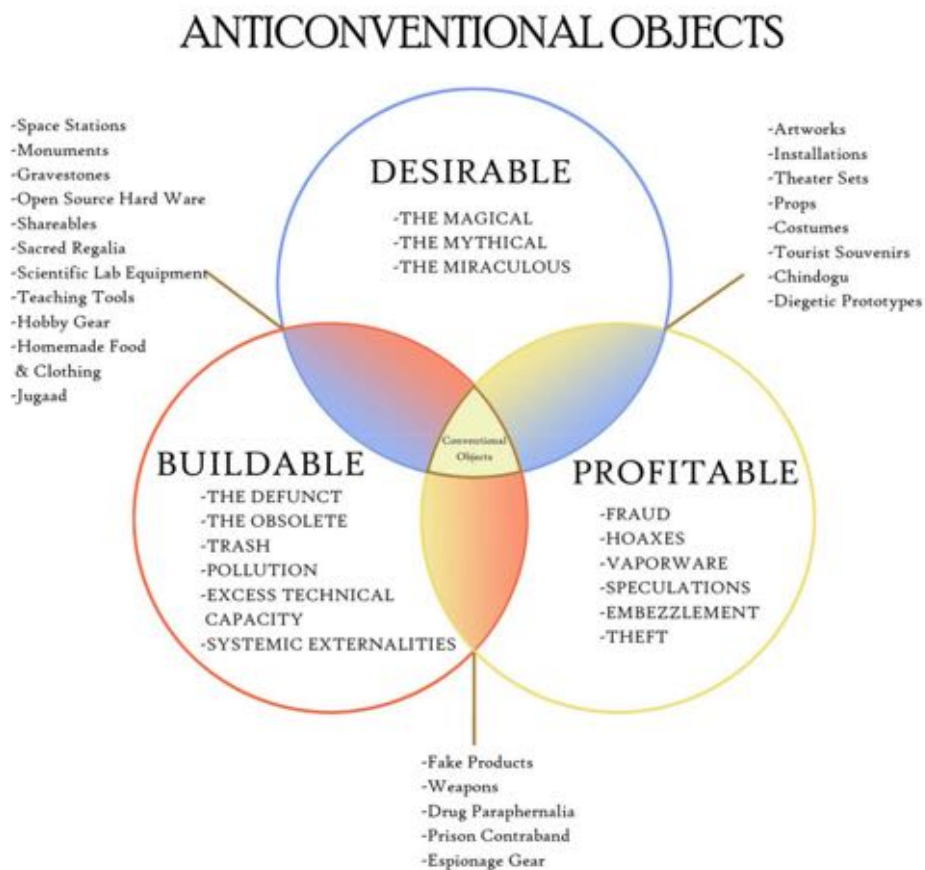

Figure 4. Bruce Sterling, Anticonventional Objects diagram, 2013



Figures 5 to 7. DK Osseo-Asare and Yasmine Abbas, scrap organisation and metal smelting activities - field-work documentation, 2014

## System

In situating Agbogbloshie within broader systems, we encounter problematics related to economic, environmental and socio-cultural factors. Firstly, misunderstanding around informal production and commercial sectors have resulted in the existing ecosystem of recycling, repair and manufacture receiving little governmental support. Secondly, environmental factors related to hazardous wastes and their handling and disposal have not been adequately communicated to Agbogbloshie workers. Finally, in order for Agbogbloshie workers to better thrive in their professions, technical know-how and recognised standards of practice need to be addressed.

For Osseo-Asare and Abbas, the design response called for methodological approaches that prioritise user-oriented systems modelling (systems design), participation among different interest groups (co-design) and methods that ensure safety and product/system/process repeatability (engineering skills and standards).

## Systems architecture

Osseo-Asare notes that despite various government efforts to sanitise and restore the area, the perspectives of the recyclers, makers and inhabitants based at the site have rarely been taken into account with regards to envisioning Agbogbloshie's future (Covertruth.com, 3 April 2017). In fact, government restoration efforts have been largely disputed by local inhabitants who would be required to leave the area in order for these plans to be implemented (Safo, 2002). In order to better understand the production and commercial system at Agbogbloshie and the lives of the community inhabitants, Abbas and Osseo-Asare conducted interviews with approximately 700 individuals - roughly 10% of people working in the site. Interviewees included amongst others plastics recyclers, copper extractors, metal workers, computer repairers and refurbishers. In accordance with Mark Maier in *The Art of Systems Architecting* (2010), the focus of these interviews was to better understand the activities and ambitions of the people who live and work on the site. "A systems approach is one that focuses on the system as a whole, specifically linking what is desired with what is feasible.... grounded in the user's purpose." (Rechtin & Maier, 2010, p. 8).

*From this, we were able to recognise that making is a spectrum, which goes from unmaking and remaking to making anew. We worked with makers to spatially map the work areas to understand where different activities happen - where workshops are located, where disassembly takes place, where scrap is stored... We collected data (Figure 8) about the waste stream and modelled these flows all the way from the import of products, their reuse, their recycling and ultimately to their export (Osseo-Asare, personal communication, 2018).*

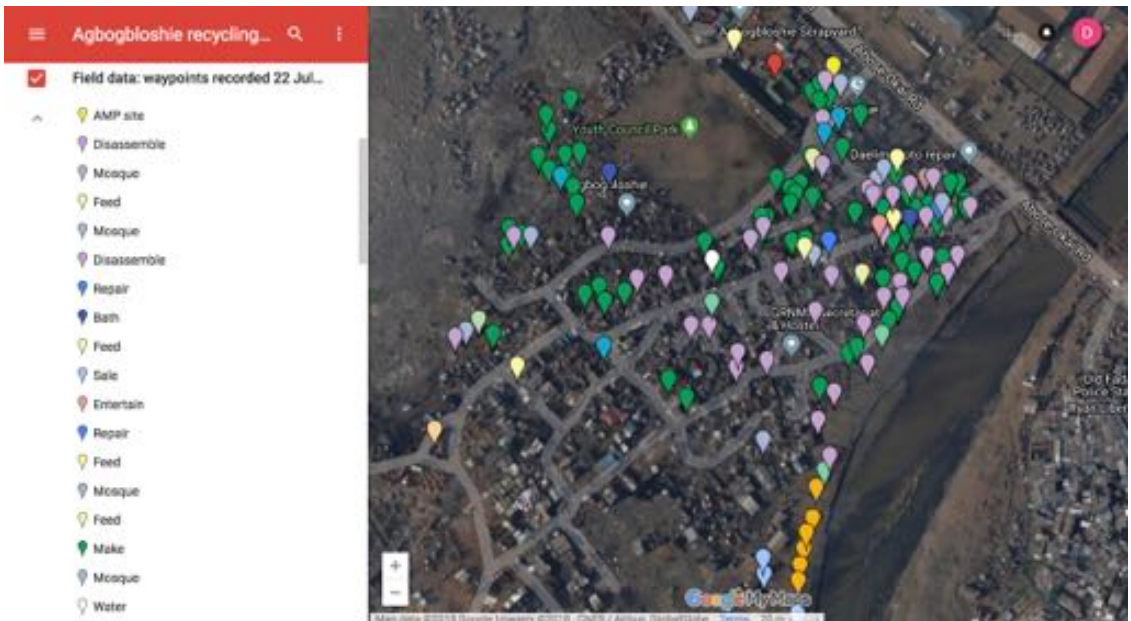

Figure 8. DK Osseo-Asare and Yasmine Abbas, Agbogbloshie recycling and maker ecosystem - fieldwork documentation, 2014

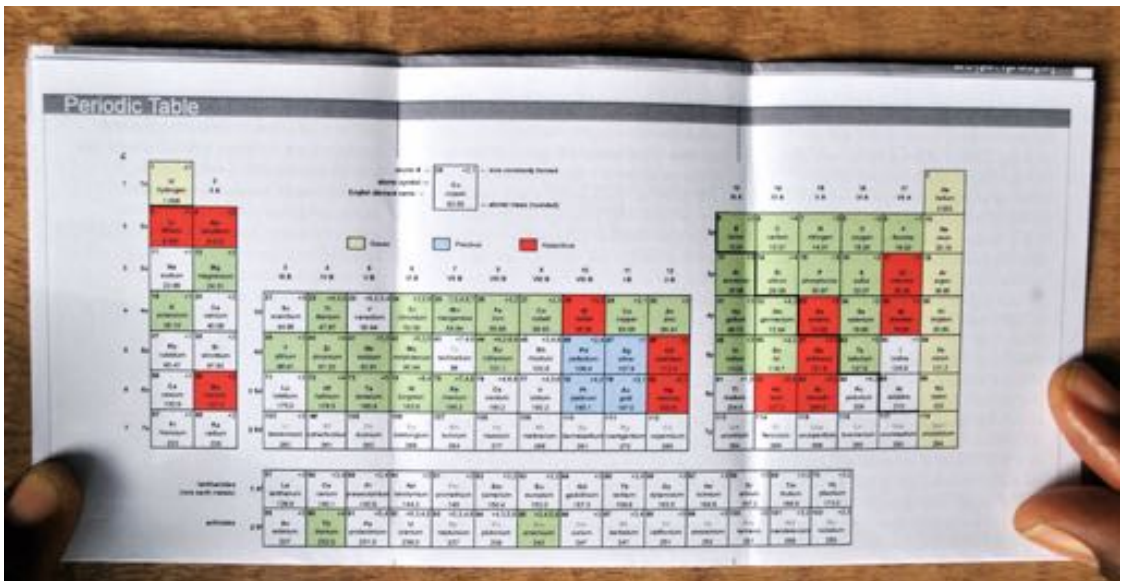

Figure 9. Ivy Asuo, Agbogbloshie distribution of materials in 3E stream, 2014

### Co-design workshops

Following these interviews, the “AMP Makers Collective” was established with participation to date of over 750 grassroots makers and scrap dealers from Agbogbloshie and Accra’s informal sector, alongside more than 750 students, recent graduates, young professionals and researchers working across STEAM fields of science, technology, engineering, arts and mathematics. Members

of this collective conducted a series of workshops with community leaders, public health experts and environmental experts in order to better understand the nature of the materials being handled (Figure 9) and the environmental hazards they produced. This transdisciplinary and participatory approach to design-led research is based on the understanding that “changes in the socio-technical systems of complex organisations are driven by co-design processes in which citizens and designers play a meaningful role” (Manzini & Rizzo, 2011, p. 199). Here, the designer adopts “the role of mediator (among different interests) and facilitator (of other participants’ ideas and initiatives) but involves more competences ... in terms of creativity and design knowledge” (Manzini, p. 200). These competencies include the ability to select from distinct design approaches and to conceive and realize artefacts that manifest participants’ views.

In this case, the research findings were translated into plans for three design components that function together as AMP. These components are designed to assist grassroots makers to gather the resources and tools that they need for their specific area of production, to learn through shared practice and to produce better quality items in larger quantities. Firstly, a makerspace kiosk - this is a modular construction system that is mobile and expandable, featuring two prefabricated light-gauge steel semi-octet truss frames with bi-fold hangar doors installed on recycled tire foundation pads (Figures 10 to 11). The structure can be assembled, disassembled and reassembled in situ and as needed. This micro-architecture is designed to be constructed using tools and material readily available at the site and can be plugged into pre-existing spaces of manufacture. Secondly, maker toolkits – these are customizable for a given community’s requirements, to support what makers want to make. Finally, a mobile app for Android, that amplifies makers’ capacity for making and trading through information-sharing. The app is designed to establish a digital network linking recycling with digital fabrication and distributed manufacturing, as well as providing people with a better understanding of the hazards of certain materials.

### **Engineering skills and standards**

The initial stage of prototyping involved finding the appropriate materials at Agboglobshie and building the tooling, jigs, rigs, templates and fixtures that enabled people working in the site to make the prefabricated steel truss elements of the kiosk within their existing work spaces (Figure 12). A set of toolkits or standards were established following workshops in bench skills, metal and machine processes, fabrication and thermal joining techniques. The construction of the kiosk itself was tested under the constraint that it should ultimately require two people and four hours to assemble or disassemble a single module by hand.

*The toolkits went through many iterations in order to rethink and understand how people were making things – and how some of these processes could be improved and retooled. It is important to understand that young men working in these kinds of informal grassroots spaces, are learning largely through apprenticeship. They learn in a heuristic way - by doing, by making actual things - which can be radically different from how textbooks of engineering or architecture describe processes of construction (Osseo-Asare, 2018).*

The structural frame includes allowances for solar-powered electricity generation, water collection and water filtration; a prefab floor structure; and a hydroponic wall system. The internal toolkits, which are still in the process of being researched and developed involve work benches and a ceiling-mounted CNC robot (Figure 13). The self-contained, mobile and modular nature of the structure borrows design principles from both robotic spacecraft and human space stations. This led to the designers referring to the kiosks as “spacecraft”. However, the concept of “spacecrafting” has subsequently been developed - Abbas and Osseo-Asare now employ the concept of spacecrafting to refer to a knowledge regarding how to craft what you want or need out of your space (environment).

The notion of crafting - that is the activity of making well by hand - becomes in this context, “a place where space is crafted across physical, virtual, augmented and digital realities” (<https://qamp.net/spacecraft/>).



Figures 10 to 12. Agbogbloshie Makerspace Platform in situ construction, 2014



Figure 13. AMP CNC tooling prototype, 2014

## The Discourse And Worldview

In order to envision alternative futures, CLA offers a way in which to investigate how the discourses we use to understand the idea may be complicit in our framing of the issue (Inayatullah, 2004, p. 17).

### Afrofuturism

Given the project’s focus on African innovation and its overt references to interstellar exploration, it has been described within the design world as operating within the Afrofuturist cultural tradition (Dezeen, 16 May 2016). This characterization is challenged by its designers who point out that Afrofuturism—as first introduced by Mark Dery in his classic text “Black to the Future: Afro-Futurism 1.0” — is originally an emergent approach pioneered in the USA by artists such as the sci-fi novelist Ralph Ellison and the jazz musician Sun Ra. It offers an enabling

environment for African-Americans to liberate themselves from Euro-American control of time and space, and thus overlaps with American notions of Afrocentrism. Complexifying this re-presentation of a diasporan future of the African continent that is philosophically and technologically transcendent, Kodwo Eshun points out in his essay “Further Considerations of Afrofuturism” that Afrofuturism is an activist approach that offers counter or alternative future scenarios that centralize Africans as a way to reorient attitudes towards Africa in the present (Eshun, 2003).

Contentiously, the South African media artist Tegan Bristow distances the Afrofuturist approach from any direct African territorialisation, writing that “Afrofuturism has nothing to do with Africa, and everything to do with cyber culture in the West” (Bristow, 2012, p. 25). To some extent, this stance is supported by Osseo-Asare and Abbas who take issue with Afrofuturism representing a glossy techno-aesthetic of pure fiction where the allure of exciting futuristic visions out of Africa coincide with non-functioning technologies that can never be real(ized) in Africa. They contend that both African and non-African actors actively adopt and seek to reinvent Afrofuturism - as a tactic to acquire resource, exposure and opportunity, on one hand, and as a strategy of wealth creation through mass commercialization, on the other hand - as something African-generated.

*International audiences embrace Afrofuturist visions like those portrayed in Black Panther that take place in fictional countries such as Wakanda. However, when these African futures are depicted as being part of global geopolitical realities and every day existences, they are often less compelling (Osseo-Asare, personal communication, 2018).*

The primary concern for Osseo-Asare and Abbas is not whether Afrofuturism centralizes Africans or decentralizes global narratives, but rather how to instrumentalize it as a practice of equitable future-making. Afrofuturist and futures studies scholar Dr Lonny Brookes<sup>7</sup> goes some way to address this disconnect between fictional futures and real-world experience in his concept of “futuretypes”. The term is a play on the concept of prototypes and refers to the emergent samples or early models of futures that can be identified within a given community. To capture futuretypes, he suggests using ethnographic research to map the everyday routines, daily movements, embodied experience and future imaginings of a group of people and use these as a basis for speculating what forms of digital design might be most useful to this particular group (Brookes, 2017). While Brookes’ research operates within diasporic communities in the USA, it is applicable here in that he collapses fiction and reality, not only to be psychologically emancipatory, but also to inform design practice and R&D of real technology.

### **Maker-oriented futures**

The title of the project as assigned by Osseo-Asare and Abbas implies a conscious framing of the *Agbogbloshie Makerspace Platform* in terms of 21<sup>st</sup> Century maker culture. The proposition of this global cultural movement as espoused by Science fiction writer and technology activist Cory Doctorow in his book *Makers* (2010) is as follows: Technology enables makers to network like never before and provides the tools – cognitive, social and physical – that allows them to share ideas to improve and build on their inventions. In accordance with this, AMP aims to fuse digital and physical processes of production offering both a digital platform that enables information-sharing between Agbogbloshie makers and those further afield, as well as an open construction system that serves as an architecture for hosting physical spaces of making within Agbogbloshie. We might relate this to the “Mixed Responses” approach<sup>8</sup> suggested by DfD (design for development) educator James Fathers (2004) who emphasises the centrality of information technology and industrialisation to any design project aimed at improving well-being.

The maker movement’s fundamental assumptions of sharing and equity are challenged by science educators Angela Barton and Edna Tan. They point out that the main pillars that underpin

maker culture - making as a set of activities, makerspaces or *fab labs* as communities of practice, and makers as identities – have a white, middle-class bias (Barton & Tan, 2015). They impel us to ask: who is able to call themselves a maker and what activities constitute making – that is, who are the assumed members of this particular culture club? In this regard, Osseo-Asare insists, “practices such as [those] at the Agbogbloshie site have always been in the realm of making, hacking and repair, even before the so-called ‘maker movement’ was established... To frame the maker culture as foreign in the Agbogbloshie context is highly problematic and exacerbates the belief that solutions come from outside of Africa. There are already makerspaces in Ghana... let’s see them as makerspaces and bring them into the discourse.” AMP then, instrumentalizes maker-ism in order to operate as part of an international network, but simultaneously positions Agbogbloshie makers as pre-emptive to the movement itself.

If AMP originates with the understanding that Africans are already makers, there is a tension that underpins this notion. On the one hand, technology scholars such as Ron Eglash point out that “Fixer practices are quite prevalent on the African continent due to economic necessity: the expense of new devices, the paucity of products or replacement parts, and the need for means of employment” (Eglash & Foster, 2014, p. 128). Waldman-Brown, Obeng, Adu-Gyamfi, Langevin, and Adam in the paper “Fabbing for Africa’s Informal Sector” (2014) opens with the statement “To manufacture anything in Sub-Saharan Africa (SSA) requires the same creative maker sensibility that is valued throughout the fab lab community” (Waldman-Brown et al., 2014, p. 1). On the other hand, it is important to note that the AMP spacecraft aims to upgrade makers’ capabilities to produce designs of quality through workspaces, technologies and skillsets associated with maker culture. The authors of this paper alongside the designers of AMP argue that despite a global media celebration of Africa’s necessity-driven ad hoc hacked innovation, maker capacity on the African continent is constrained rather than facilitated by a focus on makeshift solutions and *ultra*-low-cost delivery.

An aspect of maker culture that AMP actively aligns itself with is the notion of informality. AMP’s distributed informal solutions stands in opposition to a top-down model currently being proposed for Agbogbloshie, which is based around a large centralized factory supported by a German development agency GIZ. This mechanised “formal” solution seeks to monetize e-scrap as a large-scale profit-making operation that consolidates wealth for the benefit of owners and shareholders, done in concert with government policy. While this proposal promises improved health and working conditions, it assumes control of production and circulation within Agbogbloshie (Giz.de, 2016). Informality is, as in the case of hacker culture, of which global maker culture is an offshoot or allied force, a defiant insistence that human beings should retain the right to remake the world themselves, without externalized systems of control.

### **Afrikological futures**

The AMP represents an engagement with indigenous R&D and a commitment to the idea that problems on the African continent are better tackled using transdisciplinary, co-design methods that prioritise local stakeholders and African design solutions. In his book *Afrikology and Transdisciplinarity: A Restorative Epistemology* (2011), the Ugandan development specialist Dani Wadada Nabudere offers an epistemology of restorative rights on the African continent anchored in a strategy of transdisciplinary African problem-solving.

When viewed in the context of design aimed at improving human well-being and meeting basic needs, the philosophy seems to call for a three-pronged approach: (a) a research strategy that crosses many disciplinary boundaries and community perspectives; (b) the development of design responses that reposition African culture and collectivism as a key tool in solving current social challenges and (c) an acknowledgement that the academic world has been built on a Western premise that has mapped the world into categories of first, second and third; and an active rejection of this.

Nabudere advocates “doing justice to communities’ capabilities to reflect and act without losing sight of the structural circumstances that enable and at times constrain them. It is about people’s strength” (Wanda, 2013, p. 23). This alignment with capability and strength rather than need marks a notable departure from the lexicon of well-meaning 20<sup>th</sup> Century “Design for Need” movements, which emphasise the designer as “a ‘seed project’ helping to form a corps of able designers out of the indigenous population of a country... firmly committed to their own cultural heritage...and their own needs” (Papanek & Fuller, 1972, p. 95).

AMP then, aims to put forward an Afrikological, maker-oriented futures model rather than an Afrofuturist one, prioritising African-produced futures that enhance existing community capabilities. The proposed “production future” manifested in AMP is less about bringing Makerbots and Arduinos into use and more about supporting the long-standing fixing and making traditions already established in Ghana. Blacksmithing and pot-fabrication collectives, wire recyclers, television repairers and others within Agbobbloshie intersect with international developments in innovation to challenge both local and international top-down socio-political solutions. In challenging discourses around African futures, Osseo-Asare and Abbas present spacecraft that function not as interstellar modules, but as terrestrial workshops made from local and international upcycled e-waste that support design research with grassroots makers to produce consumer goods.

## Myth / Metaphor

The design problem being addressed in AMP is two-fold and interdependent: (a) Agbobbloshie is both misrepresented and misunderstood as a dysfunctional and uninhabitable site outside of its local community and as such (b) makers that operate within Agbobbloshie are marginalised and lack the support to further develop their skills, tools and trades so as to amplify their reputation as makers. While the latter is addressed through a combination of in-situ design processes; the latter involves outward-facing storytelling tactics for international audiences of the project. In response to the media representations of Agbobbloshie as a hellscape, graveyard or wasteland, Osseo-Asare and Abbas consciously borrow craft and scientific metaphors associated with globally-recognised maker culture and space exploration to describe the project. In doing so, their project “combine(s) instrumental functions for the user, with communication to audiences” (Borland, 2011, p. 1).

According to the project website [qamp.net](http://qamp.net):

*AMP spacecraft is an alternative architecture ‘for making’.*

*Small-scale, mobile, incremental, low-cost and open-source, spacecraft operate as a set of tools and equipment to ‘craft space’ in different ways, enabling makers with limited means to jointly navigate and terraform their environment ([qamp.net](http://qamp.net)).*

Their metaphorical strategy offers a revised perspective through the use of incongruity (Fernandez, 1986), where the perceived contradictions between poverty and waste materials on the one hand, and exploratory capacity and high-tech tools on the other, provides a way to capture interest.

## Discussion: CLA in Relation to Existing Readings of Design

It could be argued that design(s) – from architecture and urbanism to product and beyond - are most frequently evaluated by the industry on two primary levels, that of functionality and construction. Here, functionality relates not only to the degree to which a product fulfills its mechanical purpose, but whether the design meets the needs of the intended user; while construction relates to the materials and processes used to craft the artefact. This crude simplification appears

to do little justice to principles reflectively laid out by adherents to particular approaches, such as industrial design (Rams, 1980), co-design (Manzini & Rizzo, 2011) or systems design (Rechlin & Maier, 2010). However, the authors would argue that underlying all such principles, notions of functionality and construction remain implicit. Even in the case of speculative design which is often geared towards an audience rather than a user, artefacts function to generate ideas outside the boundaries of what is deemed likely and are constructed according to recognised techniques in craft and design practice – and are evaluated as such. “Success occurs when an idea has been developed [in design terms] to a point that an audience can engage with it” (Ebrahim & Hastrich, unspecified).

To the extent which CLA presents a method for deconstructing and reconstructing alternative futures – not assessing an individual project circumscribed by prescriptive design requirements nor speculative propositions conceived entirely to provoke – designers can gain a deeper and more expansive model for conceptualizing both the impact and design intent of their activities. For the designers of AMP then, CLA suggests a counter-mode of comparison with/in relation to both vertical and horizontal systems of valuation that reaches beyond conventional frameworks for analysing design(s) which tend to rely on metrics of assessment. That is to say, as per above, that design(ers) too often become preoccupied with questions of functionality - “Does it work?” - at the expense of probing deeper and wider to determine and articulate the contextualized meta-project of any given design challenge.

In the case of design history and critical design theory, methods of analysis might include any number of humanities-based lenses including post-colonial studies, heritage studies, social history, structuralism, post-structuralism – the possibilities being far too exhaustive to deal with adequately in this paper. CLA’s novelty in these contexts, is not its constitutive discourses of poststructuralism, macrohistory and postcolonial multicultural theories (Inayatullah, 2014) in and of themselves; rather it is the way in which CLA acts as an ordering device for these theories with the aim of deepening stories about the future. Using the model of litany deconstruction, consideration of the issue within broader systems, examination of underlying cultural narratives and metaphoric analysis offers a manageable set of steps by which to investigate a designed artefact. Considered in reverse order, CLA reveals to the designer, design historian or design theorist the ways in which metaphor, worldviews, systems and litany *cause* particular design solutions to emerge.

## Conclusion

If CLA is understood “not [as] a statement about the future, but a method for analyzing statements or images about the future” (Ramos, 2015, p. 25), then its application to examples of design practice seems appropriate. An interpretation of the layers in relation to statements and images of the AMP design project, might offer the following levels of analysis:

1. *Litany* – dystopian media representations of exotic bodies in toxic environments versus techno-Utopian visions of Agboglobloshie as a large-scale innovation hub.
2. *System* – charting of design process including: mapping of materials and production ecosystems on the Agboglobloshie site through activities of recycling, repair and making anew; documentation of workshopping and skill-sharing; physical prototypes of AMP spacecraft
3. *Discourse and worldview* – imposed narratives of Afrofuturism by design media; self-assigned narratives of maker-oriented futures and revised DfD models by AMP designers; new narratives of Afrikological futures explored by authors.
4. *Myth/metaphor* – AMP publicity materials’ use of craft and scientific metaphors associated with maker culture and space exploration to subvert dystopian litany around Agboglobloshie.

Seen through the lens of CLA, the objective of AMP is the physical and metaphorical transformation of the Agboglobloshie site from a dysfunctional site of subsistence on waste to a site of

creativity and productivity. Ultimately, AMP has a vision of African-produced futures<sup>10</sup> and employs a model of Africa-based innovation to achieve this. The design response thus calls for approaches that prioritise supporting user-oriented ecosystems, participation among different interest groups both locally and internationally and methods that ensure safety and product/system/process repeatability. Methodologies used within these approaches include systems mapping (systems design), workshops (co-design), designer toolkit development and collaborative construction of prototypes (engineering crafts and standards).

This vision of an African-produced future(s) is supported by metaphors of makerspaces and spacecraft, where makerspaces correlate to ideas of contemporary design practice, collective activism and self-determination; and spacecraft are associated with cutting edge technology, mobile architectures and alternative worlds. Aside from re-enforcing the underpinning ideologies of AMP as they connect to maker culture, these metaphors also produce unintended connections with Afrofuturist tropes of gleaming space-age aesthetics and fictional technologies. In writing this paper, the authors were invited to consider how each of these future-facing worldviews provided a particular story of the future connected to the project. An engagement with CLA invited us to posit a broader and deeper framework for both AMP and African futures – that of the Afrikological, maker-oriented future.

For futures studies scholars, especially those interested in the intersections of futures studies and design practice - the application of CLA to design may well have been previously encountered. Futurists Stuart Candy and Jake Dunagan have been using Causal Layered Analysis as scaffolding for undergraduate students at Carnegie Mellon School of Design to learn how to inquire into and read design artefacts and query the makers of them (Candy, 2018). Futurist Peter Saul has employed CLA within commercial product environments as a means of co-producing preferable futures and then evaluating new product concepts in relation to these scenarios (Saul, 2002). Designers Santini Basra and Chris Strachan of Odd Studio have produced a set of playful design tasks and tools that can be used to workshop CLA's levels of analysis with the aim of producing a preferred future complete with design prototypes (jfsdigital.com, 6 October 2016).

However, in all of these examples, the design object itself remains either symbolic, conceptual or playful. The authors of this paper argue that the design process and principles of built artefacts - that is, the precise constraints, construction, craft and functionality of artefacts - offer integral insights into the ideology that underpins any design future scenario. This integration of the technique of CLA and the process of designing artefacts thereby offers a broader reading of the physical construction of futures.

“But, as I have tried to develop, it is this futuring that can aid in problematizing present structures and grammars, and thus create the possibility not of a recovery of the past, but of the creation of new discourses, new *constructions* of the real” (Inayatullah, 2004, p. 133).

## Acknowledgements

The authors gratefully acknowledge the funding of the Leverhulme Trust in supporting research connected to the AfriDesignX network.

[grant number IN-2015-027].

All original images of Agboghloshie and the *Agboghloshie Makerspace Platform* have been provided courtesy of DK Osseo-Asare and Yasmine Abbas.

## Correspondence

Cher Potter  
University of the Arts London  
Victoria and Albert Museum  
UK  
E-mail: c.j.potter@arts.ac.uk

## Notes

1. AfriDesignX is a Leverhulme-funded network led by Cher Potter as Principal Investigator and Mugendi K. M'Rithaa and DK Osseo-Asare as key partners and advisors.
2. By design we refer to “products, services, systems and experiences planned by a human maker”, a definition adapted from the World Design Organization’s (WDO) established definition of industrial design. (<<http://wdo.org/about/definition/>>).
3. More information about the project can be found at <<https://qamp.net/>>.
4. This particular translation of the CLA model is adapted from the text “Transcendence of a method: the story of causal layered analysis” authored by Jose Ramos.
5. As retrieved on 20 October 2018, by entering the search term Agboglobloshie and selecting the news tab - [https://www.google.co.uk/search?q=agboglobloshie&safe=strict&source=lnms&tbm=nws&a=X&ved=0ahUKEwjzdf65pLeAhXTNcAKHQhFDIIQ\\_AUIECgD&biw=1252&bih=685](https://www.google.co.uk/search?q=agboglobloshie&safe=strict&source=lnms&tbm=nws&a=X&ved=0ahUKEwjzdf65pLeAhXTNcAKHQhFDIIQ_AUIECgD&biw=1252&bih=685)
6. See geographer Josh Lepawsky’s writings on Agboglobloshie and the misconceptions around “geographies of discards” as well as the Basil Convention reports on e-waste in Africa as examples.
7. Dr Brooks is a contributing author to the recently published *Afrofuturism 2.0: The Rise of Afro blackness* (2016) as well as a co-editor on an upcoming special issue of the Journal of Futures Studies titled *When is Wakanda? Afrofuturism and Dark Speculative Futurity* (2019).
8. According to Fathers, this marks the third wave in DfD, following post-WW2 reconstruction (1940s – 1960’s) and “Appropriate Technology”/“Design for Need” (1970s – 1980’s) which offered new visions for international aid intervention.
9. It should be noted that “transdisciplinary design” is also a recognized approach to design, which emphasizes “collaborative design-led research and a systems-oriented approach to social innovation”... in which designers “work in cross-disciplinary teams” <https://www.newschool.edu/parsons/mfa-transdisciplinary-design/>
10. By “Africa”, Osseo-Asare and Abbas are referring the continent of Africa as opposed to a delineation of Sub Saharan Africa.

## References

- Aljazeera. (1 January 2014). *Ghana’s E-waste Magnet*. Retrieved from <https://www.aljazeera.com/indepth/inpictures/2014/01/pictures-ghana-e-waste-mecca-2014130104740975223.html>
- Barton, A. C., & Tan, E. (2015). *Designing Equity-Oriented Makerspaces Part I: Interrogating the Equity Challenges in the Maker Movement*. Retrieved from <https://edwp.educ.msu.edu/green-and-write/2015/designing-equity-oriented-makerspaces-part-i-interrogating-the-equity-challenges-in-the-maker-movement/>
- Borland, R. (2011). *Objects in Development*. Unpublished PhD. Retrieved from <https://objectsindevelopment.net/author/ralph-borland/>
- Bristow, T. (2012). ‘We want the funk: What is Afrofuturism to the situation of digital arts in Africa?’. *Technoetic Arts*, 10(1), 25-32. doi:10.1386/tear.10.1.25\_1
- Brooks, L. A., & Saveri, A. (1 January 2017). *Expanding Imagined Affordance with Futuretypes:*

- Challenging Algorithmic Power with Collective 2040 Imagination*. Retrieved from <https://scholarspace.manoa.hawaii.edu/bitstream/10125/41369/1/paper0220.pdf>
- Candy, S., & Dunagan, J. (2017). 'Designing an experiential scenario: the people who vanished'. *Futures*, 86, 136-153. doi:10.1016/j.futures.2016.05.006
- Candy, S. (2018). 'Gaming futures literacy: The Thing from The Future'. In Miller, R. (Ed.), *Transforming the Future*, 257-270. London, United Kingdom: Routledge.
- Covert Truth. (3 April 2017). *Agbogbloshie: Toxic Waste Dump?* Retrieved from <http://www.covert-truth.com/posts/abbogbloshie-toxic-waste-dump>
- Dazed Digital. (unknown). *Agbogbloshie: Digital Wasteland*. Retrieved from <http://www.dazeddigital.com/photography/gallery/17500/3/agbogbloshie-digital-wasteland>
- Dezeen. (16 May 2016). *Agbogbloshie Makerspace Platform creates mobile workshops for world's largest e-waste dump*. Retrieved from <https://www.dezeen.com/2016/05/16/agbogbloshie-e-waste-dump-makerspace-platform-spacecraft-mobile-architecture-workshop-ghana-julien-lanoo-photography/>
- Doctorow, C. (2009). *Makers*. Somerset, UK: Macmillan.
- Dunagan, J. et al. (2018). 'Strategic Foresight Studio: A First-Hand Account of an Experiential Futures Course'. Special issue of the *Journal of Futures Studies, Design and Futures*, March 2018.
- Dunne, A., & Raby, F. (2013). *Speculative everything: design, fiction, and social dreaming*. Massachusetts, United States: MIT Press.
- Ebrahim, Z., & Hastrich, C. (unspecified). *Design Fiction*. Retrieved from <http://designresearchtechniques.com/casestudies/design-fiction/>
- Eglash, R., & Foster, E. K. (2014). On the Politics of Generative Justice: African Traditions and Maker Communities. In Mavhunga, C. (Ed.), *What Do Science, Technology, and Innovation Mean from Africa* (pp.117–136). Massachusetts, United States: MIT Press.
- Eshun, K. (2003). 'Further considerations of Afrofuturism'. *CR: The New Centennial Review*, 3(2), pp.287-302. doi. 10.1353/ncr.2003.0021
- Fathers, J. (1 January 2004). *The role of design in development since 1945*. Paper presented at the first Gregynog Research Colloquium, Perspectives on Development 1, 2004, Cardiff, United Kingdom.
- Fernandez, J. W. (1986). *Persuasions and performances: The play of tropes in culture*. Indiana, United States: Indiana University Press.
- GIZ, (2016). *Environmentally Sound Disposal and Recycling of E-waste in Ghana (E-Waste project)*. Retrieved from <https://www.giz.de/en/worldwide/63039.html>
- Guardian. (27 February 2014). *Agbogbloshie: the world's largest e-waste dump*. Retrieved from <https://www.theguardian.com/environment/gallery/2014/feb/27/agbogbloshie-worlds-largest-e-waste-dump-in-pictures>
- Inayatullah, S. (1998). 'Causal layered analysis: Poststructuralism as method'. *Futures*, 30(8), 815-829. doi:10.1016/S0016-3287(98)00086-X
- Inayatullah, S. (2004). *The causal layered analysis (CLA) reader: Theory and Case Studies of an Integrative and Transformative Methodology*. Taipei, Taiwan: Tamkung University Press.
- Inayatullah, S. (2014). *CLA Defined*. Retrieved from <http://www.metafuture.org/cla%20papers/Inayatullah%20CLA%20defined.pdf>
- Journal of Futures Studies - jfsdigital.com. (6 October 2016). *Odd Studio's Cultureberg: Causal Layered Analysis meets Design*. Retrieved from <https://jfsdigital.org/2016/10/06/odd-studios-cultureberg-causal-layered-analysis-meets-design/>
- Leverhulme Trust, Annual Review 2015. (2015) *Design Futures in Sub-Saharan Africa*. Retrieved from <https://www.leverhulme.ac.uk/sites/default/files/Publications/LEVERHULME%20AR15%20LO-RES.pdf>
- Manzini, E., & Rizzo, F. (2011). 'Small projects/large changes: Participatory design as an open par-

- anticipated process'. *CoDesign*, 7(3-4), 199-215.
- Minter, A. (2016). *The Burning Truth Behind an E-Waste Dump in Africa*. Retrieved from <https://www.smithsonianmag.com/science-nature/burning-truth-behind-e-waste-dump-africa-180957597/#WzswtUIBi6EIpTbB.99>
- M'Rithaa, M. (5 March 2018). *Socially Conscious Design: A key strategy for addressing expansive issues encompassing the social, geo-political, economic and environmental on the African continent*. Paper presented on behalf of AfriDesignX at the LCF Research Fortnight conference 2018, London, United Kingdom.
- Nabudere, D.A. (2011). *Afrikology, Philosophy and Wholeness: An Epistemology*. Pretoria, South Africa: Africa Institute of South Africa.
- New York Times. (4 August 2010). *A Global Graveyard for Dead Computers in Ghana*. Retrieved from <https://www.nytimes.com/slideshow/2010/08/04/magazine/20100815-dump/s/20100815-dump-slide-TTVC.html>
- Osseo-Asare, D. (18 May 2018). *Agbogbloshie Makerspace Platform (AMP): The Future of Making*. Paper presented at the 5<sup>th</sup> AfriDesignX Conference 'KpaKpaKpa: Design Concepts from the African Continent', 2018, London, United Kingdom.
- Papanek, V., & Fuller, R. B. (1972). *Design for the real world*. London, United Kingdom: Thames and Hudson.
- Penn State News. (21 September 2018). *TED, Penn State and a makerspace in Ghana: DK Osseo-Asare and Yasmine Abbas design as research*. Retrieved from <https://news.psu.edu/story/537864/2018/09/21/research/ted-penn-state-and-makerspace-ghana>
- Qamp.net - Agbogbloshie Makerspace Platform project website. (2017). Retrieved from <https://qamp.net/>
- Ramos, J. M. (2015). Transcendence of a Method: The story of causal layered analysis. In Inayatullah, S. and Milojevic, I. (Eds.), *CLA 2.0: Transformative Research in Theory and Practice* (pp. 25-44). Taipei, Taiwan: Tamkung University Press.
- Rechtin, E., & Maier, M. W. (2010). *The Art of Systems Architecting*. Florida, United States: CRC press.
- Rams, D. (1980). *Dieter Rams: 10 Principles of Good Design*. Retrieved from <https://www.design-principlesftw.com/collections/ten-principles-for-good-design>
- Safo, A. (2002). *End of the Road for 'Sodom and Gomorrah' Squatters*. Retrieved from [http://africa.peacelink.org/newsfromafrica/articles/art\\_827.html](http://africa.peacelink.org/newsfromafrica/articles/art_827.html)
- Sall, A. (2003). *Africa 2025: What possible futures for Sub-Saharan Africa?* Pretoria, South Africa: UNISA Press.
- Saul, P. (2002). Using futures studies to design tomorrow's products: a case study. *Foresight*, 4(2), 21-24. doi:10.1108/14636680210435100
- Sterling, B. (2013). *Anti-conventional Objects* (diagram). Retrieved from <https://www.wired.com/2013/10/design-fiction-anticonventional-objects/>
- Tharp, B. M., & Tharp, S. M. (2013). Discursive design basics: Mode and audience. *Nordes*, 1(5), 406-409.
- United Nations News and Stories. (24 September 2018). *Turning e-waste into gold: the untapped potential of African landfills*. Retrieved from <https://www.unenvironment.org/news-and-stories/story/turning-e-waste-gold-untapped-potential-african-landfills>
- Waldman-Brown, A., Obeng, G. Y., Adu-Gyamfi, Y., Langevin, S., & Adam, A. (2014) *Fabbing for Africa's informal sector*. Retrieved from <http://citeseerx.ist.psu.edu/viewdoc/summary?doi=10.1.1.635.8804>
- Wanda, R. E. (2013). Afrikology and community: Restorative cultural practices in east Africa. *Journal of Pan African Studies*, 6(6), 1-26.
- Wired. (23 April 2015). *Inside the Hellscape Where Our Computers Go to Die*. Retrieved from <https://www.wired.com/2015/04/kevin-mcelvaney-agbogbloshie/>

# Strategic Foresight Studio: A First-Hand Account of an Experiential Futures Course

**Jake Dunagan**  
Institute for the Future  
USA

**Alida Draudt**  
Strategic Foresight Partners LLC  
USA

**JJ Hadley**  
Slalom  
USA

**Ryan Hogan**  
Mozilla  
USA

**Leticia Murray**  
Gensler  
USA

**Gregory Stock**  
Firefly  
USA

**Julia Rose West**  
Ancestry  
USA

---

## Abstract

*This article provides a first-hand account of the design, execution, and outcomes of a course in experiential futures, featuring perspectives from the instructor and all 6 students. These reflections are personal and conversational in tone, but are synthesized in the conclusion to draw out more general insights for teachers and practitioners. The*

*main lessons learned from the course revolve around the power of “telescoping” from the abstract realm of possibilities to the concreteness of constitutions and artifacts, and back, without losing contact with either. In this article we manifest multiple intellectual, personal, and institutional layers and the “real-life” dynamics involved in executing a graduate-level course in experiential futures. By drawing out some of the most important lessons and insights from the course, we hope readers will learn, incorporate, and improve upon the pedagogical processes described in their own current and future courses.*

**Keywords:** Experiential Futures, Education, Methods, 2x2, CLA, Alternative Futures, Manoa School, Governance Design, Pedagogy, Jim Dator, Design Futures, CCA.

## Plotting the Course

This article provides a first-hand account of the design, execution, and outcomes of a course in experiential futures. The course, SFMBA 670 Strategic Foresight Studio, was held in the fall of 2015 in the California College of the Arts’ (CCA) Strategic Foresight MBA (SFMBA) program. While targeted toward teachers and practitioners of foresight, anyone with an interest in futures pedagogy, including future-oriented designers, should find useful examples and reflections in the article.

This account features perspectives from the professor and all 6 students in the course—directly expressing their experiences. These reflections are personal and conversational in tone, but are synthesized in the conclusion to draw out more general insights for teachers and practitioners. The main insights and lessons learned from the course revolved around the power of “telescoping” from the abstract realms of principles and possibilities to the concreteness of constitutions and artifacts, and back, without losing contact with either.

Students spent a great deal of time thinking through the values they wanted to see in their political system designs, but also had to consider how it would look and feel to people living in those systems, and how they would represent these experiences. The Experiential Futures Ladder and Social Inventor’s Toolkit were effective scaffolds for building new structures of government and futures situations. They allowed the students to explore uncharted speculative territories, but anchored them in a rigorous process. Thus, when ambiguity or creative conflict arose, or when teams were in flux from stage to stage, there was a logical system that could be returned to in order to think carefully through first principles of foresight and experience design, but that didn’t trap the imagination in formulaic boxes.

In this article we manifest multiple intellectual, personal, and institutional layers and the “real-life” dynamics involved in executing a graduate-level course in experiential futures. By drawing out some of the most important lessons and insights from the course, we hope readers will learn, incorporate, and improve upon the pedagogical processes described in their own current and future courses.

## Situating the Course

Design-oriented futurists and future-oriented designers (including speculative and critical designers), while still defining their practice, are growing in numbers and gaining traction in business, education, and governments (Candy, 2010; Hines & Zinato, 2016). Artists are creating multi-sensory experiences that directly address future-oriented themes and issues (Dunagan, 2015). Conferences like Primer, Future Everything, and SxSW Interactive are bringing together futurists and designers to explore overlapping theories and tools (Primer, n.d.; FutureEverything, n.d.;

SxSWi, n.d.) The Institute for the Future, a non-profit foresight group, has long used design tools and artifacts from the future to deepen engagement with their forecasts (IFTF, n.d.).

Design firms Ideo, Frog, Idea Couture, and others are actively seeking out and incorporating futures concepts and tools into their design and design strategy work (Wilson, 2016; Alexander, 2016). Technology companies such as Intel, Microsoft, and Google are using speculative design to inform strategy and product development, but not without critique (Salmon, 2018). In major universities, programs and courses are emerging that explicitly combine approaches from futures and design. Stanford's Foresight and Innovation program within mediaX, UT Austin's Center for Integrated Design, and Carnegie Mellon's School of Design are just a few of the growing number of university and educational programs seeking to expand and deepen direct connections between foresight and design (Dawson, n.d.).

Why is this convergence happening? Design has in a sense, always been about the future, as the practice of design brings new "things" into the world that had not existed before. But the things that are subject to design are much broader than material objects. Constituting nations, crafting codes of conduct, and conjuring philosophical paradoxes are all products of a design approach to life. Design, like everything, lives in the present, even as it changes the course of our possible futures.

Futures studies, as a field, takes its object of study something that does not exist (as far as we can tell). "The Future" is always a construct from the present, built on the back of the past. Futurists have paid attention to design because it manifests early signals of things to come. Designers create new conditions for possibility and new adjacencies for future action.

Experiential futurists try to understand the connected adjacencies of the future by creating artificial, but tangible, immersions into these spaces. By concretizing the abstract (even though the future will most certainly be different than any imagined scenario), futurists can help connect participants with futures in deeper, more visceral, more emotionally resonant ways. Using design techniques, performance art, new media, and other emerging tools like VR, experiential futurists create spaces for exploration and edification, making new worlds thinkable and, often, makeable.

The California College of the Arts (CCA) has moved aggressively into the foresight and design strategy space. CCA was formed in 1907 and is currently located at two campuses in the Bay Area (Oakland and San Francisco, CA). The school "educates students to shape culture and society through the practice and critical study of art, architecture, design, and writing. The college prepares students for lifelong creative work by cultivating innovation, community engagement, and social and environmental responsibility" (CCA, n.d.).

In 2013, the CCA announced two new degree programs, an MBA in Public Policy Design and an MBA in Strategic Foresight. These programs were intended to build upon on the success of the innovative MBA in Design Strategy (DSMBA) program, which was launched in 2009.<sup>2</sup> As Nathan Shedroff, founder of the DSMBA program, stated at the launch of the SFMBA degree program: "forward-thinking organizations today are demanding creative leadership in the people they hire, and we are excited to respond to that demand with these new specialties," (quoted in CCA, 2013).

Into this disciplinary *mélange* of experimentation and hybridization entered the first cohort (C1) of SFMBA students. The Strategic Foresight Studio course was held in the 3rd of 4 semesters of the 2-year program. By the time the students entered the experiential futures course, they had one year of prior coursework, including more traditional business management courses, such as finance and strategic management. They had, by that time, also developed deep intellectual and personal relationships with each other.<sup>3</sup> They came from a diverse set of personal backgrounds and specialties, but all shared a pioneering spirit and a tolerance of uncertainty. They were trailblazers, and have remained so since their graduation in 2016.<sup>4</sup>

## Designing the Course

### Jake Dunagan, Professor:

With only one semester to teach these students, I included a wealth of futures content I felt was essential for their success as futurists. It was ambitious (or foolhardy) to give them the entire Manoa School of futures approach in one semester but I was determined to try. The Manoa School is defined by the alternative futures method (Jones, 1992). The method is built around 4 scenario archetypes—growth, collapse, discipline, and transformation. The approach also trains students to be social inventors, and requires students to engage in political system design (Dator, 2009). The Manoa School was the intellectual base of the course, and was complemented by other core futures methods, including the 2x2 scenario method (Ogilvy & Schwartz, 2004) (Figure 1) and Causal Layered Analysis (Inayatullah, 1998).

The structure of the course followed the Experiential Futures Ladder. The Ladder is a framework that Stuart Candy created, and he and I further elaborated for envisioning and manifesting tangible experiences of possible futures (Candy & Dunagan, 2017). Over many years, both as an internal guiding process and as a pedagogical tool, the Ladder has proven to be highly effective in helping deliver high quality, original futures work (Candy & Dunagan, 2016) (Figure 2).

The Experiential Futures Ladder has four main stages, moving from abstract to concrete: Setting, Scenario, Situation, and Stuff. The Setting is the top level descriptor or context, for example, the future of Phoenix, AZ. The scenario is a particular story about the future of the setting, so a version of a future Phoenix that is very unsustainable and water scarce. The Situation is the representative scale and real-time experience one is creating—for example, a presentation, demonstration, performance, or media interaction. The Stuff is the stuff: all of the artifacts, decorations, costumes, props, and other physical, digital, or aesthetics assets needed to execute the Situation (Candy & Dunagan, 2017).



Figure 1. JJ Hadley and Julia Rose West facilitate a discussion on the 2x2 method (Photo: Jake Dunagan)

The Manoa School provided the intellectual rigor of the course. The Experiential Futures Ladder provided the scaffolding for the design of the course. And finally, what we might call the values, or even the spirit or mood of the course was reflected in this declaration by Johns Hopkins political theorist William Connolly (2002, p. 216):

I say possibilities, not probabilities. A key role of theory is to probe the positive possibilities that might otherwise be overlooked and that, indeed, may be unrecognized because they have been generated by new [[unprecedented, changing]] circumstances of being. The next thing to do is to inspire the pursuit of those possibilities that are most desirable. Paying too much attention to ‘probabilities’ undercuts these efforts. For, most of the time, the recognized register of probabilities consists of things that are already part of the established practice. Those who pursued Christianity, secularism, feminism, gay rights, and so forth at the key moments of their emergence from below the register of established practice were not probabilists of the sort anointed by most social scientists. They were acting to bring something new into the world even more than they were watching to see what was already there. And each time a project succeeds, in a large or small way, it provides another piece of evidence, for those who will look, against the ontology of much of contemporary social science. *Possibilities are for visionaries and activists, probabilities are for spectators and consultants.* [emphasis mine]



Figure 2. An orientation to life in the 18<sup>th</sup> Territory on Mars, 2050. (Photo: Jake Dunagan)

## Running the Course

### Jake Dunagan, Professor

Using the Experiential Futures Ladder as the guide, we began with the overall Setting (subject matter) for the course — Human Settlement of Mars in 2050. In addition to Mars governance being part of Jim Dator’s undergraduate political system design course, which I was intimately familiar with, the topic of Mars was becoming ever more culturally resonant. The popular movie *The Martian* debuted that fall, and there was seemingly daily news about the planet from NASA, Elon Musk, SpaceX, and others. As we half-joked in class, “if you don’t have a space program, you’re nobody.”

For the Scenarios phase, I employed a structure I’ve been using for many years, inspired by an approach outlined by Andrew Curry and Wendy Schultz (2009) comparing diverse scenario generating techniques and the outputs and participant experiences each method generates. The assignment structure is to have students take the same topic and use different methodologies to address it. In this case, I had the 6 students divide into 3 groups of 2. For the subject of the settlement of Mars, one group would use the 2x2 matrix method, a second group would use the Manoa Alternative Futures method, and the final group would employ CLA.

This structure allows the students to have a deep engagement with one of the core scenario methods in futures studies, and learn by comparing their results to the other methods used in the class. In my experience over the past 6 years using this approach, has never failed to elicit quality futures analysis and powerful insights on the relative strengths and weaknesses of the individual methods. CLA is consistently better at pulling out hidden assumptions and amplifying deep psychological realities embedded in core metaphors. The 2x2 method brings clarity and focus to the exploration of possibilities, and the scenario logics are generative of well-defined narratives. The alternative futures method stretches participants to look at distinct zones of possibility that are highly differentiated, uncovering sometimes counterintuitive innovations and responses.

For the next stage of the course, the students were instructed to use the scenarios, and the emergent insights derived from feedback and in-class discussions, as the foundation for the creation of novel political systems for a human settlement of Mars. For this stage, I had the students use the Social Inventor’s Toolkit developed with the Institute for the Future (IFTF, 2013). The Toolkit is a process for political system design derived from Jim Dator’s UH-Manoa political system design courses, and presented as a step-by-step card deck (Dator, 1998). This process includes 1. investigating the major complaints and challenges to governance, 2. explicit declaration of one’s foundational values, cosmology, political subject, and other assumptions 3. a theoretically functional system design that embodies the foundational assumptions, and 4. prototypes, documents, and other artifacts representing the design (IFTF, 2013). In using it with groups in various workshop and classroom settings, I’ve found it provides a solid structure for systematic thinking about governance design.

Team dynamics are always critical to effective learning and performance. In a group of 6, there are relatively few combinations. Both for diversity of team experience, and reflecting the nature of the learning process for each type of assignment, I changed the team structures at each stage. The Scenario stage were teams of 2. For the System Design assignment, I had each student create one individually. The last stage, which is discussed below, the students were divided into 2 groups of 3.

The Social Inventor’s Toolkit was very useful for facilitating the design process, and even though the students were working on a highly accelerated time-frame, the designs were original and provocative. The political system designs created by the students would be critiqued by myself and 2 outside experts, with a single “winner” chosen from amongst the 6 designs. This “winning” design would provide the basis for the last major project in the course — the creation of a simulated experience that reflected life on Mars within that system.

The judging process for the designs revealed the difficulties and subjectivities of what makes a quality governance design. One judge is a highly respected designer-futurist, the other a NASA scientist working on the ethics of extraterrestrial colonization.

The judges were given the following 5 criteria to evaluate the governance designs:

1. Expression of core assumptions: did the designer make a clear explanation of their foundational assumptions about human nature, their cosmology, political subject, etc. There are no “right” answers in this sense, as the designers make those choices, but are they well-reasoned, well researched, and coherent. Score: 5(excellent) - 1(poor).
2. Does the political system design reflect and embody the core assumptions as expressed by the designer? Are the values, cosmology, theory of human nature, etc., clearly and consistently imbued in the design? Are there any glaring inconsistencies? 5(highly consistent) - 1(inconsistent/illogical)
3. Is the design plausibly functional? Would it actually work in your opinion? 5(highly functional) - 1(dysfunctional)
4. Is the design original? Are there new ideas, concepts, or approaches? 5(highly original) - 1(unoriginal)
5. Overall quality of the thinking, research, and design. 5(excellent) - 1(poor)

Looking at the judges’ scores, it is evident that evaluating political systems designs is, under these circumstances and criteria at least, a highly variable and subjective exercise. A comparison of the numeric scores only between the two judges shows in many cases how divergent the assessments were (max total 25). Remarkably, the highest score for Judge 1 was the lowest score for Judge 2, and vice versa.<sup>5</sup>

With the “winning” design selected, students were divided into two groups of 3 for the Situation stage. One group was tasked with creating an experience that represent a failure, or breakdown, of the political structure and resulting social dynamics on the Mars colony. The second group were to represent a successful, thriving system and society. Through this process, the students both “road-tested” and “threat modeled” the system and bring those insights to bear on the design of a futures experience.

In the final Residency of the course, each group had one hour to stage an experience of the future Mars colony, through the lens of a failing or thriving governing system. They had been shown many examples of experiential futures work, but were given few constraints in how they would imagine and execute their experience.

In one future, we visited a Mars colony only 10 years removed from total civil breakdown. We were led through a museum experience, guided by our Martian docents, where dozens of physical artifacts and visual media told the story of the herculean efforts over time to maintain order, and of the eventual revolt and independence of the colonists in 2050 (Figure 3).



Figure 3. Lety Murray leads JJ Hadley and Ryan Hogan on a trip to Mars in 2050 (Photo: Jake Dunagan)

In an alternative Mars, the orientation session we experienced helped us to on-board with our new fellow Martians. We were introduced to the political, social, and environmental norms and rules of the society in a very clinical, and somewhat foreboding room. Food, dirt, and rule sheets all came together under a red/orange atmosphere in a very evocative and compelling experience (Figure 4).



Figure 4. A recorded medical briefing from Mars, 2050 (Photo: Jake Dunagan)

### **Reflecting on the Course: The Student Experience**

Personal reflections from each student in the course are presented below, bringing their own backgrounds, expectations, and critiques to bear on their analysis of the class. These reflections provide first-person insight into the course, and show how idiosyncratic responses can be born of a common experience. These personal reflections come directly from all six students of the course, written 9-months after the end of the course, and three months after graduating from the SFMBA program.

#### **Alida Draudt**

This course was pivotal in my SFMBA experience. Through it, the tension between visioning and practicality was ever-present. It emphasized the necessity of periodically stepping back from immersive work to understand the larger context and potential implications.

#### **Experiment first – then layer on the logic**

A key success factor for this course was that it came during our 3rd semester (of 4). Given this timing, we had the ability to explore and experiment with several design strategy and foresight tools prior to engaging in this class. Previous exposure to the 2x2 matrix, alternative futures, and social innovation (experiential interventions) made the jam-packed semester within reach. Trying and failing to use several of these tools prior to understanding precisely how and why these methods worked was one of the largest learning experiences for me. The course had the effect of lending logic and process to my previously disorganized and exploratory work. There is both an art and a science to futures studies; learning in layers helped me better understand just how important both aspects are.

#### **The power of divisiveness**

Designing a system of governance for a colony of 50,000 individuals (both human and AI) on Mars in 2050 was both the most challenging and left the biggest impact. By using the Social Innovator's Toolkit to think critically about my own values and beliefs regarding the nature of the human race, this exercise resulted in an extreme design – something I called the Mars Anarchy. Using elements of the human nomad lifestyle, how large or small naturally forming groups tend to

be, and my thoughts on natural human values and beliefs, my design was unusual – it was one of the most divisive designs of the class. Some judges loved it, others despised it. What this taught me, however, is that some of the most interesting discussions are born out of conversational conflict. I must admit, where divisiveness in my own work previously created personal discomfort, I now pointedly seek divisiveness out to stimulate rich, sometimes shocking, but undeniably fascinating debates.

### **(So much) More than professional dreaming**

While immensely fun, foresight work is based solidly in rigor, research, and detail. Engaging fictions can be written about any number of fantastical futures based loosely on the present. Fantastical futures, however, have difficulty translating to the real world. This course helped me develop a skill for creating visions of the future that are not only a blend of novel, intriguing, and ambitious, but also rooted in the nature of humans. It is a delicate balance, but a skill I continue to use today across a broad range of topics.

### **JJ Hadley**

The course was incredibly rich. It challenged you “horizontally,” stretching the limits of your perception, as well as “vertically,” deepening your rigor and ability to get-smart-fast on a given subject. In retrospect, what stands out for me is the courses focus on the unique value and growing need for experiential futures work – why we must “evidence futures” so clients can experience them, not just think and reason about them.

Something the course did particularly well was teach students to balance human factors, storytelling, and immersive experience design required to present evocative possible futures, with the research, academic rigor, and business applicability needed to deliver a quality futures product. This output was very much rooted in Dunagan and Candy’s collaboration and modeling of the Experiential Futures Ladder.

The value of this approach and type of futures work is in its potential to expand the client’s thinking in new or even radically divergent directions. Even more valuable, is its capacity to install a new context around a possible “tomorrow” that is rich, plausible, and applicable enough to compete with entrenched perceptions, assumptions, and certainties of “today.”

By comparison, futures work that simply “brings people along” with the intent of having them understand the characteristics of a possible future is often diluted down to an abstract or academic exercise. More often than not, the results and applicability of this kind of futures work is fleeting and of questionable value (from the client’s perspective) – even when aligned with objectives, innovation, and strategy.

However, futures work that seeks to transport people experientially into a living breathing set of circumstances with the intent of “de-familiarizing the present” to overcome “cognitive bias” has distinct transformational potential and lasting effects. This is especially true when aligned with strategic objectives, innovation, and decision-making processes.

### **Julia Rose West**

Left to our own devices we would have grouped by gender – three women and three men. One year into our education, we knew the strengths and weaknesses of our teammates. The assignments and team requirements promptly shook up those patterns before they started.

### **You are not alone**

For the first phase I was paired with Ryan Hogan. Ryan, a strong writer, is thoughtful in his point of view and analysis. Ryan and I selected the Causal Layered Analysis (CLA) as a framework

for scenario development. The discovery focused on why people would want or need to go to Mars. Research began by identifying signals, trends, and emerging issues such as: the privatization of space travel, a growing interest and a quest for enlightenment and widespread global connection to name a few.

We plotted our research onto the CLA framework and these four scenarios for Mars colonization unfolded:

- Scientific Exploration – The Mars colony is man’s modern day West Indies.
- Religious Manifesto – Mars is more tolerant of our lifestyle and religious point-of-views.
- A New Awakening - The last generation had Burning Man; this generation has the Mars expedition.
- Escape Pod – A select few were chosen to leave earth in order to maintain human civilization.

At first the CLA technique appeared daunting and the framework somewhat nuanced and difficult. However, after using it to this extent I have come to realize that it is a natural framework for effectively shaping possible futures.

### **You are alone**

For the second phase we worked individually. We were tasked with designing an innovative governance system for Mars, 2050. The Social Inventor’s Toolkit framework provided both scope and a step-by-step guide for systems consideration. Without this framework, deliberate and intelligible designs would have been impossible to devise in the short time allocated.

### **A team endeavor**

For the final phase we were divided into two teams. I was paired with Ryan Hogan and JJ Hadley to envision a thriving and successful system. My governance design, based on values, involved collaboration with children – in this system we designed the future with children and not for children. When I designed the system I really went to the heart of my values. The exercise codified that values are the heart of a lot of decisions especially in creating governance systems. The other team chose to break the system and identified child labor to collapse the world.

We were asked to transform a hypothetical Mars future into real-world experiences. Ryan, JJ, and I attempted to appeal to all human senses. We covered all light sources in the room with red velum to cast a red glow over the room. We wore lab coats and provided lab coats and name tags to each spectator. We displayed examples of failed past experiments on pedestals. We recorded testimonials and good luck messages from previous lab participants; we offered really bad mars food, chalky dry bars and cloudy water for drinking. Using red sand, we designed an interactive ritual for new lab participants. Finally, JJ arranged for a musician to play customized music, helping to further transform the environment and drown out external noise and distraction.

We assigned in-world roles for spectators – when they entered the space they were asked to adopt the personas of newly appointed Mars innovators. By having them actively participate in our worlds, instead of merely watching from a distance, it was easier to convince them of the plausibility of the scenario. Experiential futures put the spectators and participants into the imagination of those trying to paint a picture of a future. The future is hard to envision and even harder to believe. Experiential futures allow us to time travel and temporarily be part of that distant possible reality.

## Ryan Hogan

This course offered critical reflections at each phase of the process that were key to our learning. The experiential futures forced us to evaluate and consider all opportunities and weaknesses of Mars colonization scenarios. As a studio course, it diverged from the traditional hierarchy of knowledge by taking a learn-by-doing approach. Experiential futures created an intimacy and knowledge of governance design that couldn't have been achieved otherwise.

Ultimately, the future is an abstraction. We are unable to know how it will exactly play out. By virtue of this, when bringing a future scenario to an audience, this has to be done through touch points that the viewer can relate to from the present. Through this intimate exposure to different methods of futures studies, I have found some parallels to my art making practice which preceded my time in CCA's foresight program. For my art practice, I attempted to make non-representational "artifacts" but without careful consideration, these forms could easily become too "other" and become rendered completely inaccessible to the viewer. Without certain grounding, future scenarios can also fall prey to the same outcome. Inaccessible futures are not very effective for challenging or changing the views of the intended audience.

With my natural gravitation towards ambiguity, I selected to create scenarios using the causal layered analysis method. When evangelizing the futures practice to clients, I can see the difficulties that would accompany pitching this method; however, it is the method which resonates with me the most. CLA may not be initially viewed as the most "practical" for profit-oriented clients looking to grow or shape businesses, but this method arrives at rich insights for how humans operate and interact with one another. This is something very valuable to any client, but especially so for the assigned topic of Mars colonization and the ensuing governance project. The systematic exploration challenged the core assumptions about why individuals would even choose to go to Mars, and how those motivations and values would influence their behaviors after they have colonized.

Through my experience at CCA, much of the work was done in concert as teams. It did seem strange at first that governance design was one of the few things that was not done by committee. Doing this as individuals highlighted the difficulties of changing complex systems. It also highlighted that some of these established systems actually do have merit and explain why they have some degree of longevity. With that being said, such systems are still in dire need of innovation. This class tempered my overly techno-optimist views that advancing technology would miraculously ameliorate our problems. The future is built by several disparate, sometimes conflicting voices. Arriving at a preferred outcome will require rigorous, intentional, human-focused design.

## Gregory Stock

### Failing, moving forward to possibilities

As a foresight practitioner, teasing out our own biases, experiences, and learning to trust our developing aesthetic is vital. Trying to juggle these pieces can be a problematic at times. Learning to claim the mistakes and moving past them was integral to the Foresight Studio. The class allowed us to exercise our intellectual capacities (not often found in traditional MBA programs). The entire semester was an opportunity to conduct deep dives into theories and research.

We had a big question ahead of us: How might we imagine governance on Mars? As I researched governance and utilized the frameworks in our toolkit, I found myself attracted to theories of the past to inform the future. Personally, I found this large governance challenge led me to central questions of human values. How do we imagine an equitable society in the future? What are the true possibilities of colonizing space? Theories by economist Elinor Ostrom (1990) and theorist Judith Butler (2013) were foundational in my exploration of this "future commons" in Mars. As a designer, I was able to truly flex my foresight muscles and experiment with theories that

existed in our present day.

After each project in the class, we built towards creating a new experience. Working in teams in developing a successful experience had its own challenges. What was the ultimate goal of our governance experience? We had to decide on how to present brand new ways of thinking, transporting participants to Mars and exploring scenarios never before heard. I realized the more practice at communicating new ideas I would get, the better I would be at bringing my audience along into new visions of the future (Figure 5).

While reflecting on the studio, it was one of the rare moments that a professor challenged us to put existing systems behind us and try to innovate new ones. At times, we failed and we were wrong. These constraints and learnings pushed us to new ways of activating foresight techniques. Ultimately, we expanded our paradigms of what might be possible for our clients (and ourselves) in the near future.



*Figure 5.* Gregory Stock returns to Earth, 2015 (Photo: Jake Dunagan)

### **Lety Murray**

Trained as an architect and currently discontent with where I found myself heading in the profession, only designing to solve immediate problems, not looking beyond the scope or other issues that could impact our work in the future, I found myself attracted to the SFMBA program at CCA. A program that could help me not just visualize but also vocalize societal issues in need of acknowledgment, give a voice to those often overseen and to better design a future for all.

The Strategic Foresight course in our third semester allowed me to revisit the systemic thinking from my previous training and combine it with the foresight tools we had been exposed to in the semester prior, to imagine what it would take to successfully inhabit Mars by 2050.

### **Exposure to tools does not equal mastering**

To this day, we learn more each and every time we use one of the tools/methods we acquired throughout the degree. During the first phase of the course, we generated scenarios using alternative foresight methodologies, my partner Gregory Stock and I were tasked with using the 2x2 Matrix method. We began by asking ourselves who would be a Martian in 2050 and what through our research would be the two most significant uncertainties that would shape the possible futures. Our two uncertainties, *Political Ideologies*-ranging from the belief in Anarchy to a Reign of Terror, and *Societal Values*-that ranged from Uniformity to valuing Diversity, formed the two axes for our 2x2. This method allowed us to create the following four clearly distinct scenarios:

- **Design for Servitude** “The Human Race proves to be heinous.”
- **Utopian Mars** “Some are more equal than others.”
- **The Red Military** “Military coup on Mars; Communications to Earth cut, leads to confusion”
- **The Melting Pot** “Moon as breeding ground proves successful, Martian animal species takes hold.”

Each one unique in its own way, with its own advantages and disadvantages. However, coming off the previous semester’s high of discovering *Science Fiction Prototyping*, we found ourselves pushing even further into the future, perhaps beyond 2050 and getting caught up in the details instead of focusing on the implications of what was at stake and who it would affect. We know this now, but it was only possible having gone through this experience and receiving the feedback from Jake and our peers.

### **Pushing Boundaries through Frameworks**

Without the use of the Social Inventor’s Toolkit, I’m not sure we would have imagined the six distinct governance systems in the short timeframe the course allowed for. At this point in our program, we learned to manage the difficulties of working in teams and actually looked forward to being a team of one, so the thought of designing a governance system on my own was just overwhelming. The Toolkit provided a framework that allowed me to question my values and beliefs, to question current governance system and imagine multiple possibilities for future systems in a clear and cohesive matter while maintaining my sanity.

### **Experiencing the Future**

By far, hands-down my favorite part of the course was in the final stage. Not only were we back in teams, but this time we were able to put together a physical experience, that not unlike Architecture would inspire you and transport you to another state of mind, to another world. Through the creation of a future Martian museum exhibition set in 2060, we retold the story of the Martian Revolt of 2050. A carefully curated tour led visitors through the collection of artifacts, images and Revolt paraphernalia. Afterwards guests were invited to partake in a conversation as the last surviving members of the Martian Collective, brought together to discuss the error in their ways, to rectify the revolt, and to explore what the future may hold.

This course solidified my decision in having chosen a graduate degree that focused on Strategic Foresight. It allowed me to come around full circle and continue using design to shape the world,

yet this time through a much broader lens with a new set of tools to explore alternative futures, all while embracing uncertainty.

## **Conclusions: Learning from the Course**

The institutional and design context, as well as the personal narratives, were intended to help readers understand the multiple dimensions of learning that took place in the course. The depth of engagement and quality of work is due to the remarkable commitment of the students, and the willingness for all to take an attitude of full-bodied experimentation. Speed can make knowledge a blur, but it can also make manifest the essential nature of systems, as in behaviors and interactions seen through time-lapse photography.

There were several core lessons taken from the course—lessons that should be applicable to foresight instructors and practitioners, as well as future-oriented designers and design strategists. First, mind matters. Students were asked to carefully examine their own assumptions about the future and what kind of future mind they have and want. This internal assessment helps one understand the futures mind of others, and find capacities and blind-spots that commonly exist. JJ Hadley recalled the concept of “defamiliarizing the present,” while Ali Draudt acknowledged and then sought out the benefits of divisiveness to provoke new ideas and directions. To break from habits of thought about governance, and following the insight that Jim Dator had long ago, we put our inhabitants on Mars, and offered more of a “blank slate” with which to start the political system designs.

Second, by covering multiple futures methods (2x2, CLA, Alternative Futures) around a common topic (Mars 2050), students were able to practice the methods, and importantly, to see the relative strength and weaknesses in each. We had extensive discussions about how each method opened one up to differing perspectives, and changed the language and mindset of how a user would approach a topic. This included the multiple team formations that generated insights into how to express and navigate one’s own values and those of others into a coherent whole, as Julia West observed.

Third, and finally, one of the most important insights from experiential futures was confirmed: that to make futures thinkable, you must first make it feel-able. The physical metaphors used by the students, e.g. “learning-by-doing” (Hogan), “flex foresight muscles” (Stock), “vocalize” (Murray), signal the importance of spatiality and embodiment to making futures matter.

The advantages and disadvantages, the benefits and the loopholes, of the “winning” governing system were felt on and in the bodies of the students in the experiences, and gave a deeper level of understanding to those pluses and minuses than a written or strictly oral critique would have done. The experience is not the “work” of experiential futures: mind change and ultimately system change is. But mind change is connected to embodied experiences of situations and the capacity for mental simulation of future scenarios. Experiential futures is a key tool for doing better, deeper, more impactful futures work. The students left the course better prepared to use these tools in their lives and careers.

## **Correspondence**

Jake Dunagan  
Director, Governance Futures Lab  
Institute for the Future  
USA  
E-mail: [jdunagan@iftf.org](mailto:jdunagan@iftf.org)

## Notes

1. The name of the Public Policy Design program was later changed to MBA in Civic Innovation. The program was “launched” in February 2015, but no cohort was ever created. The SFMBA was on very unstable ground as well. This “existential threat” loomed over the educational experience of the students in the course.
2. The DSMBA program has offered a second-year elective in Strategic Foresight since its inception. The course was first co-taught by Jay Ogilvy, a founding member of the Global Business Network and originator of the 2x2 scenario matrix method, and Stuart Candy, an experiential futurist currently on the faculty in the School of Design at CMU. The second iteration of the course was taught by Stuart Candy and Jake Dunagan. For more information and history of the course, see Candy (2010) *Strategic Foresight*, in *Design Strategy in Action*, Shedroff, N., editor. Retrieved from [https://www.researchgate.net/publication/305724413\\_Strategic\\_Foresight/citations](https://www.researchgate.net/publication/305724413_Strategic_Foresight/citations)
3. The SFMBA, like the DSMBA, is designed in a low-residency model, wherein students (and professors) who are working full-time, or are not local to San Francisco, can commute in once a month. This works well for an intense and content-rich experience during each residency, but also requires attention to the month-long gaps between Residencies.
4. Ultimately, the SFMBA only lasted two years as a stand-alone program, closing after the second cohort graduated in 2017. However, foresight is not dead at CCA. New program chair Andy Dong has made strategic foresight a requirement for all students in their first semester, and remains an integral part of the DSMBA experience.
5. Raw scores for the governance design assignments. Judges used the same criteria, yet came back with significantly differing opinions. (Table 1)

Table 1. *Raw scores for the governance design assignments*

	Judge 1 Scores	Judge 2 Scores
Student 1	10	15
<b>Student 2</b>	<b>23</b>	<b>14</b>
Student 3	17	15
Student 4	16	16
<b>Student 5</b>	<b>5</b>	<b>19</b>
Student 6	22	16

## References

- Alexander, L. (2016, October 20). Can this board game prepare you for the future of work? *Fast Company*. Retrieved from <https://www.fastcompany.com/3064791/can-this-board-game-prepare-you-for-the-future-of-work>
- Butler, J. (2013). *Dispossession: The Performative in the Political*. Polity.
- California College of the Arts. (n.d.). About page. Retrieved from <https://www.cca.edu/about>.
- California College of the Arts. (2013, October 14). CCA launches two new MBA programs. *CCA Public relations*. Retrieved October 1, 2017, from <https://www.cca.edu/news/2013/10/14/california-college-arts-launches-two-new-mba-programs-mba-strategic-foresight-and>
- Candy, S. (2010). *The futures of everyday life* [doctoral dissertation]. University of Hawaii at Manoa, Department of Political Science.

- Candy, S., & Dunagan, J. (2017). Designing an experiential scenario: The People Who Vanished. *Futures*, 86, 136-153.
- Candy, S., & Dunagan, J. (2016). The experiential turn. *Human Futures*, (1) Dec, 26-29.
- Connolly, W. (2002). *Neuropolitics: Thinking, culture, and speed*. University of Minnesota Press.
- Dator, J. (2009). Alternative futures at the Manoa School, *Journal of Futures Studies*, 14(2), 1-18.
- Dator, J. (1998). The future lies behind! Thirty years of teaching futures studies. *American Behavioral Scientist*, (42)3.
- Dawson, R. (n.d.). University futures and foresight degrees and programs. Retrieved from <https://rossdawson.com/futurist/university-foresight-programs/>
- Dunagan, J. (2015). A sensible future. *XSEAD*. Retrieved from <http://xsead.cmu.edu/sets/34>.
- FutureEverything. (n.d.). Future sessions. Retrieved from <http://futureeverything.org/festival/2018/>
- Inayatullah, S. (1998). Causal layered analysis: poststructuralism as method. *Futures*, 30(8), 815-829.
- Institute for the Future. (2013). An inventor's toolkit. *Governance Futures Lab*. Retrieved from <http://www.iftf.org/our-work/global-landscape/governance/governance-for-the-future-an-inventors-toolkit/>
- Institute for the Future. (n.d.). Artifacts from the future. Retrieved from <http://www.iftf.org/what-we-do/foresight-tools/artifacts-from-the-future/>
- Jones, C. B. (1992). The Manoa School of futures studies. *Futures Research Quarterly*. 8(4), 19-25.
- Ogilvy, J., & Schwartz, P. (2004). Plotting your scenarios. *Meadowlark Institute Report*. Retrieved from [http://www.meadowlark.co/plotting\\_your\\_scenarios.pdf](http://www.meadowlark.co/plotting_your_scenarios.pdf).
- Ostrom, E. (1990). *Governing the commons: The evolution of institutions for collective action*. Cambridge University Press.
- Primer, (n.d.). Transformation and possibilities. Retrieved from <https://primerconference.com/2018/>
- Salmon, F. (2018). The creepy rise of real companies spawning fictional design. *Wired*. Retrieved from <https://www.wired.com/story/the-creepy-rise-of-real-companies-spawning-fictional-design/>
- SxSW Interactive sessions. Retrieved from <https://www.sxsw.com/festivals/interactive/>
- Wilson, M. (2016, November 7). Frog's 5 steps to predicting the future. *Fast Company*. Retrieved from <https://www.fastcompany.com/3065080/frogs-5-steps-to-predicting-the-future>



# Designing Futures From the Inside<sup>1</sup>

Anne Burdick  
Art Center College of Design  
USA  
University of Technology Sydney  
Australia

---

## Abstract

*By looking at the design process of a narrative-based design fiction, this paper introduces new areas of exploration for futures practices concerned with human-scale futures — the internal worlds of daily lives. Called Trina, the design fiction imagines new practices through the simultaneous creation of storyworld, prototypes, characters, and plot, with an emphasis on relations as opposed to things. By theorizing the design fiction creators as participant-observers in a world that emerges from a field of forces (Ingold, 2013), the paper concludes with questions that arise from a method that may help explore the interconnectedness of futures “from the inside.”*

**Keywords:** Design Fiction, Critical Design, Everyday Life, Making, Design and Futures.

---

## Introduction

This paper will look at how the making of a narrative-based design fiction in which storyworld, prototypes, characters, and plot were developed in tandem allowed its creators to experience a future “from the inside.” Accessing futures through a subjective lens can be challenging given the speculative nature of futures and the impossibility of a firsthand future experience. But there are ways for futures practitioners and stakeholders to get close — and to gain insights and foresights through trying — which is an aspect of the research taken up by Integral (Slaughter, 2018), Experiential (Candy, 2010), and Everyday Futures (“Everyday Futures: About,” n.d.).

Building upon Tim Ingold’s account of “making,” this paper argues for seeing the design fiction maker as a participant-observer who joins up with a world of forces in the creation of an emergent future (Ingold, 2013) that incorporates specific configurations of people and things. In particular, the paper studies the dynamic components that comprise a narrative-based design fiction, called *Trina*, which combines the tangible and visual dimension of design with the inner lives of literary figuring. *Trina* resulted from a collaboration between myself, a designer, and short story writer Janet Sarbanes (*Army of One, The Protestor Has Been Released*).

*Trina*’s plot follows the compromises, risks, and hacks that the titular character undertakes on a day-to-day basis as she negotiates with the infrastructural realities and next-generation technologies that shape her livelihood, from the sensors embedded in her body to the knowledge management system of her employer. The

mismatch between systemic forces and *Trina's* daily reality and personal biography is what powers the narrative. Thus, *Trina* enacts how individual agency intersects with histories, environmental conditions, technological capacities, and social, political, and economic networks. The author's experiential understanding of this entanglement resulted from an open-ended creative process, an "art of inquiry," (Ingold, 2013) that provided a firsthand experience of a first-person world.

By interrogating the process, this paper hopes to introduce new questions and areas of exploration for Futures practitioners, design researchers, and technology developers who aim to:

- explore the impact and viability of future technologies within particular future situations
- interact with forces that might affect agency for particular actors within particular future conditions
- test how specific individual motivations might give rise to new practices and social configurations within distinct future conditions
- adopt perspectives other than one's own
- enrich one's own 'futures literacy'

## A Case Study, Part A: *Trina*

*Trina* is a narrative-based design fiction that was created to research the use of technologies in humanities scholarly production in a plausible near-term future in order to question the trajectories being built into today's Digital Humanities tools. Based upon research into relevant nascent technologies, the project brief required that the end result meet demands that are typically identified for [1] design fiction, [2] literary fiction, and [3] futures practices. Thus, the outcome had to: [1] show prototypes in use in a storyworld; [2] tell a compelling story; and [3] motivate an audience to consider the future effects of their present choices and conditions. While [3] seems like the most likely topic for an article in the *Journal of Futures Studies*, this paper concentrates on the surprising insights gained from the author's experience of simultaneously creating [1] and [2] — what we will call a narrative-based design fiction — and its relevance to futures practices.

*Trina's* format combines showing (design) and telling (literary fiction). Its primary medium is a live performance comprised of a slide show with spoken narration and live electronic sound, but it can also be experienced as a graphic novel or a short movie (Figure 1). The story's structure can be understood as a cross between a PechaKucha (20 slides, 20 seconds each) and *La Jetée* (Chris Marker's short science fiction film comprised of voiceover and stills). The format intermingles the visible and invisible forces that give shape to the protagonist's world and actions. A sequence of 60 composite images show what appears to be *Trina's* first-person perspective above a third-person panoramic image while an omniscient narrator with access to *Trina's* thoughts tells the story (Figure 2).

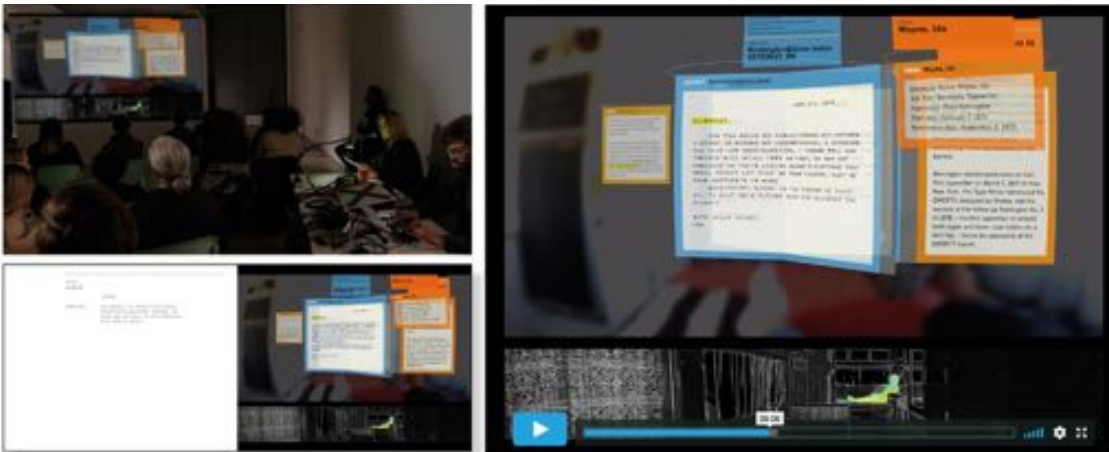

Figure 1. A moment in the *Trina* story in three different media, clockwise from top left: live performance with slide show, spoken narration, and live electronic sound; movie with voiceover narration and recorded electronic sound; graphic novel/script

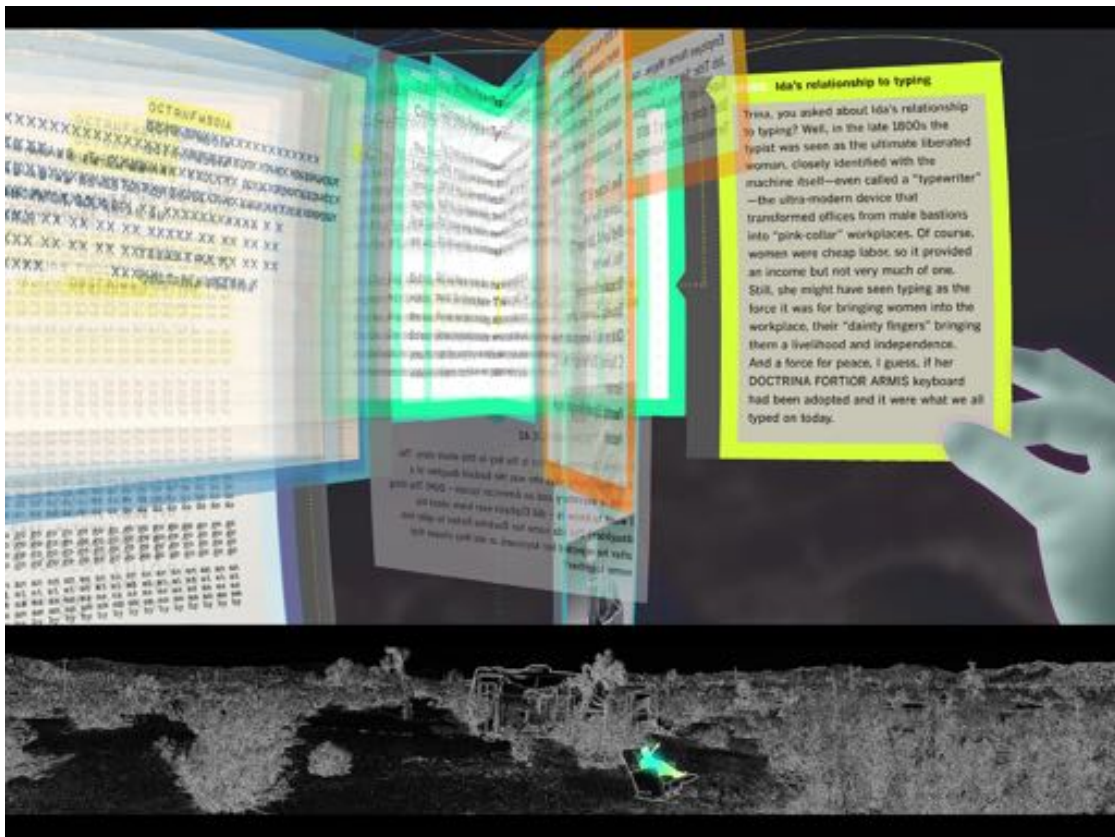

Figure 2. Slide 52. A single moment captured from two different points of view: above, Trina's first-person perspective and the spindle interface of the Commons as seen through her embedded eyewear; below, a third-person panorama shows Trina in her environs — a La-Z-Boy recliner in the desert

Trina is an underemployed literary scholar who lives alone in the desert sometime in the near future. She is connected to others through an always-on virtual world that she accesses through eye, ear, and finger implants with which she performs human intelligence tasks (H.I.T.s) for a security research firm called Humanitas, Inc. In the story we see Trina working with a variety of speculative software applications (Fuller, 2003) in between dealing with daily life in an off-the-grid RV that is powered and connected through solar and satellite. The assignment that sets the story in motion is a historical document of ambiguous provenance that is thought to have been created on a code-generating typewriter in the early 1900s. Although it is a low-stakes assignment compared to Trina's work in the War on Terror, the human-technology relationships it exposes stirs something within her and she chooses to abandon the systems that define her work and worth. It is meant to be a plausible, if complicated, future — rather than a preferable one — and Trina is a complicated woman.

Though Trina is physically alone, the story is populated with other figures who she encounters while doing research in her online environment; she communicates with amateur historians, academic scholars, and an “outdated” AI therapist called NANCY. She deduces that there may be two possible authors of the document she is researching as she pieces together parts of their lost histories: Ida Wayne was a secretary at the rifle manufacturer Remington & Sons in the late 1800s during the time that one of the first typewriters was being prototyped; Doctrina Fortior was a concrete poet who was part of the American expat literary community in Paris in the early 1900s and may be Ida's bastard daughter. Like Trina, each historical character's relationship with her writing technology is conflicted, shaped by gender, class, education, occupation, historical context, and personal biography. The tensions give rise to new practices and acts of resistance, driven by individual personalities and motivations, in response to the pressures of each character's unique situation.

## Human-Scaled Futures

Images of the future, such as scenarios, are used in foresight practices to explore what might happen in possible, probable, and preferable futures, stretching the thinking of practitioners and stakeholders alike (Candy, 2010). But Futures work focuses predominantly on the observable exterior world and large-scale and complex issues, over long-range time spans, especially in forecasting and planning (Slaughter, 2018). Approaches to accessing the human-scale of futures — internal worlds and the details of daily life — are less common.

Critical Futures Studies, along with Causal Layered Analysis and Social Constructionism, addressed the symbolic aspect of social futures, by accounting for worldviews, paradigms, and values. Nonetheless, Critical Futures work “lacked something essential — deeper insight into the nature and dynamics of individual agency” (Slaughter, 2018). To balance out the range of perspectives addressed by Futures practices, Integral Futures (IF) brought Integral Theory's holistic approach to the construction of reality through a modification of its four-quadrant map, which Slaughter advocates using to analyse Futures work. The quadrants include: the individual interior, or subjective dimension; the collective interior, or the intersubjective; the individual exterior, or objective; and the collective exterior, or interobjective (Slaughter, 2018). Yet in his assessment of the impact of IF, Slaughter (2008) concluded that none of the Futures approaches that were prominent at that time — ‘maps of the future,’ scenarios, T-cycles, CLA exercises, and environmental scanning — engaged the interior individual. The challenge has since been taken up through theories of the everyday and the experiential.

“Everyday Futures,” part of Social Futures at Lancaster University, brings together “futures research, studies of everyday life, and social practice” (“Everyday Futures: About,” n.d.). The interdisciplinary network is dedicated to developing methods to make, perform, and study the

granular details and daily practices of future everyday lives proposed or implied through both imaginative and analytic means. Like IF, they see a need to bring a human-scaled perspective to broad future visions with the aim of revealing assumptions and addressing gaps that social theory can help identify (Kuijer & Spurling, 2017). “Everyday lives vary across generations and across the life-course, across time and space, across the seasons, and across cultures and countries of the world. We think that finding methods and processes of future-making that are capable of capturing these differences, and forms of analysis that explore how they are made in the first place, is an area ripe for development” (“Everyday Futures: About,” n.d.).

Indeed, “The Futures of Everyday Life” is the title of Stuart Candy’s doctoral study of an approach he calls Experiential Futures (Candy, 2010). He and his frequent collaborator, Jake Dunagan, are similarly concerned with the subjective experience of everyday futures and to that end have done in-depth work developing methods they concisely define as “the design of situations and stuff from the future to catalyse insight and change” (Candy, 2015). “Situations” and “stuff” come from the “Experiential Futures Ladder” which was created to guide their work. The Ladder is topped by *Setting*, a kind of future, within which are *Scenarios*, specific narrative sequences, that contain *Situations*, particular places and times, that are populated by the tangible artefacts of *Stuff* (Candy, 2015). Integrating design methods, including design fiction, they ground their work on the lower end of the ladder, putting people in touch — sometimes literally — with everyday future things.

“In traditional futures practice, abstraction is clearly favoured, and high-level scenarios often lack a sense of the human, 1:1 scale. Yet there are urgent and decisive reasons for bringing futures out of the realm of cognitive abstraction and into experience; into the body...” (Candy & Dunagan, 2017, p. 2). Their work aims to “bridge the ‘experiential gulf’ between life as it is apprehended, felt, embedded and embodied in the present and on the ground and the inherently abstract notions of possible futures” (Candy & Dunagan, 2017, p. 15). One of their techniques, called Experiential Scenarios, involves co-creation of visceral firsthand futures for/with stakeholder-participants. By interacting with a human-scaled world, participants consider potential futures through their own subjective experience (Candy & Dunagan, 2017).

## From Firsthand To First-Person

Firsthand experience is a potent mode of engagement — one whose strength lies in situated and embodied action (Dourish, 2004), a key concept from science and technology studies, that demands attentiveness to “specific configurations of people and things” (Suchman, 2006, p. 284), a concept we will return to. But the strength of hands-on engagement is also a built-in limitation. The benefits of activities such as Experiential Scenarios are restricted to those who can participate in person which means that the range of perspectives brought to the scenarios may be restricted. We are left with the question of how to access the individual interior of people other than futures practitioners and workshop attendees, a concern shared with the Everyday Futures initiative.

From the standpoint of narrative, Experiential Futures could be said to provide a first-person perspective, putting an individual inside their own fictitious world to directly engage with its unfolding. Literary fiction’s first-person narration simulates this experience through language that allows a reader to “see the world through a character’s eyes,” to provide a kind of secondhand access to a character’s inner thoughts and motivations. Similarly, third-person narration, particularly that of an omniscient narrator, can disclose the inner dimensions of multiple characters, making it a promising surrogate for accessing the individual interiors and agency of people other than one’s self who are imagined to occupy potential futures.<sup>2</sup>

While the definition of “design fiction” continues to be the source of rich debate (Auger, 2013; Bleecker, 2009; Blythe & Encinas, 2016; Hales, 2013; Lindley & Coulton, 2015; Sterling, 2009,

2017), this paper asserts that it is the marriage of design's focus on human-made settings and stuff combined with literary fiction's focus on inner lives, actions, and consequences that can make design fiction relevant to Futures inquiry concerned with the human dimension. "Simulating a coherent narrative world inhabited by characters engaged in the resolution of some conflict forces us to think about the interplay between technological futures and sociological futures" (Tanenbaum, Pufal, & Tanenbaum, 2016, p. 4). Characters bring agency, values, and motivations that can shape — and be shaped by — imaginary worlds. Tapping into the entanglement of interior and exterior lives could enrich the kinds of futures we bring into being.

Narrative, especially science fiction and scenarios, has been used to investigate futures for years (Mcdowell & von Stackelberg, 2015). But Futures Studies has a shorter history with design fiction (Candy, 2010). Tanenbaum et al. (2016) argue that design fiction fits within Futures Studies, for it can open a space for public discussion of difficult potentialities. While the design aspect can make future possibilities tangible, "fiction, as a research tool, allows us to do several important things with proximal futures: it allows us to adopt a range of different intellectual commitments and values about the future and explore the consequences of those commitments" (Tanenbaum et al., 2016, p. 1). Furthermore, while design practices, such as speculative design (Dunne & Raby, 2013) and human-computer interaction (Dourish & Bell, 2014) may also be concerned with futures, particularly in relation to new technologies, design fiction explicitly involves *diegesis*, a distinction used in film studies to refer to the materials that are part of a film's on-screen narrative world. The terminology is a reference to what is widely considered to be the founding definition of design fiction asserted by science fiction author Bruce Sterling (2017): "the use of diegetic prototypes to suspend disbelief about change."

Diegetic prototypes were named as such by film scholar David Kirby "to account for the ways in which cinematic depictions of future technologies demonstrate to large public audiences a technology's need, viability and benevolence" (Kirby, 2010, p. 41). Kirby studied how filmmakers and science consultants use cinematic means to generate funding and interest in technologies that might be difficult to build in the here-and-now. To be effective, he maintains, diegetic prototypes must be plausible extrapolations of emerging technologies — not fantastical flights of fancy — that enter the social sphere when their use and consequences are demonstrated within a story and its world. Sterling and Kirby both celebrate what design can achieve that literature cannot (Sterling, 2009), which as Kirby puts it, is a "combination of a visual rhetoric along with narrative integration" (Kirby, 2010, p. 41).

Integration is the key word here, a defining aspect of what this paper proposes as narrative-based design fiction. Next, we will look at how bringing together literary figuring with a designed future world positioned *Trina's* co-creators (myself and Janet Sarbanes) as observer-participants in someone else's world, that of the lead character. Similar to *Experiential Futures*, the activity gave us a firsthand experience of bringing a first-person future into being.

## A Case Study, Part B: Making Trina

In his account of making, Tim Ingold describes designers and other makers as "participants in amongst a world of active materials ... bringing them together or splitting them apart, synthesising and distilling in anticipation of what might emerge" (Ingold, 2013, p. 21). In this sense, Janet and I might be seen as 'joining forces' in a process that was not entirely under our control. Ingold brings the intractions of making to life in a vivid description of students learning to weave baskets with willow reeds on a beach in Aberdeen. Beginning with tall lengths of willow stuck in a circular pattern in the sand and tied together at the top, the students wove horizontal pieces while kneeling in a cold wind. The baskets that resulted were shaped through a combination of the flexibility of the willow, the length, strength, and dexterity of the students' hands and arms, their tolerance for

the weather, and the direction of the wind, *in correspondence with* — not determined by — the students' own intentions (Ingold, 2013, pp. 22–23).

*Trina* similarly emerged from our designerly and authorly negotiations with a “field of forces,” resulting in a holistic assemblage of biographies, infrastructures, economic and social configurations, environmental conditions, technology concepts, and nascent practices that would be difficult to divide discretely into the prototypes, storyworld, characters, and plot that comprise (design) fictions. We were performing what Ingold calls the “art of inquiry,” in which:

*“the conduct of thought goes along with, and continually answers to, the fluxes and flows of the materials with which we work. These materials think in us, as we think through them. Here, every work is an experiment: not in the natural scientific sense of testing a preconceived hypothesis, or of engineering a confrontation between ideas ‘in the head’ and facts ‘on the ground’, but in the sense of prising an opening and following where it leads. You try things out and see what happens. Thus the art of inquiry moves forward in real time, along with the lives of those who are touched by it, and with the world to which both it and they belong” (Ingold, 2013, pp. 6–7).*

Janet and I collaborated on the story one section at a time, entirely over email. I would send her notes, she would return bits of backstory and a narrative outline. From these I would develop sequential imagery, flesh out the prototypes and how they worked, add more historical research, and put all the pieces together, modifying according to the demands of the story as it grew. I would send a composed draft back to Janet, she would modify it, return it, and the cycle would continue.

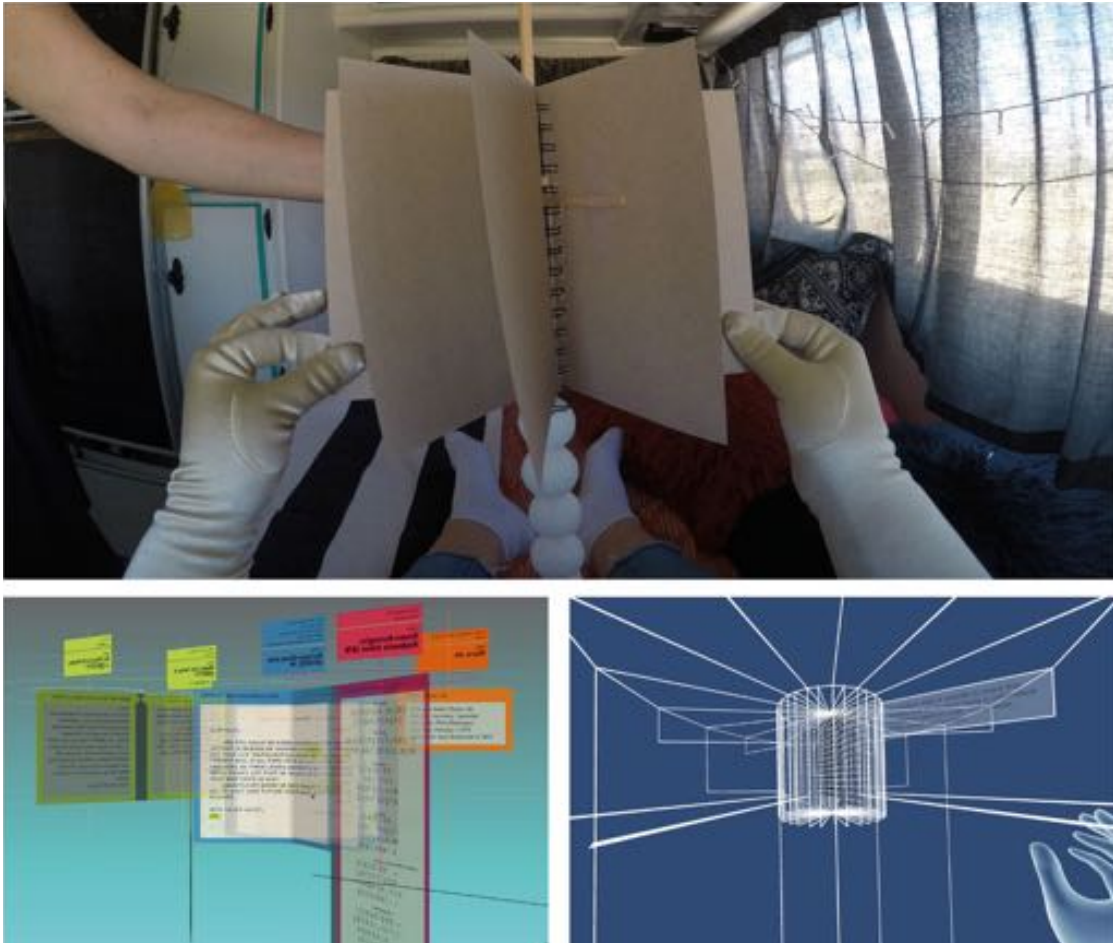

*Figure 3.* Prototypes created during the story's development, clockwise from top: a paper prototype; A VR prototype made in Unity; and a 3-D model made in Rhino

Two years passed between the creation of Part 1 and Parts 2-3. In the interim, the technologies I was imagining were becoming accessible and I had the opportunity to create actual working prototypes to test my ideas for Trina's tech (Figure 3). This allowed me to craft Trina's first-person perspective, to see what she would see when looking with and through the software, because I was able to do so myself. The open-endedness of the collaborative process allowed us to follow new trajectories as they came into view. The openings could come from anywhere in the project: a technological affordance, an animal, a business letter, an artificial intelligence, a newly discovered snippet of history, or from Trina herself.

Through an art of inquiry, in which designing and storytelling were conceived in a dynamic, emergent interplay, an insider's understanding of Trina's future started to emerge. I was weaving together storyworld, prototypes, characters, and plot, and it was getting harder to determine which was which. It is nearly impossible now for me to consider that one could attempt to address any one without implicating each of the others.

So, my next move here will seem counterintuitive, but we will attempt to do just that: temporarily disentangle the components from one another in order to better understand what each contributed to the whole and to explore what kind of access each gives to the human experience of futures.

## Disentangled Storyworlds And Prototypes



Figure 4. Trina's storyworld, from left to right: a neoliberal knowledge economy; a desolate landscape; daily subsistence supported by virtual human intelligence tasks

In their 2015 review of the first ten years of design fiction practice, Lindley and Coulton derive what they claim are the most prevalent components of design fiction in the form of a “definitive definition”:

*“Design fiction is (1) something that creates a story world, (2) has something being prototyped within that story world, (3) does so in order to create a discursive space”<sup>3</sup> (Lindley & Coulton, 2015, p. 210).*

The first component — “something that creates a story world” — gives designers wide berth in regards to narrative: a *storyworld* is not necessarily a story. A storyworld defines the spatial and temporal situation of a narrative, including environmental, social, cultural, political, economic, and other systemic attributes, and should have a degree of internal coherence. In film studies and narrative theory, it is the plot of a story that gives rise to a storyworld in an audience’s mind as they attempt to make sense of what they see and hear (Routledge, p. 569). Though in the case of design fiction, an artefact may be enough to evoke a narrative world of which the object is imagined to be a part (Malpass, 2013).

But storyworlds can also exist on their own. McDowell and von Stackelberg propose creating coherent storyworlds prior to the generation of specific stories in a practice they call worldbuilding in which a world’s attributes — its systems, physical environments, and artefacts — are built by collaborative and interdisciplinary teams. This is not dissimilar to the creation of setting and scenario for Experiential Scenarios, for once created, the worlds can be used as a space for thought experiments and stories to be tried and tested in order to communicate and explore futures. The worldbuilding process allows for the creation of rich narrative worlds as well as insight and foresight in regards to near-future technologies (McDowell & von Stackelberg, 2015).

McDowell shares how he came to the practice through his experience of working in a non-linear process with Stephen Spielberg and others on the film *Minority Report*. In filmmaking, a script is typically written first, then a production designer works with a director to develop the look and feel of the sets and props. But with *Minority Report*, the production design had to begin before the script was ready, resulting in what McDowell describes as a back-and-forth creation of storyworld and

script. The process involved in-depth research into the design of a future world through work with experts from science, technology, urban planning, and other fields, creating a “valuable creative tension” between traditional futurist approaches and storytelling demands. “At three broad scales – the world scale ..., the community scale..., and the individual scale ... – the world begins to fill in with connective rules that develop a holistic logic-driven world space” (Mcdowell & von Stackelberg, 2015, p. 39). As a form of futures practice, the result was not “an individual series of foresights from futurists,” rather it was “an organic evolutionary process centered in storytelling that allowed the emergence of a holistic fictional world that was genuinely precognitive” (Mcdowell & von Stackelberg, 2015, p. 41), a description that resonates with the integrated process that led to *Trina*.

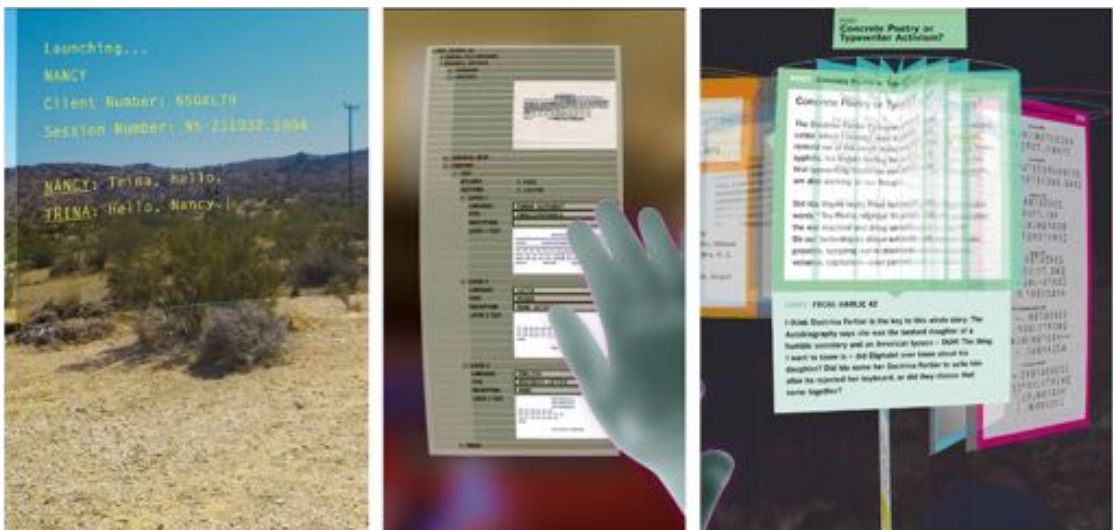

Figure 5. Trina’s diegetic prototypes, from left to right: NANCY, a voice- and text-based AI therapist; Analyst, Humanitas Inc.’s information management app; The Commons, a spatialized text display for networked reading and writing

The second design fiction component — “something being prototyped within that story world” — could be read as a diegetic prototype, arguably the best developed and most unique aspect of design fiction practice. As Kirby reminds us, it is the “visual element that is at the heart of a diegetic prototype” (Kirby, 2010, p. 45). The imagined future technologies of *Minority Report*, particularly Jonathan Underkoffler’s gestural computer interface, serve as one of Kirby’s primary examples of the rhetorical power of a diegetic prototype in which an extraordinary technology is made plausible and even benevolent through its use in ordinary circumstances. But to be convincing, Underkoffler recounts, the prototype needed to be designed as a “self-consistent technological entity” that “adhered not only to the rules of the diegetic world but also to its own internal logic and the constraints of real-world computer technologies” (Kirby, 2010, p. 51).

But not all prototypes are set in filmic contexts. Design fictions are realised in diverse media and many take the form of imaginary artefacts or promotions for future products and services. The narratives can be understood as an effect of the design fiction itself, and are seen as either embedded or external (Malpass, 2013). An embedded narrative is one that is extrapolated from specific attributes of an artefact whose design subverts expectations in a manner that is legible to a viewing audience (the story/world is deduced from clues communicated by the artefact). When an artefact is strange and unfamiliar, an external narrative may need to be conjured through additional media, such as writing or photography, to situate it in a specific use context in order to be understood (the

story/world is derived from an artefact *in situ*) (Malpass, 2013). As enunciative objects, artefacts could also be seen to create subject positions, implicit users who are a kind of human complement to the artefact. In either case, the narrative is conjured in the mind of an interpreter.

Kirby’s concept of diegetic prototypes was informed by the “performative prototypes” identified by Suchman, Trigg, and Blomberg (2002) in the context of Science and Technology Studies. In their ethnomethodological account of information technology development practices in a large corporation — admittedly different conditions for futuring than science fiction filmmaking — they identify how a prototype’s meaning evolves through interactions amongst an assemblage of actors that can include people, a physical environment, management systems, the prototype itself, and more. Placed in a use context, the prototype is a working tool, a mock-up of a proposed future technology produced as part of a design process. The prototype acts as a “tangible, but also provisional, apparatus,” and a “reflexive probe” (Suchman et al., 2002, p. 175). The prototypes of *Trina* operated similarly. Through the design fiction’s holistic creation, I experienced what Suchman et al. observed in their study: “like any technology, the prototype does not work on its own, but as part of a dynamic assemblage of interests, fantasies and practical actions, out of which new socio-material arrangements arise” (Suchman et al., 2002, p. 175).

## Disentangled Characters And Plots

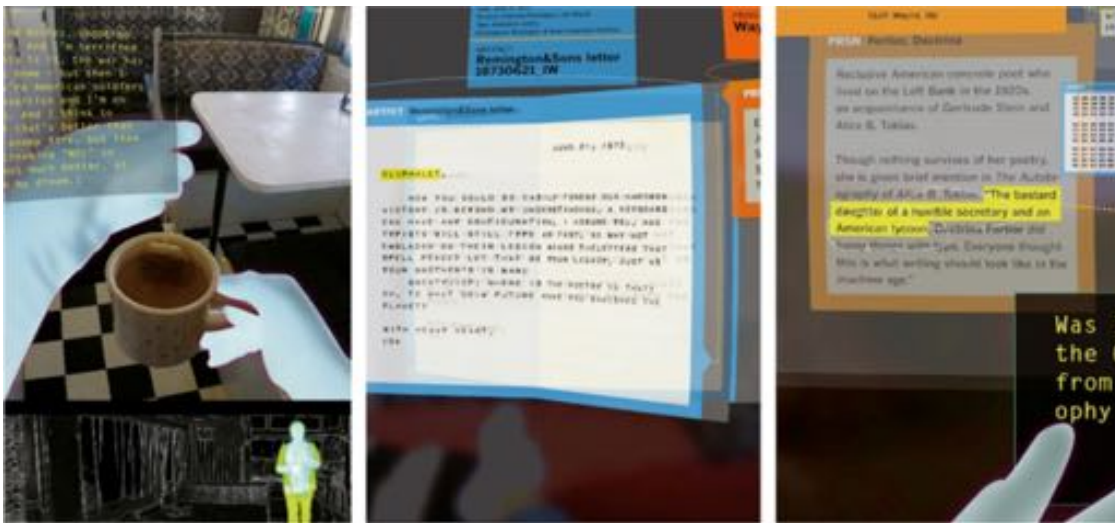

Figure 6. *Trina*’s main characters. from left to right: Trina, an underemployed literary scholar who performs human intelligence tasks (H.I.T.s) to make ends meet; Ida Wayne, a secretary at Remington & Sons in the late 1800s; Doctrina Fortior, a concrete poet who may or may not be Ida’s bastard daughter

The new socio-material arrangements of *Trina* took the form of new practices, shifting our attention away from “discrete, intrinsically meaningful objects” and onto relations and actions (Suchman, 2003). While consideration of the interior individual brings to the scene “the specific ways that stakeholders construct meaning and significance” (Slaughter, 2018), Suchman’s assertion is less centered on the human subject as an autonomous actor and is more concerned with how “relations of human practice and technical artifact become ever more layered and intertwined” (Suchman, 2003, p. 2). This calls for specificity, temporally and spatially: “understanding a given arrangement of humans and artefacts requires locating that configuration within social histories and individual biographies for both persons and things” (Suchman, 2006, p. 284).

Narrative voice is one way to get a distinct inside-out perspective on how relationships are

made meaningful — for both humans and non-humans. In order to project identity, present a point of view by proxy, and articulate subjective and contextualized perspectives, Andrew Morrison has developed a distinct notion of “persona” used to investigate proximal futures (Morrison & Chisin, 2017). In *Wi-Fly*, we meet a rogue female drone, called Adrona, who writes first-person blog entries and poetry that are combined with images and other media to create a multi-modal composite design fiction. Adrona’s misgivings and concerns about her legacy and association with militarized technologies in an urban context are used to interrogate the role of prospective technologies for surveillance in future cities (Morrison, 2014). Morrison was also involved in a set of participatory design fictions about a tiger fish named *Fiscilla*, embodied in a sculptural skeleton that travelled across southern Africa, and a nuclear-powered narwhal named *Narratta* who authored online posts about life in the Anthropocenic arctic. The projects were designed to build ‘futures literacies’ in relation to climate change and the team found that immersing participants in perspectives connected to emotion, cultural identity, the biological, and the conceptual, altered their perceptions and opened them up to new shared meanings (Morrison & Chisin, 2017).

But, as Mark Blythe (2014) points out, “creating a vivid and non-stereotypical character each time a scenario becomes necessary in the design process is a bit of a tall order” (Blythe, 2014, p. 52). Therefore, Blythe and his collaborators created “Pastiche Scenarios” that use personas with the “depth, personality, history and cultural context” of expertly drawn characters from literature and popular fiction, such as Ebenezer Scrooge, Bridget Jones, or Bart Simpson. These characters bring distinctive voices and personal foibles to the imagined “felt-life” experience (McCarthy & Wright, 2005) of a fictitious user. The team’s goal is not to create generic users or use scenarios, rather it is to use idiosyncratic characters for the reflexive engagement they require as established characters that already have “a mind of their own,” one that may be misaligned with a designer’s goals. Pastiche Scenarios exploits the ambiguity that results to explore the emotional, social, and political values related to prospective technologies in imagined futures (Blythe, 2014; Blythe & Wright, 2006).

Social histories and individual biographies exert force on a story. Author Ursula Le Guin (2004) describes composition as “a special condition. While writing, I may yield to my characters, trust them wholly to do and say what is right for the story” (Le Guin, 2004, p. 235). Blythe notes similar comments from Tolstoy and Pushkin who have expressed being surprised by the choices and actions their characters have taken (Blythe & Wright, 2006). “When you construct or reconstruct a world that never existed, a wholly fictional history, the research is of a somewhat different order, but the basic impulse and techniques are the same. You look at what happens and try to see why it happens, you listen to what the people there tell you and watch what they do, you think about it seriously, and you try to tell it honestly, so that the story will have weight and make sense” (Le Guin, 2001, p. X). The story is one amongst the field of forces. And it is these exchanges and transformations, amongst storyworld, prototypes, and characters, that constitute the events of a plot.

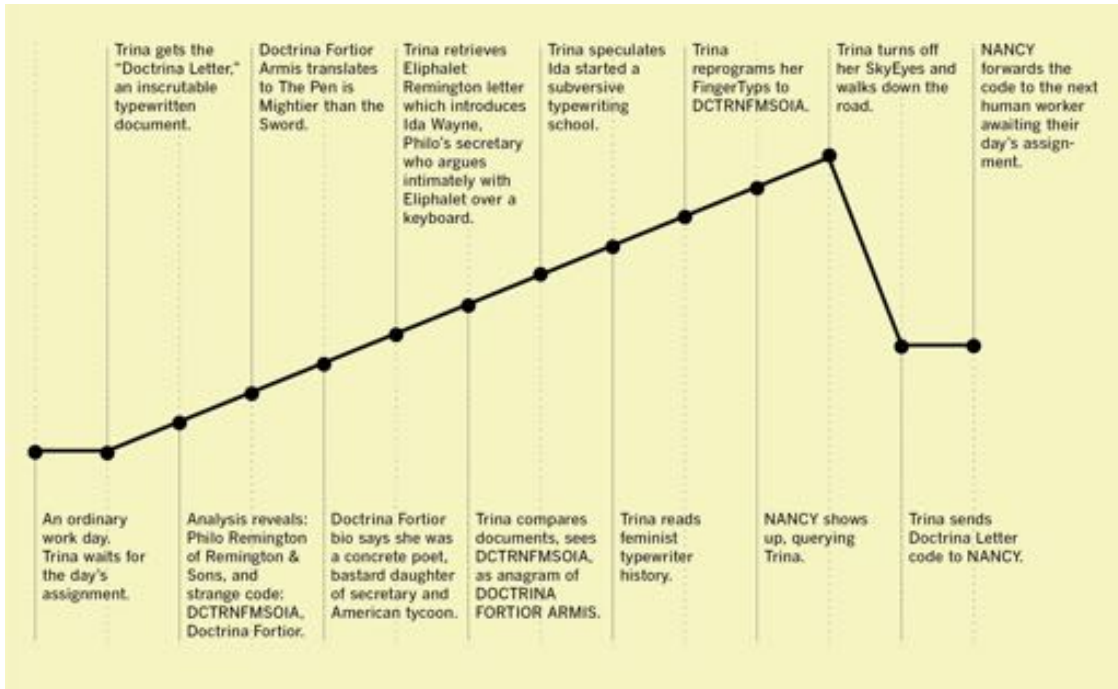

Figure 7. The plot of *Trina* as the arrangement of people, things, and events as they unfold in the telling

Design practitioners who rely upon Sterling’s 2012 assertion that design fiction “tells worlds rather than stories” (Bosch, 2012)<sup>4</sup>, (RTD Conference, Coulton, Lindley, Sturdee, & Stead, 2017) risk missing an important dimension of sociological and technological futures: the new practices that concern Suchman and the consequences that Kirby champions. To get at the messy subjectivity and embodied specificity of people in action, especially when they are meant to be someone other than one’s self, we can return to the literary figuring of narrative fiction which brings the diegetic prototype into use by specific people. Imagining what happens when individuals make moves helps us to contemplate more than just a set of objects and conditions and asks us to consider: in such a world and with such prototypes, *what will happen? What will people do and what new conditions will their choices give rise to?* The answer, of course, depends on the particular people in their particular conditions, or as Le Guin says, “you listen to what the people there tell you.”

It may be helpful here to return to the notion of *diegesis*, which is similar to literary theory’s definition of *plot* — the arrangement of people, things, and events as they unfold in a narrative’s telling. As we learned earlier, it is the plot that gives rise to a *storyworld* in a reader’s mind. Narrative theory also asserts that the plot shapes the story, which in theoretical terms takes place in the space and time of a storyworld and functions according to a coherent chronology and logic (Eagleton, 2008). To illustrate the distinction between story and plot, we can look at a typical detective fiction: the *plot* begins with the discovery of a body then jumps back in time to the events that led to the murder then jumps forward to the trial. Along the way we glimpse clues, fragments from a crime scene or eyewitness accounts that create a partial, composite version (or versions) of the events. The *story*, on the other hand, takes place chronologically: first, a murder happened, then it was discovered and investigated, then the criminal was caught, and then he was taken to court. But a simple chronological accounting may be uninteresting and plot plays with time to craft a narrative experience. If the story that emerges for the reader is a function of the plot, the story could be said to be “in the telling.” Thus, *who tells it and how they tell it* has a significant effect on the “world” that emerges.

While it is possible to map the plot of *Trina* to a simple plot diagram (Figure 7), its telling hinges upon moments of conflict, ethical dilemmas, risk-taking, inspiration, curiosity, discovery, and sacrifice. These moments happen as *Trina* takes action, bumping up against systems of power, revealing very human reactions to a designed future, but also reshaping that future through the moves she makes. Thus we could say, that for Futures inquiry, characters and plot can have as much impact, if not more, than storyworlds and prototypes, on the kinds of futures that get imagined.

### The Holistic Assemblage of *Trina*

Attempting to find the edges or autonomous attributes of a narrative-based design fiction's storyworld, prototypes, characters, and plots confirmed what I learned through *Trina*'s making:

- Individual components cannot work on their own. Tension between components can be productive. Boundaries between components can be fugitive.
- A story is shaped by who tells it and how.
- Specific biographies for people and things necessitate seeing a future world through distinct perspectives.
- The meaning of settings and stuff is constructed through actions, practices, and consequences.

To demonstrate, we will quickly revisit *Trina*, only this time within the holistic assemblage of the narrative-based design fiction.

### NANCY: prototype, character, or plot device?



TRINA: ... so maybe it's not that much better, at least not in my dream. What do you make of that, NANCY?

NANCY: What do you make of it, Trina?

TRINA: I don't know, but sometimes I get that feeling in broad daylight too.

NANCY: What feeling?

TRINA: That screaming NO feeling.

NANCY: Sometimes it helps to talk about our feelings, Trina.

TRINA: Doesn't it help to talk about our dreams?



NARRATOR: Suddenly the characters disappeared, replaced by the slow-blinking insistence of NANCY'S cursor. This was an odd hour for NANCY.

NANCY: Good morning Trina.

NARRATOR: Trina typed a response.

In the first draft of *Trina*, NANCY was a human therapist named Marjorie. As the design fiction developed, Marjorie came to feel inconsistent and we determined that an AI therapist would be a better fit. With a different history and biography than Marjorie, NANCY became multiple things as soon as we put her in the story: a technological prototype, a character, and a catalyst for the narrative’s final act. When she first appears to the reader, she is a clumsy liability management tool from corporate HR. But through the plot, it becomes apparent that NANCY is yet another surveillance technique employed by Humanitas, Inc. and by the end of the story, her pleasant queries take on an ominous tone. (Figure 8) Trina interacts with NANCY as only Trina would. At first, she tolerates and ignores, then she toys with, and finally, she actively defies. Along the way, Trina’s experience of NANCY’s “curtain of text that hangs just beyond the brim of her hat,” a “live transcript” that records Trina and NANCY’s inane exchanges, also infects Trina’s dreams: “‘NO!’ Trina shouted, but no sound came out — only text. A transcript dangled in the air between the soldier, the woman and the girl, but it made no difference, nobody saw it but her.” Trina could sense NANCY’s threat to her agency.

**Trina’s final act: prototypes in use or dramatic event?**

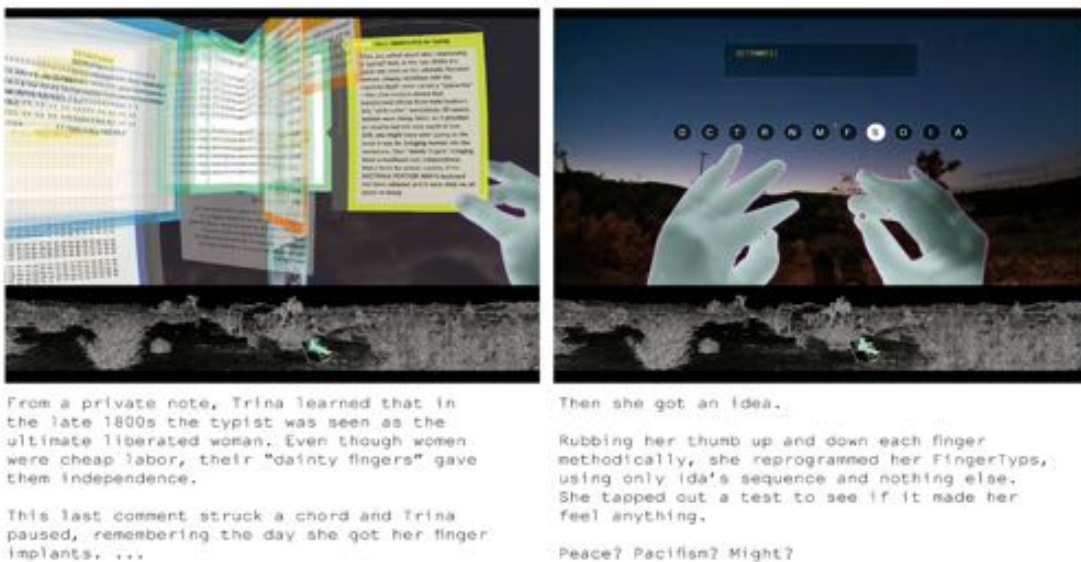

Figure 9. Two scenes that demonstrate prototypes “as part of a dynamic assemblage of interests, fantasies and practical actions, out of which new socio-material arrangements arise” (Suchman et al., 2002, p. 175)

To demonstrate the affordances of The Commons prototype, *Trina* needed to show a reader’s view of multiple simultaneous textual interpretations of a single document (Figure 9). Thus, the plot’s action happens through the prototype’s use: we see Trina manipulating the spindle to read responses to her writing. The responses provide additional clues to the story-within-a-story of Ida Wayne and the gendered history of the typewriter, which Trina interprets through her own subjective lens. Inspired by what she has now pieced together about Ida Wayne — that she tried and failed to encode her pacifist ideals in the keyboard of the first-ever typewriter so she launched a women’s typing school with a subversive teaching method instead — Trina reprograms her own FingerTyps, (another opportunity to demonstrate a future technological affordance). In her final act of resistance, Trina uses NANCY (prototype and character) to send an encoded message that launches a feedback loop with the other human readers of Humanitas, Inc., before unplugging and walking away. The reader of *Trina* is left to imagine what this small army of human readers might do next — as am I.

## Conclusion

This paper has asked how might creating a narrative-based design fiction offer a way for Futures practitioners, design researchers, and technology developers to get a feel for the interior lives and everyday texture of human-scaled futures. We saw how the firsthand experience of creating a first-person future combines the tangibility of design with the interior access of literary fiction, a situation that provides a palpable engagement that can enrich one's futures literacy, particularly when approached as an art of inquiry. But how else might it be used and who is it best used by?

The point of working with an idiosyncratic individual with a specific biography in a specific place and time is not to create generalizable conclusions about functions and uses of technology or to predict human reactions to future conditions. Rather it is to better understand the forces at play that give shape to the action of any world or any story. It is a process best used to explore imagined actions, practices, and consequences that arise in relation to distinct conditions, for example: how technologies might be made meaningful, how agency might be negotiated, how individual motivations might give rise to new practices and social configurations, how people with different biographies and histories might react, and so forth.

But questions remain. How in-depth does the process need to be to achieve its effects? Is it best practiced in groups or alone? Are professional authors and designers necessary? What other forms of disciplinary expertise would be helpful? How open do the process and parameters need to be and where are the limits?

Ingold's art of inquiry helps address issues of agency and emergence through the making of first-person futures. Becoming intimately entangled in a web of materials and forces, human and nonhuman, each pushing and pulling on the action as it advances a story, is the way to achieve surprising and insightful results. As we saw in Ingold's example of weaving a basket, the outcome will be only partially in the creator's control, and the final shape will tell you something about the forces of the world of which it is a part. In practical terms, this means that prototypes, storyworld, characters, and plot should be created in concert with one another and in correspondence with their creators.

As participant-observers, Janet and I did not sit on the outside of our design fiction as it was coming into being; we were an integral part of it. Designing *Trina* was my own experiential future, one in which I could feel the effects of the forces of an imaginary future through the process of making. Working with the specificity of a unique individual and her life at a particular time and in a particular place allowed me to see that while I could have designed a near-perfect technology (the Commons) for Trina, her ability to make use of it was not defined by the (visible) affordances of the designed prototype but by the (invisible) economic, social, political, and ecological forces at play. Seeing a world through Trina's eyes, developing a world in tandem with Trina and Janet and Ida and the RV and the Commons, gave me a first-hand experience of the interdependencies, the fields and forces of a particular future, Trina's complicated everyday. I was a participant-observer, investigating a world from the inside.

## Correspondence

Anne Burdick  
Professor  
Art Center College of Design  
USA  
University of Technology Sydney  
Australia  
E-mail: [anne@anneburdick.com](mailto:anne@anneburdick.com)

## Notes

1. This paper has been created with support from University of Technology Sydney and ArtCenter College of Design, with guidance from Stuart Candy, Molly Wright Steenson, Johanna Drucker, and Daniel Cardoso-Llach, who are on my supervisory committee in the PhD in Design at CMU.
2. The politics of whose lives get imagined, and how, is beyond the scope of this paper but is a key factor that should be explicitly considered by those engaged in this work.
3. As this paper is concerned with the creation of a narrative-based design fiction rather than its outcomes, we will set aside the much-debated notion of opening debate and discursive space, a topic covered elsewhere. (Auger, 2013; Tonkinwise, 2015)
4. In the same interview Sterling responds to the question of what makes design fictions work well: “Talking about a future gadget” which he implies is intrinsically fascinating, in contrast to “talking about a future government or women’s rights in the future or other hot-button problems.”

## References

- Auger, J. (2013). Speculative design: crafting the speculation. *Digital Creativity*, 24(1), 11–35. <https://doi.org/10.1080/14626268.2013.767276>
- Bleecker, J. (2009, March). Design fiction: a short essay on design, science, fact and fiction. *Near Future Laboratory*. Retrieved from [http://drbfw5wfjlxon.cloudfront.net/writing/DesignFiction\\_WebEdition.pdf](http://drbfw5wfjlxon.cloudfront.net/writing/DesignFiction_WebEdition.pdf)
- Blythe, M. A. (2014). Pastiche scenarios. *Interactions*, 51–53.
- Blythe, M. A., & Encinas, E. (2016). The co-ordinates of design fiction: Extrapolation, irony, ambiguity and magic (pp. 345–354). *ACM Press*. <https://doi.org/10.1145/2957276.2957299>
- Blythe, M. A., & Wright, P. C. (2006). Pastiche scenarios: Fiction as a resource for user centred design. *Interacting with Computers*, 18(5), 1139–1164. <https://doi.org/10.1016/j.int-com.2006.02.001>
- Bosch, T. (2012, March 2). Sci-fi writer bruce sterling explains the intriguing new concept of design fiction. *Slate Magazine*. Retrieved from <https://slate.com/technology/2012/03/bruce-sterling-on-design-fictions.html>
- Candy, S. (2010). The futures of everyday life: Politics and the design of experiential scenarios. (Doctoral dissertation). <https://doi.org/10.13140/RG.2.1.1840.0248>
- Candy, S., & Dunagan, J. (2017). Designing an experiential scenario: The people who vanished. *Futures*, 86, 136–153. <https://doi.org/10.1016/j.futures.2016.05.006>
- Dourish, P. (2004). *Where the action is: The foundations of embodied interaction*. Cambridge, Massachusetts; London: The MIT Press.
- Dourish, P., & Bell, G. (2014). *Divining a digital future: Mess and mythology in ubiquitous computing* (Reprint edition). Cambridge, Massachusetts; London: The MIT Press.
- Dunne, A., & Raby, F. (2013). *Speculative everything: design, fiction, and social dreaming* (1st edition). Cambridge, Massachusetts; London: The MIT Press.
- Everyday Futures: About. (n.d.). Retrieved November 28, 2018, from <http://wp.lancs.ac.uk/everydayfutures/>
- Eagleton, T. (2008). *Literary theory, an introduction* (Anniversary Edition). Minneapolis, MN: University of Minnesota Press.
- Fuller, M. (2003). *Behind the blip: Essays on the culture of software*. Brooklyn, NY: Autonomedia.
- Hales, D. (2013). Design fictions an introduction and provisional taxonomy. *Digital Creativity*, 24(1), 1–10. <https://doi.org/10.1080/14626268.2013.769453>
- Ingold, T. (2013). *Making: anthropology, archaeology, art and architecture*. London; New York: Routledge.

- Kirby, D. (2010). The future is now: Diegetic prototypes and the role of popular films in generating real-world technological development. *Social Studies of Science*, 40(1), 41–70. <https://doi.org/10.1177/0306312709338325>
- Kuijer, L., & Spurling, N. (Eds.). (2017). Introduction, everyday futures: a new interdisciplinary area of research. *Interactions*, 24(2), 34–37. <https://doi.org/10.1145/3041276>
- Le Guin, U. K. (2001). *Tales from Earthsea* (1st ed). New York: Harcourt.
- Le Guin, U. K. (2004). *The wave in the mind: Talks and essays on the writer, the reader, and the imagination* (1st ed). Boulder, CO, USA: Shambhala.
- Lindley, J., & Coulton, P. (2015). Back to the future: 10 years of design fiction (pp. 210–211). *ACM Press*. <https://doi.org/10.1145/2783446.2783592>
- Malpass, M. (2013). Between wit and reason: defining associative, speculative, and critical design in practice. *Design and Culture*, 5(3), 333–356. <https://doi.org/10.2752/175470813X13705953612200>
- McCarthy, J., & Wright, P. C. (2005). Putting “felt-life” at the centre of human-computer interaction (HCI). *Cognition Technology and Work*, 7.4, 262–271.
- Mcdowell, A., & von Stackelberg, P. (2015). What in the world? Storyworlds, science fiction, and futures studies. *Journal of Futures Studies*, 20(2), 25–46.
- Morrison, A. (2014). Design prospects: Investigating design fiction via a rogue urban drone. In *Proceedings of DRS2014: design's big debates*. Umeå, Sweden. Retrieved from <http://www.drs2014.org/media/655172/0393-file1.pdf>
- Morrison, A., & Chisin, A. (2017). Design fiction, culture and climate change. Weaving together personas, collaboration and fabulous futures. *The Design Journal*, 20(sup1), S146–S159. <https://doi.org/10.1080/14606925.2017.1352704>
- Coulton, P., Lindley, J., Sturdee, M., & Stead, M. (2017). Design fiction as world building. *RTD Conference*. <https://doi.org/10.6084/m9.figshare.4746964>
- Slaughter, R. (2008). What difference does ‘integral’ make? *Futures*, 40(2), 120–137. <https://doi.org/10.1016/j.futures.2007.11.015>
- Slaughter, R. (2018). Integral futures. *Integral Futures*. Retrieved from <https://integralfutures.com/integral-futures-by-richard-a-slaughter/>
- Sterling, B. (2009). Design fiction. *Interactions*, 16(3), 20–24. <https://doi.org/10.1145/1516016.1516021>
- Sterling, B. (2017). Made up symposium keynote, January 29, 2011. In Mimi Zeiger & Tim Durfee (Eds.), *Made up: design's fictions* (pp. 18–26). Pasadena, CA: Art Center Graduate Press.
- Suchman, L. (2003). *Located accountabilities in technology production*. Centre for Science Studies, Lancaster University, Lancaster LA1 4YN, UK. Retrieved from <http://www.lancaster.ac.uk/fass/resources/sociology-online-papers/papers/suchman-located-accountabilities.pdf>
- Suchman, L. (2006). *Human-machine reconfigurations: plans and situated actions* (2nd edition). New York, NY: Cambridge University Press.
- Suchman, L., Trigg, R., & Blomberg, J. (2002). Working artefacts: ethnomethods of the prototype. *British Journal of Sociology*, 53(2), 163–179. <https://doi.org/10.1080/00071310220133287>
- Tanenbaum, J., Pufal, M., & Tanenbaum, K. (2016). The limits of our imagination: design fiction as a strategy for engaging with dystopian futures (pp. 1–9). *ACM Press*. <https://doi.org/10.1145/2926676.2926687>
- Tonkinwise, C. (2015, March 2). Design fictions about critical design. *Modes of Criticism*. Retrieved from <http://modesofcriticism.org/design-fictions-about-critical-design/>

# How the Future Happens

**James Auger**

**Madeira Interactive Technologies Institute  
Portugal**

**Julian Hanna**

**Madeira Interactive Technologies Institute  
Portugal**

Industrial design, for the most part, is about exploiting the potential of new technologies to create functional, usable and desirable products - design is at the heart of future formation.

Unfortunately, this process is mostly devoid of any critical or philosophical foundation.

Some myths taught at design school:

1. Design is good.
2. Design makes people's lives better.
3. Design solves problems.

Of course design can be and do all of these things, but it has become so intrinsically linked to the prevailing demands of consumption and innovation that it has essentially been reduced to a novelty machine.

Constraints - the rules, forces or beliefs that direct the process - are at the centre of design education and practice. As Charles Eames noted in his *Design Q&A* (1972), design depends largely on "the ability of the designer to recognize as many of the constraints as possible; his willingness and enthusiasm for working within these constraints. Constraints of price, of size, of strength, of balance, of surface, of time, and so forth."

But there are grander, more systemic and pervasive constraints at play. Though often invisible or hidden these factors have a significant narrowing impact on the potential of design, resulting in a paucity of original thinking and a chronic neglect of responsibility.

Here we explore some of the most problematic constraints and the ways in which they influence and narrow the pathways to all of our possible futures.<sup>1</sup>

## **Progress Dogma**

Progress dogma is unquestioned faith in technology, practiced by those with the power to shape the future. For these dogmatists optimism is endemic, meaning that it has become unnatural to think about the negative implications of (technological) products.

Consumers are programmed to believe that the next generation of a product will be better than the current version - the future, as a consequence, being preferable to the present. Progress dogma keeps us on the current technological trajectory, for better or for worse.

Once we remove the constraints of positive thinking, however, it becomes possible to more realistically apprehend the future in (some of) its complexity, helping us to figure out what to avoid as well as where to aim.

So how can we rethink progress to identify possible implications? How can we disconnect from the utopian mantra and twentieth-century mindset of positivist corporate culture? How do we move toward a more constructive approach?

- Stop assuming that, through technology, the future will be better than the present.<sup>2</sup>
- Do not assume that any of society's problems will be solved by technology alone.
- Do assume that for every benefit a new technology brings there will be unforeseen implications - figure out what these might be before implementing.
- Remember to ask: Progress for whom?
- Remember that progress is easily confused with automation and efficiency.
- Design responsibly - and if your employer doesn't allow this, get a different job.
- Actively start building the future you want, with or without technology.

## Legacies of The Past: Infrastructure and History

We are locked into paths determined by choices made in previous eras, when the world was a much different place. For various reasons these legacies stubbornly persist through time, constraining future possibilities and blinkering us from alternative ways of thinking.<sup>3</sup>

Energy is a prime example. Nikola Tesla's invention of alternating current became the dominant approach essentially because it allowed electricity, generated at power stations, to travel long distances. Tesla's system has, for the most part, been adopted across the world - an enormous network of stations, cables, pylons, and transformers, with electrical power arriving in our homes through sockets in the wall. This system dictates or influences almost everything energy related, and in complex ways: from the development of new energy generation methods (and figuring out how to feed that energy into the grid) to the design of any electrical product.

There are ways to counter these constraints:

- Don't assume that the current system is optimal - there are vested interests operating to retain the status quo. *Challenge* and *transform* them (see e.g. Inayatullah, 2008).
- Avoid the generic solution - create new ecologies and sustainable relationships (see e.g. Ramos & Hillis, 2004, on sustainable infrastructure design).
- Seek out the possibility of bespoke alternatives for specific contexts.
- Take into account terrain, climate, language, local culture and politics, available resources.
- Research history, examine forgotten or obsolete approaches for contemporary potential.
- Make design the medium through which transitional change can occur: from speculation to realisation, passivity to activity, conventions to alternatives, consumption to production.

## Education

In terms of constraints on futures, education is fundamental. Skill sets and thought paths are determined at an early age, shaping and constraining possibilities for entire generations. The replacement of manual tools with digital suites might represent positive progress for a minister or board of education, but this trend has serious implications for the future of material things.

Maslow comes to mind: "It is tempting, if the only tool you have is a hammer, to treat everything as if it were a nail." Today this might be: "Give a child a computer, and everything has to be coded." Or 3D printed. Or laser cut. Or CNC machined.

3D printing holds an enormous amount of potential, including the potential for critical design (e.g. Allahyari & Rourke, 2016), but it should not be the only tool in the box. Deskilling leads to a narrowing of possibilities. The more diverse the tool set (and the skills to use them) the more varied the possible future they build.

- Question what is lost in the rush to digitalisation.
- Reskill rather than deskill.
- Diversify toolset rather than narrowing focus.
- Celebrate the sense of touch (not touch screens).

## Knowledge

Protecting hard-won knowledge is necessary and important - the patent system was developed and implemented for good reasons. But the value of patents comes into question when they hinder preferable futures from happening, when the patents relate to universal challenges like finding sustainable methods for energy generation or better approaches to health care. Knowledge protection should not come at the cost of human comfort or wellbeing.

- Strike a balance between knowledge protection and social responsibility.
- Embrace open source.

## Future Nudge: The Tyranny of Iteration

Comparisons between natural and technological evolution have been made since as far back as Darwin's *On the Origin of Species* (1859). Darwin's revolutionary work inspired philosophers, writers, and anthropologists to suggest that technological artefacts evolve in a manner similar to natural organisms. This essentially means that technological development is unidirectional as new products are simply iterations of their predecessors.

This evolutionary mindset is ideal for the market as it facilitates generational updates and rapid object obsolescence. Product lines become established, bolstering brands and reducing the risks associated with *new* things. But this approach to technological products is problematic from a number of perspectives: it locks consumers into generational purchase cycles, meaning short product life and high expenditure; on a global scale it harms the environment as finite resources are depleted to feed the monster. This does not have to be the way the future happens.

- Step out of product lineages at poignant historical moments to create counterfactual histories (see e.g. Bunzl, 2004). For example, what would today's products look like without digitisation?
- Contemplate genuinely new solutions rather than simply updating old ones.
- Observe iterative change from a god-like perspective to identify negative long-term effects. Use this approach to change your own relationship with products.
- To the consumer - be satisfied with what you have, it's probably fine.

## Means and Ends

In his "device paradigm", the philosopher Albert Borgmann (1987) makes a differentiation between *things* and *devices*. *Things* are inseparable from their context: we engage and interact with them in their worlds; means and ends exist in an unbroken continuum. *Devices*, on the other hand, conceal their contexts through the operation of background machinery. The more advanced the technology, the more invisible the machinery, the more dislocated the end becomes from the means.

The present tendency is that designers and consumers alike obsess over the end - the object of desire - while ignoring the means. Nothing illustrates this dislocation of means and ends better than “smart” products such as the fridge or the driverless car. As objects, these devices still resemble their predecessors - but increasingly the ends are controlled by complex, invisible, multifarious systems and interests.

- Start with the abstract general ends (warmth, shelter, transportation, etc.) and rethink the means unblinkered by current approaches.
- Don’t be blinded by shiny ends, scrutinise the hidden means before acting.
- Work toward truly smart change, rather than iterative products that lock consumers into constrained corporate pathways. (The next smart fridge may not be a fridge, but technology acting to optimise seasonal and local means in a transparent way.)
- Re-involve yourself in the means in order to create more ambitious and satisfying ends.

The fundamental questions asked here relate to the role of design in contemporary life and its responsibility to the future. Design is a fundamental part of a postmodern socio-economic system, inextricably linked to entrenched notions of capitalism and conspicuous consumption. This role constrains the designer - and as a consequence the user of designed things - to the narrow path.

But a different form of design is possible. The “big” constraints described above are not immutable. Once revealed they can be challenged, or countered to facilitate the design of fresh approaches. We should expect design to contribute to the shaping of future narratives and aspirations, instead of merely implementing them. Design must provide imaginative, inclusive and sustainable goals to offset the uninspired visions and colourless futures presented by policy makers and corporations.

## Correspondence

James Auger  
Madeira Interactive Technologies Institute  
Portugal  
E-mail: james.auger@m-iti.org

Julian Hanna  
Madeira Interactive Technologies Institute  
Portugal  
E-mail: julian.hanna@m-iti.org

## Notes

1. Useful here are the concepts of “alternative” and “preferred” futures described by Inayatullah (2008), Dator (2009), and others.
2. For a discussion of pro-innovation bias, see Rogers (1995).
3. These legacies of the past bear some resemblance to the “used futures” described by Inayatullah (2004); ill-fitting and outdated futures that are handed down especially to the developing world, but which also persist as a hindrance to change in the developed world.

## References

- Allahyari, M., & Rourke, D. (2016). *The 3D Additivist Cookbook*. Amsterdam: Institute of Network Cultures.
- Borgmann, A. (1987). *Technology and the Character of Contemporary Life: A Philosophical Inquiry*. University of Chicago Press.
- Bunzl, M. (2004). Counterfactual history: a user's guide. *The American Historical Review*, 109(3), 845-858.
- Dator, J. (2009). Alternative futures at the Manoa School. *Journal of Futures Studies*, 14(2), 1-18.
- Inayatullah, S. (2004). Cities create their futures. *Journal of Futures Studies*, 8(3), 77-81.
- Inayatullah, S. (2008). Six pillars: futures thinking for transforming. *foresight*, 10(1), 4-21.
- Ramos, J., & Hillis, D. (2004). Anticipatory innovation. *Journal of Futures Studies*, 9(2), 19-28.
- Rogers, E. (1995). *Diffusion of Innovations* (4th ed). New York: The Free Press.



# Critical Activism

**Anab Jain**  
**Superflux**  
**UK**  
**University of Applied Arts**  
**Austria**

**Stuart Candy**  
**Carnegie Mellon University**  
**USA**

---

## Abstract

*Anab Jain is co-founder with Jon Ardern of the foresight and design organisation Superflux, based in London. This is the edited transcript of a conversation that took place at the First Futurological Congress in Berlin, hosted by the Dubai Future Foundation, on 20 July 2018.*

**Keywords:** Design Practice, Experiential Futures, Speculative Design.

---

**Stuart Candy:** How do you situate your practice in relation to futures and design?

**Anab Jain:** I think we are situated somewhere in the middle. We have a two-pronged approach. We do foresight and horizon scanning – that big, meta-level stuff – but we simultaneously ground it with material explorations, ethnography, research, prototyping.

Obviously we come from a design/art background more than futures. Our schooling was often about what the implications of a certain technology on society might be. And over the years, we've studied the more traditional futures methods a bit, not quite as much as a futurist would.

**SC:** What do you think you've gained over time from engaging with futures?

**AJ:** I suppose it's also what science fiction writers talk a lot about. We hope that through the lens of the future, we are able to reflect better on the present, on the decisions and the actions we take today, on where we want to be.

And to understand that the future is old. The future is actually ancient. It's not this thing that's going to suddenly happen to us then; it's now. It's really happening all the time. That awareness is what we've found really rewarding.

**SC:** What are some projects or initiatives that you've been involved in that you consider exemplary of your approach?

**AJ:** Our approach has changed a lot. We often used to work around a technology, so we would pick something like quantum computing or optogenetics, and try and understand what its potential is, but also poetic implications that the scientists or the technologists might not have explored.

And we've moved from that to thinking more socially, politically. We're very interested in the implications of living with climate change, so for a recent project, *Mitigation of Shock*, we really wanted to understand how to bring that future that is so abstract around climate change - especially in the Western part of the world - making it real and conceptually visceral, but also not dystopian.

**SC:** So you've been at it...

**AJ:** Nine years.

**SC:** I'm interested in how you imagine the work that you're doing against the backdrop of an increasing number of people operating at this intersection. If there is a "you are here" point on a map of bigger activities going on, where do you locate yourself?

**AJ:** Oh, that's a good question. We keep asking that ourselves.

"Speculative design" has become popular, the term; although we have never actively used that term so far. We are afraid of labelling the work we do within a specific discipline, because for us it's changing all the time, and we want to have the freedom to change. So we just call ourselves designers, or artists even.

Where people are interested in our work, or want to commission us or hire us, they are not thinking about us as speculative designers or critical designers either. They're thinking: "We need to think about the future, but we don't know quite how to make it visceral enough to get people to understand the consequences."

Outside of the world of design, not so many people care whether we call what we do speculative design or not. Some people call us a think tank, some people call us a research unit, some people call us artists.

**SC:** What are you grappling with in relation to these practices at the moment?

**AJ:** Lots! We've gone from being tiny to growing quite a bit, and then, recently decided to consider more carefully where we go next, and stop just producing project after project after project. I think we are trying to understand what meaningful change looks like for us.

We keep getting emails from people, and we know that the work affects people and gets them to think differently, but how can we materialise it without using this language of evaluation and impact and measuring? Because these are not things that can be instantly measured. Something that you've done to provoke people could affect them and get them to think differently after years — but how do we begin to surface that?

I see it as a form of slow critical activism. If our work becomes a catalysing force for people to imagine things they would not have been able to imagine otherwise, that's powerful. But then what? We are at that stage right now.



Figure 1. Image from *Mitigation of Shock* installation at CCCB (2017)

**SC:** It sounds like you’re trying to figure out to what extent “then what?” is a question that you have to answer, or one that you put to the people that you’re reaching with the work.

**AJ:** You’re right. I mean, we see how people receive the work, and we see how it affects them. And then we don’t see anything.

Currently I think our work is moving in two directions: one, with people whose idea of the future we may not agree with personally, but who have a lot of power and influence to affect change at a large scale. Our work (Figure 1) with them focuses on helping them consider broader, unintended consequences by enabling them to think differently and more broadly. Secondly, we work in the public sphere, triggering public imagination.

Organisations who have power and influence and can actually affect decisions around climate change or education, are so outcome driven, that their key question around any futures always seem to zoom in on: What are the outcomes we get, and what’s the impact, how will this affect our strategy?

**SC:** And what do you tell them?

**AJ:** We don’t really have a clear answer. We can say, okay, we did this with the UNDP, and that led to the opening of this completely new department where they’re thinking about alternative financing (Figure 2). Or we did this, where it affected a decision or policy change. Examples are few and far between where there is a clear, linear, obvious trajectory of “impact”.

People want concrete stuff, and the thing is, there isn’t a concrete answer. There isn’t a concrete outcome, to be honest. The outcome is the process by which you will start shifting your thinking.



Figure 2. Image from *Mūtō Labs*, created for FundForum International finance exposition (2016); restaged for UNDP Innovation Summit (2017)

**SC:** What do you think are the most important things for people who are interested in this area of work to be aware of?

**AJ:** One of the questions I always get is, “How do you actually make money, and who are your clients?” and it’s like, it doesn’t seem plausible that we could even be doing work and be paid. We’re not set up to be making profit, but we are alright!

We could earlier this year have gone easily from eight to twenty people. But we realised that scaling in numbers is perhaps the wrong way of thinking about “growth” for our studio, and the scale lies in the nature and ambition of each project, and the way it can influence a decision or change perception. The bespoke nature of our work (Figure 1, Figure 2) means we cannot adopt a cookie cutter approach to our services. No brief is ever the same. And having a flexibility of staff and overheads to support such work is very important. We might have big ambitions, but it’s not dependent on the scale of our practice.

**SC:** So what then does success mean?

**AJ:** It’s funny, you know ten years ago, if you’d asked us, I think we’ve achieved what we set out to do in many ways: to be able to run a successful practice, to align increasingly our interests with paid work, to get recognition for it, to be financially sustainable. We’re kind of there now.

We can now turn down projects that we know are neither going to be well paid nor intellectually stimulating, and we would not have done that before. For all these years, Jon would make websites, I would go into film editing, using our skills, barely taking any salary. All of that has led us to a point where now – to say no is a huge privilege.

For a designer, it’s so tempting to have 20, 30, 40 employees, to become “the office”. It is in the model. I am often asked: “How big are you? How many employees do you have?” And they will actually decide whether to give us work or not based on my answer. So yes, sometimes it’s tempting to scale because scale is seen as a visible sign of success.

**SC:** I really like this unwillingness to settle for an inherited definition of success. Instead it's striving for a certain quality of impact, or a certain kind of cultural presence.

**AJ:** We tried it, and we're both not managers. Well, we do have to now, but we really enjoy the actual craft of storytelling, making, building, designing and all of that. So we want to find a way we can continue our practice.

**SC:** Have you ever done a futures process for your own organisation?

**AJ:** No! We should, shouldn't we?

## **Correspondence**

Anab Jain

Superflux

UK

Professor, Design Investigations University of Applied Arts

Austria

<http://www.superflux.in>

E-mail: [anab@superflux.in](mailto:anab@superflux.in)



# Storytelling Shapes the Future

Alex McDowell

University of Southern California

USA

I started my career in narrative media in 1976, designing albums and music videos for artists like Iggy Pop and the Cure. From 1990 to 2012 I was a production designer in the film industry, working with Steven Spielberg, Terry Gilliam, Tim Burton, David Fincher and others. In 2012 I joined USC as a professor of practice and research. In these past four decades I have worked in cinema, animation, theater, opera, video, graphic and web design, publishing, commercials, music videos, fine art and printmaking. I am now co-founder and creative director of radical design studio *Experimental Design* in Los Angeles, and a professor at USC School of Cinematic Arts where I run a lab, institute and class devoted to worldbuilding.

Worldbuilding is a narrative and systems design practice that exists at the intersection of design, technology and storytelling. For 30 years I've been working in film, and over the years that has made me think deeply about the notion of storytelling.

Storytelling started as a way to make sense of the world around us. The earliest tribal storytellers, as they told their evolving stories around the fire, used metaphor to explain the unknown in terms that their community would understand. They looked at that silver disc crossing the sky and translated it into a story of a princess in a chariot, and these metaphors established the first principles of storytelling. Tribal storytelling not only made sense of the world, but also started creating codes for that world.

Multiple storytellers collaborated to create the great mythologies, which passed from generation to generation to ensure our survival through complex and evolving narratives that represented the DNA of our human survival, our knowledge of the world. These giant mythologies that emerged – the Roman and Greek Sagas, the Bible, the Quran – were the cumulative work of countless storytellers, all adding layers to the narrative.

And then, in 1440, this socially-embedded and adaptive storytelling was massively disrupted by the arrival of the printing press, and the notion of storytelling started to shift. The printing of books allowed religious authority to lock the words and control the content of these stories and their distribution. And gradually the author started to own the story, and its audience. The writer, the composer, the director, the artist, the 'starchitect', the photographer, the designer: for six centuries now, we have become habituated to the idea that we are an audience waiting to be fed. Although this in no way undermines the power of the single-authored narrative (Shakespeare, Picasso, and Mozart), the theatre proscenium, the frame of the screen, the pages of a book all direct us.

We are now entering an era that one could call 'post-cinematic', as we do at the USC School of Cinematic Arts. The tools that have now come upon us – virtual reality, augmented reality, mixed reality – do something more than provide a new gimmick to sell hardware. They demand that we shift away from linear narrative, the fixed or controlled frame, into a new multi-dimensional narrative space. We now need to pay attention to the entire worldspace, the sphere of narrative opportunities around us. But in the process, it begins to look as if we have returned to the tribal narrative, the oral, non-linear, collaborative and evolutionary origins of story. This is as big a disruption as the invention of cinema. It is going to fundamentally change the way we think about storytelling. We now are returning full circle: those tribal stories we were told to help us survive become a

framework again for us to make sense of the unprecedented complexity of the world around us, just as we need them most. (Figure 1).



Figure 1. A Brief History of Storytelling (2019 version), c. Alex McDowell

Worldbuilding as a design practice, which has evolved for me over the past two decades, seems suddenly more and more relevant, because its holistic and collaborative structure specifically supports organic and fluid narratives that are embedded within and driven by the intricate world around us. I was trained, as are most filmmakers, in a factory-line Victorian industrial process that is transforming into this deeply collaborative and nonlinear methodology - like jazz - with the human at the center. This design-driven, media-agnostic, multi-platform capability flips the twentieth century model on its head and paves the way for new story practices ahead.

There are some high-level ecologies that form around the questions one might ask of a storyworld. You start with an origin story - this can be very simple, the first question asked. Then you move onto the contextual questions: *Where are you? When are you?* High level provocations - *What If, Why Not* - ask what is driving the world. Bit by bit, supported by deep research and What If provocations, we create a high-level, horizontal ecology of the world. The more questions you ask of the world, the more narrative details start to emerge, raising questions in themselves. As you 'core-sample' through the world, it becomes more and more robust, at multiple scales (state, region, city, neighborhood, street corner) simultaneously.

Two important things are going on in a worldbuild. First, you are dealing with a massive interdisciplinary collaboration. When you begin research you are listening to domain expertise beyond the knowledge of the design and story teams, and these seeds and pathways start to build infrastructure, resources, socio-politics and culture into the worldsystem being created. Secondly, the worldspace, the larger context, is constantly informed by what is most important - that is, the human story at the center. We start developing personal stories inside the world. These stories question it and push it forward across different scales - the human in the neighborhood, the neighborhood in the city, the city in the world - all inform each other, and the world evolves (Figure 2).

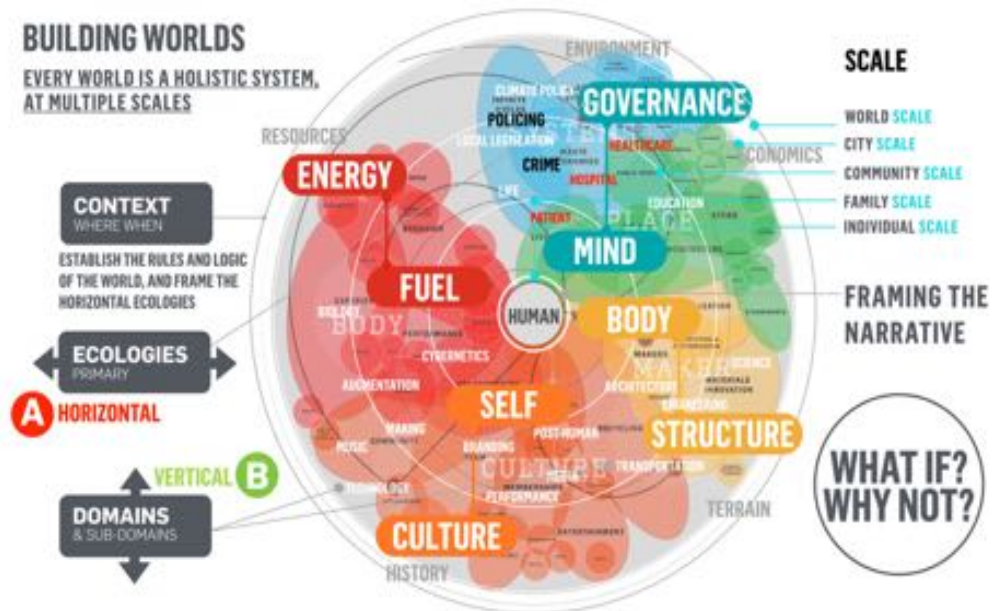

Figure 2. The World Building Mandala © 2018 Alex McDowell

This was really put into practice for me in a film called *Minority Report*.<sup>1</sup> Steven Spielberg hired me as Production Designer on the same day as he hired the writer Scott Frank. There was no script when we began conceiving of the world of *Minority Report*, and we didn't have a complete script for a year. Significantly in this case, the design of the world *preceded* the telling of the story. The world had become a container for narrative – not just one narrative, we could have told hundreds of stories in this space. We knew the world intimately (Figure 3). If Steven Spielberg had wanted Tom Cruise to turn left instead of right out of any doorway, we knew what was there. And it was clear that you could apply completely different lenses to the world developed for the film. Although our work supported a linear cinematic narrative, it could also have been used as a way of looking into the future of urban planning; targeted advertising; wearables; gesture-based interfaces; autonomous mobility, many diverse aspects of the world (Von Stackelberg & McDowell, 2015).

A kind of real-time, nonlinear process evolved throughout the production of this film, which tested not only how one might think differently about film production, but also how to think differently about developing a story. For the first time there were digital sets and design visualization allowing the director's interaction with the film environment and digital characters long before shooting. What was also significant was that scenes emerged from the development of the world that would not have been in a script written in advance of production by a writer sitting in a bungalow in the Hollywood Hills and typing out 120 pages. The world had incepted the narrative in a really fundamental way. The fabric of the world had triggered the story.



Figure 3. *Minority Report's* Vertical City in Washington DC, 2054 © Alex McDowell

Over the years since it was released, there has been a constant stream of innovations that could be directly tied back to the film (Liptak, 2012). These include developments in bio-mimicry, driverless cars and drones, as well as the gesture system that John Underkoffler, our in-house scientist in the art department, developed as part of his research at MIT Media Lab.

We began to notice that worldbuilding could be used to stimulate really complex systems, quite separately from the narrative, an aspect that defines much of the research and outcome of our current and evolving work. Any world is an interlocking system, driven by a rigorous methodology and logic. We investigate all the possible societal, technological, economic, environmental, and political influences on a given world. As a result, multiple stories – provocative, inviting and immersive – begin to grow rapidly and organically from the systems of a world.

I'd like to give you a brief introduction to four of the projects we have worked on that use worldbuilding techniques to develop sustainable solutions to real-world problems.

First, the early stages of a project developed for the legendary oceanographer Sylvia Earle, called *The Future of the Ocean*. The starting point for this project is that the ocean is impenetrable: those of us who live by it mostly see the surface; those of us who dive in, dive down 30 feet or 100 feet, but the vast bulk of the ocean is unexplored. How do you allow people to enter that worldspace? Imagine a giant column of water in a museum, being projected virtually. The column expands towards you, its surface passes by your field of view, and suddenly you're inside the depths of the ocean (Figure 4). You hear sound overhead, look up, and see the massive propellers of a ship on the surface, and you understand the effect of noise pollution on fish. You look down to the coral and see the effects of acidification. You can move back and forward in time and see what the coral used to be, what it is now, and what it could be again. You go deeper still, and change scale, and get down to the level of plankton. Virtual reality gives us a level of access and completely compelling immersion that change space, time and scale.



Figure 4. 'Pre-vis' from the Future of the Ocean project, Sylvia Earle and Experimental Design studio

Second, we have been working with a foundation in Saudi Arabia on a housing and sustainability development project called *Al Baydha*.<sup>2</sup> We were asked to look ten years into the future of a specific Bedouin tribe, a nomadic tribe who had been settled and fallen into abject poverty, with failing crops and decaying shelter. We were asked to create digital and design visualisations that would allow members of this community to look 10 years into their own future, and to own it. It allowed them to see alternative choices for their people - from sustainable housing to permaculture that establishes new and robust crops, are all being implemented in the real world (Figure 5).



Figure 5. *Al Baydha Village* project by Experimental Design studio

Third, we have worked in collaboration with Situation Lab - building on their imagination game *The Thing from The Future* - to create a website for the Cook Inlet Tribal Council, who were

deeply engaged in connecting the Alaska Native Youth to their millennia-old culture of innovation. In the vision developed for the interactive story space, narratives speak of the next 20 years, and the innovations achieved in the future by indigenous youth.

Finally, with the World Building Media Lab that I run at USC, we staged *Leviathan* (Figure 6) - an augmented reality experience of an 80-foot whale flying over 5000 people at the Consumer Electronics Show, CES.<sup>3</sup> The next phase of this fantastical world took the project to the Sundance Film Festival. The augmented reality whale developed into a full virtual reality immersive and interactive laboratory experience, set in a parallel universe in 1896. Within this environment, you are a visiting scientist to the lab. First, on 'rails', you approach the structure slung beneath the massive whale, without agency. As you enter the Lab you are instructed to go through a series of tasks to create a hybrid flying creature. As you reach out in the virtual world to touch a virtual object, you feel physical objects aligned exactly with the virtual, a haptic experience. The cause-and-effect series of actions creates a flying creature that you begin to interact with in real time. And then the creature decides to exchange bodies, and you begin to fly up in the air until you can see yourself far below. In five minutes, the user has experienced a magical set of interactions that fully exploit the possibilities of a non-linear, organic and fueled narratives that could not have been told in the western world for the past 600 years. *The story of Leviathan* offers a self-contained ecosystem, a completely fantastical world in which we can develop multiple intricately woven threads, and use this fictional space to discover new ways to tell stories for the future.



Figure 6. *Leviathan* project by Experimental Design studio and World Building Media Lab USC

As designers and storytellers, we are faced with incredible possibilities now and just over the horizon, and we are just scratching the surface of what storytelling can do. Worldbuilding is about collaborating across art and science. The next generation I see emerging – through the students and teams with whom I am fortunate to collaborate – are taking on the role of art-scientists. They are turning storytelling into a new form, one that can powerfully change the world.

## Correspondence

Alex McDowell  
University of Southern California  
Los Angeles  
USA  
E-mail: alexmcdowell1@mac.com

## Notes

1. <https://experimental.design/portfolio/minority-report/>
2. <https://experimental.design/project/al-baydha/>
3. <https://experimental.design/project/leviathan/>

## References

- Liptak, A. (2012, June 21). *Minority Report* really did predict the future. *io9*, <https://io9.gizmodo.com/minority-report-really-did-predict-the-future-5920302>
- Von Stackelberg, P., & McDowell, A. (2015). What in the world? Storyworlds, science fiction, and futures studies. *Journal of Futures Studies*, 20(2), 25–46



# I Design Worlds

Liam Young

SCI-Arc

USA

Stuart Candy

Carnegie Mellon University

USA

---

## Abstract

*Liam Young is an Australian born architect currently running the MA in Fiction and Entertainment at Southern California Institute of Architecture in Los Angeles. This is the edited transcript of a conversation that took place at the First Futurological Congress in Berlin, hosted by the Dubai Future Foundation, on 22 July 2018.*

**Keywords:** Architecture, Design Futures, Experiential Futures, Film, Worldbuilding.

---

**Stuart Candy:** How would you describe your practice in relation to the intersection of futures and design?

**Liam Young:** I'm trained as an architect, so I am interested in the architectural, urban and global implications of emerging technologies. I don't design buildings but rather I design, imagine, speculate, and construct worlds. The world is the medium in which I prototype futures. It's a very spatial way of thinking about future narratives. I predominantly explore these worlds through the medium of film. For me films are a way of disseminating these worlds to audiences.

So that's where my own practice sits in the context of design/futures practices. It differentiates itself by thinking about worlds as the medium of operating, as opposed to products, characters, buildings, and so on.

**SC:** How standard or non-standard is that, to be an architect thinking in terms of a world rather than a building?

**LY:** For the most part architects think in terms of buildings as singular objects on a site, but in many ways, we are trained to think through worlds. I think it's the great disappointment of architecture that most architects waste their time just designing buildings. The skillset is far broader than that. We used to think about forms of design research, curation or speculation as being work on the margins of the discipline, but really we are now at a point where the architects making a living from boutique craft buildings are the ones increasingly marginalised. The physical fabric of a building is now just one element of our experience of cities or spaces.

So most traditional architects don't do futures, but I think it's a very easy transition for them. Architecture is really about telling stories in space, and being able to imagine how that space might evolve across time. And

that's why I still call myself an architect, because I think I'm still practising architecture, or at least a form of architectural thinking.

**SC:** I appreciate this notion of architecture having a native territory that it doesn't necessarily realise is so core to what it does.

**LY:** When Dunne and Raby expanded on speculative design and non-functioning prototypes it was quite revolutionary. There wasn't really a significant tradition of speculative objects within product design before they started working. Whereas within architecture, because so much capital is wrapped up in the production of a building, there's always been an important practice of speculation at architectural and urban scales. It has often been a way to explore and disseminate ideas free from the weight of construction budgets.

**SC:** How would you situate your interests in the wider landscape of design and futures, this intersection much explored, and dabbled in, over the last decade?

**LY:** I'm interested in moving outside of that territory of the design-futures nexus, and in co-opting, not forms of design media, but forms of popular media, and encoding within them these critical questions about what the future means.

I have previously made a lot of work for the design futures circuit. There's certain galleries that show that type of work; there's certain platforms, festivals and conferences that help produce and fund the work we have produced.

But to a certain extent it's an echo chamber. If we really value what we do in futures, and we think it's important, we should be thinking much wider than the design futures market. For me, that was about working with popular mediums that we typically dismiss as being lowbrow or mainstream pulp, such as film, video games and TV.

So part of my move to LA was to parasitically operate within the mechanisms of the entertainment industry. I think of critical ideas as Trojan horses, sited within the medium of a Hollywood blockbuster, or a Netflix series. This is where the practice is sitting right now.

In the context of futures, the scale of change required to engage meaningfully with issues such as climate change, economic disparity, the automation of labour, shouldn't just end in single speculative design projects that sit in a gallery somewhere in Berlin. The change necessarily occurs through paradigm shifts. It changes through big cultural moves. And that is about instilling within forms of popular culture a different way of thinking about the world. It involves engaging large-scale public audiences in those conversations.

You can seed really powerful ideas about futures in these mediums: everyone watches film. It can be this extraordinary vessel to carry important ideas about who we are and who want to be. It's our duty, I think, generationally, to seed these cultural mediums with ideas that we think are important, so that people can start to engage with them. I think that's a real critical role that the architect, speculative designer or futures thinker can play.

**SC:** A brief example of a project you've done that leans into this space you're sketching out?

**LY:** Working with author Tim Maughan I made the short film *Where the City Can't See* (Figure 1). It's the first narrative film made entirely with LIDAR scanners, the surveillance system that driverless cars use to read and understand the world. It's a system of machine vision that transcends traditional photography and creates three-dimensional models of the world. It's a form of mapping and calculating the world with extraordinary opportunities for efficiencies and infrastructure, and at the same time it comes with significant questions around issues of privacy, responsibility and surveillance. We are interested in what it means to literally have constructed a millimetre-precise virtual model of the entire world.

So we made a film as a vehicle to explore what it might mean to live and operate within the context of a city that can see everything. Where do the spaces of exception exist in this form of city? What is the equivalent of a warehouse rave, a wilderness zone, a site of transgression? What does it mean to be a member of a subculture in a city of ubiquitous surveillance? We developed a

working prototype for a new kind of hoodie that disguises the body from these scans. It creates a form of digital camouflage or glitch that allows the wearer to disappear to the eyes of the machine. We worked with a choreographer to develop a vocabulary of dance movements that would disguise the proportions of the body to the systems of body detection algorithms. And these ideas aren't just a story or a plot point, they are working prototypes that happen to be sited in the medium of film.

**SC:** You emphasise that this is something that works. How important is the feasibility of the prototyping?

**LY:** I'm interested in a level of believability, or realism, which makes the narrative, the story, the prop, feel urgent or visceral or inescapable.



Figure 1. Still from *Where the City Can't See* (2016)

**SC:** Believability is about perception. Making it seem real doesn't require that it be real on closer inspection.

**LY:** True, but making it real-real is one reliable way of engendering that level of believability or empathy. For it to be plausible and create an emotional engagement, I think is the most important thing at the core of all this. But we like to work with the technology in very real ways because it gives us another way that we can disseminate the world we've designed.

A whole raft of press was produced around *Where the City Can't See* totally independent from the nature of the film itself. We were on Gizmodo, on BBC, all these places, talking about digital camouflage. Then it hit the film festival circuit and had another kind of cycle, separate from the props within it, based on the storyline and the visuals. It just allows it to operate in a whole range of different contexts, and connect to a broad range of different audiences.

**SC:** Technological realism or feasibility is a higher bar of a sort, also limiting how speculative you can be. Tell me about that trade-off for you.

**LY:** I don't want to go into the realms of fantasy. With my speculative work I want to be in that sweet spot between not here yet, but not far enough away that it can be dismissed as pure fantasy.

**SC:** Being on the crest of a wave that's going to break no matter what is more powerful in some ways, but if worlds are the medium, and they are what's at stake, we need enough lead time to make a sort of societal choice between those worlds. There are limits to the usefulness a speculation can

provide when it's on the verge of happening regardless of whether or not you do the project.

**LY:** Yeah, it's not exclusively the space in the spectrum where I would operate, but it's a place that I think personally I can contribute to the most to because of my training. What architects can do quite well is synthesise technology and culture. It's one of the very few disciplines where you have classes in engineering and coding, but you also have classes in philosophy and critical theory.

What we do with these types of projects is engage with the technology at the point where I think it's most interesting, which is often the point where it becomes democratised or widely accessible. Tim and I talk about this great quote from science fiction author William Gibson, "The street finds its own uses for things." Technology becomes interesting when it hits the street and moves outside the dominant discourse into a subcultural space. We like to take that leap and prototype the new forms of culture that these technologies produce.

It's not exclusive. It's not to say that this is the best space or only space where speculation works. It's just that these technologies, before culture technologies as I describe them, have arrived before our cultural or ideological capacity to understand them. I think a film like *Where the City Can't See* or one of our other projects *In the Robot Skies* (Figure 2) are really important to make right now.



Figure 2. Still from *In the Robot Skies* (2016)

**SC:** I agree with you, and I think that need exists partly because the longer-range speculation hasn't happened either. We're talking about layers of under-served futures discourse.

**LY:** That's exactly right. In the context of driverless cars, these things are happening. Ford, GM, all these companies are already billions of dollars in. Now we're making films about driverless cars because we know they're coming, and we want to be prototyping cultural and ideological positions around their imminent arrival. But I would have much preferred to have been in the room 20 years ago at Ford: "Let's do some forecasting here, let's prototype some stuff, let's see if this is a good idea first."

Now you can't walk into an architecture school anywhere in the world without seeing a driverless car studio, where they're thinking about what it means for urban life, what it means for the street. Architects should have been doing that 15 years ago.

**SC:** Architects, designers, policymakers...

**LY:** Everyone.

**SC:** You quoted Gibson a minute ago. He also famously said, “The future is already here, it’s just not evenly distributed.” The present, the future coming into being, is a process. There are stages; before the trend, the emerging issue; it’s over the horizon, and then little by little, becomes a kind of imminence. So there is a spectrum of places to intervene in the onrush of potential. What you’re doing is closer in, and that needs to happen. Meanwhile the futures field generally probes further-out possibilities and time horizons, which are traditionally underexamined even in areas like design and policy. I’m interested in how the whole range of design and media practices can make these things feel real enough to bother to have the discussion before you *have to* have the discussion. Because with longer lead times, larger world-shaping choices are available.

**LY:** Yeah, exactly. All these types of projects need to happen, basically.

Drones felt important to work with. To work with that emerging tech felt like an urgent thing to do. I don’t do a lot of drone work anymore, but our first exploration of the tech, the project Electronic Countermeasures was done before there was any thought of drone regulations. We were flying them in a festival in the Netherlands where they were drifting above people’s heads, in public spaces. And you would get arrested in a heartbeat doing that now. In just a few years that space has changed so much. Now the debate has become mainstream after the disruption they are causing at airports.

**SC:** So how did that project play out in terms of its influence on the policy discussion, on the public capacity to respond?

**LY:** This is the point we’re at with a lot of this speculative design — developing the metrics through which we can judge the influence of these things. Where did it go? I don’t know. What we were trying to do was shift the conversation about drones into a more cultural space. And I think we are now there, not just because of these films, obviously, but we’re now talking about drones in a whole range of ways.

**SC:** So for futurists interested in design, designers interested in futures, what lessons are there to be shared from the intersection?

**LY:** I think that in this space we have to be talking about audiences for the work. Design and futures now has a large enough global circuit that you can have a reasonable career drifting and hovering within that circuit, right?

**SC:** Like a drone?

**LY:** Ha! To really think about where our projects land is fundamental to the act of producing them. Let’s not be design futurists, let’s operate as design futurists within policy, within government, within academia, within Hollywood, within the video game industry, within infrastructure. I think that’s a real key for me.

Design futures is a practice, not a discipline. Its greatest strength is not siloing it as a thing that’s legitimate in itself, but looking at it as a methodology that can find traction in a whole range of different disciplines outside of itself. And I think that’s where we’re at with it right now.

## Correspondence

Liam Young  
Southern California Institute of Architecture  
USA  
<http://www.tomorrowsthoughtstoday.com>  
E-mail: [l.young@tomorrowsthoughtstoday.com](mailto:l.young@tomorrowsthoughtstoday.com)



# Anticipating Future System States

Jamer Hunt  
The New School  
USA

The profession of design is undergoing a paradigmatic shift away from the design of artifacts as solutions to problems. Instead, we are now starting to see these problems themselves as the symptoms of dysfunctional, larger macro-systems that are themselves shaping the problem space.

In her foundational book *Thinking in Systems*, Donella Meadows illustrates for us the basic building blocks of systems. She writes, “A system is a set of things—people, cells, molecules, or whatever—interconnected in such a way that they produce their own pattern of behavior over time” (Meadows, 2008, p. 2). In her formulation, a system is not simply a random gathering of parts (like snowflakes on the sidewalk); in its unfolding its structure must demonstrate some higher level of order or purpose.

This is, perhaps, the most bedeviling characteristic of systems: the purpose cannot necessarily be derived from the elements. A droplet of rain does not communicate that it plays a central role in thermal regulation of climate or in the transpiration necessary to make plants grow. That system we must intuit from a point outside of the raindrop.

Systems do not exist; we posit them. This is their second bedeviling characteristic. This means that systems are political, first and foremost. To constitute a system one must make exclusions and draw boundaries. What is included, what is not, and who is doing the deciding all imply a politics of boundary and set determination that is little different from the cartographer’s drawing of territorial borderlines. The system-maker must constitute boundaries and edges and insides and outsides and elements and nodes and connections in order to circumscribe the contours of a system. We might all agree that textbooks are a part of the education system, for instance, but would we all agree that a nutritious breakfast is? Or domestic disharmony? Put differently, the ontological status of a system is always provisional and motivated. A system does not exist until we claim that it is one.

Two points are central here: first, there are no systems per se. Systems are constructs or assays that actors devise to shape reality in particular ways and for particular ends. As Meadows writes, “There is no single, legitimate boundary to draw around a system” (Meadows, 2008, p. 97). Second, to constitute a system we must stand at some Archimedean point outside of it, and yet there is no such standpoint that allows us to fully grasp a system that does not, in some way, include us (as the shaper of that system). As with the Heisenberg uncertainty principle, our presence as system-boundary-makers ineluctably redraws the system according to our own, distorting sightlines.

While we may speak about redesigning public education or food systems or politics, it is simply impossible for designers or other actors alone to influence in any deterministic way the complex systems they see misbehaving. Counter-intuitively, intentional fixes to dysfunctional systems often produce results that would be worse than doing nothing. For example, one of the most assured ways to increase traffic congestion is to add more lanes for cars—as this only incentivizes more people to commute, worsening the problem. Horst Rittel and Melvin Webber, in their famous essay on the blind spots of modern planning, see this quandary as defining what they term “wicked problems” (Rittel & Webber, 1973).

Designing for systems is, in fact, radically different than designing artifacts. An artifact condenses and freezes a set of relations into a state of being, utilizing scripted physical cues to choreograph a user’s behaviors

towards a set of predetermined, target actions. Hold here. Turn there. Power-up over here. Sit there. Read like this. Look here. Enter there. Even service design, with its complex constellation of actors, behaviors, scripts, and spaces circumscribe a bounded set of possibilities, with the service blueprint serving as the template. The design artifact forecloses possibilities—though not in a pejorative sense. It is the instantiation of an instrumental objective enabled by the subtle reconfiguration of a set of physical or processual affordances.

Systems, on the other hand, are comprised of elements, relations, connections, and flows that together demonstrate macro-level behaviors. Whereas the traditional products of design are configurations of matter in a state of being (finished, bounded, and knowable), the design for systems must instead open up a space of becoming—partial, indeterminate, and open. The aim is not to resolve a system—to fix it into a forever-ideal state—but to model the possibilities that system interventions might provoke.

In terms of how one intervenes into systems, Donella Meadows lyrically writes, “The future cannot be predicted, but it can be envisioned and brought lovingly into being. Systems cannot be controlled, but they can be designed and re-designed” (Meadows, 2008, p. 169). Rittel and Webber reach a nearly identical formulation, “Social problems are never solved. At best they are re-solved—over and over again” (Rittel & Webber, 1973, p. 160). Both statements reveal a hard-earned truth of wrangling with systems: the best a designer can do is to envision or model possible future system states...how they may come into being and how they might evolve over time.

Even though systems do not “exist” and are unruly, that does not mean that we cannot develop strategies for materializing their presence and modeling their behavior in an intentional way. We codify and model immaterial abstractions in a variety of disciplinary domains: urban planning, quantum physics, medical diagnoses. In each of these cases we conceptualize possible system states to explore the symptoms of systemic dysfunction, even though we may not be able to clearly identify the root cause. If the ultimate aim of systems design is to perturb socio-technical systems so that they manifest new, more desired behaviors, because of their complexity there is little guarantee that any change will yield the desired results.

Envisioning future system states requires designers to adopt the strategies of anticipation, speculation, modeling, and prefiguring the unknown. US Secretary of Defense Donald Rumsfeld, of all people, surprisingly captured the contours of this challenge while speaking about military planning in the aftermath of the September 11 terrorist attacks. Bemoaning the radical indeterminacy of the counter-insurgency efforts, Rumsfeld pontificated, “as we know, there are known knowns; there are things we know we know. We also know there are known unknowns; that is to say we know there are some things we do not know. But there are also unknown unknowns—the ones we don’t know we don’t know” (Rumsfeld, 2002). Designing artifacts brings us into the realm of the known unknowns—will the vacuum cleaner be lifted from this point or from that? Will the reader plunge in all the way into the information or only skim the headlines? Is the staircase designed invitingly enough to encourage occupants to walk rather than take the elevator? In designing for complex systems, however, we are in the Rumsfeldian realm of the unknown unknowns. We don’t even know and cannot even anticipate what an intervention into a system might produce. It presents a particularly knotty problem.

Recently, in my collaborative studio teaching, we have begun to experiment with ways of designing for future system states, deploying a variety of strategies in an attempt to model the unknown unknowns.<sup>1</sup> Because systems are immaterial and abstract (though still comprised in part by material elements), we have taken to using video as means of modeling the human behaviors that perturbed systems might generate. Human behavior is an index of system behavior, because systems are abstractions made manifest by the behaviors of human and non-human actors. Rather than simply contrasting diagrams of existing and modified systems—before design and after—we use speculative, future scenarios to explore the unknown unknowns. Anthony Dunne and Fiona

Raby, pioneers in the practice of speculative and critical design, suggest that, “Although operating at a systemic scale, large-scale speculative thinking...contests ‘official reality’...it aims to be inspirational, infectious, and catalytic...blurring distinctions between the ‘real’ real and ‘unreal’ real (Dunne & Raby, 2013, p. 160).” Working in this speculative systems space, *Landfull* (a studio project Colleen Doyle, Ashley Graham, and Chisun Rees)<sup>2</sup>, for instance, considers what our world might look like and what role objects may take on when we’ve produced so much garbage that our landfills are full. Creating multiple temporal layers (between scenes of figures scavenging objects on a beach (Figure 1) and a voiceover from an archaeologist who is explaining in retrospect the origins of their condition) the designers do not redesign our landfill system (i.e. try to *fix* the problem) as much as model a possible future state of it and the human behaviors that result from that system change. They extrapolate forward in time the possible scenarios of our current system of overproduction, consumption and waste. Video’s multiple channels allow them to juxtapose future speculations (the haunting scavengers on the beach), retrospective explanations (the archaeologist’s voiceover explaining the system’s collapse), and singular artifacts of indeterminate origin (melted plastic toys actually hemorrhaged from and melted by eroded landfills on New York City’s Dead Horse beach (Figure 2). Together, these kaleidoscopic channels capture not the way to solve the problem of waste, but a way to illustrate one scenario of what might happen when we do not.



Figure 1. Still from the Video “Landfull” by Colleen Doyle, Ashley Graham, and Chisun Rees



Figure 2. Still from the Video “Landfull” by Colleen Doyle, Ashley Graham, and Chisun Rees

In the film for the project, *Choices* (studio project by Rachael Fried, June West, and Joseph Wheeler)<sup>3</sup>, the designers construct a series of visual vignettes in which everyday objects seem to instantiate a dizzying array of possible gender identities: a six-way electrical outlet that allows users to plug in their peripherals based on six gender choices (Figure 3); or a unisex bathroom that offers seven different styles of toilets based on anatomy and preference. Envisioning the collision of fluid gender identification with our hyper-consumptive habits, the designers create a series of future false “choices” that rewrite our physical landscape and reanimate our everyday life-world. The system that the actors and objects enact becomes a lens through which we see both the limitless variety of human gender expression and the bald manner in which business dimwittedly tries to capitalize on customer gender stereotypes. In each of these videos artifacts, spaces, clothing, speech, and landscape indicate the contours of possible systems—but only ever in ways that are partial. They juxtapose the familiar with the strange; designed artifacts stand in for the “whole” of a reconfigured system (Figure 4), pointing at possible futures without claiming that these futures are inevitable, likely, or even desirable.



Figure 3. Still from the Video “Choices” by Rachael Fried, June West, and Joseph Wheeler



Figure 4. Still from the Video “Choices” by Rachael Fried, June West, and Joseph Wheeler

Two more recent projects, for a studio entitled *Design for the Microbiome*, explore the quandary that started this essay: can we reimagine systems that will accommodate the invisible, beneficial microorganisms that help us to live, adapt, and thrive. In a brilliant bit of historical revisionism, Alix Gerber, Aya Jaffar, and Mei-ling Lu’s studio project *Microbiotic Covenant*<sup>4</sup> suggests that religion and ritual have always been and will continue to be a means for creating stronger bonds with these invisible mutualists. The team designed rituals—that seem both of our past and our future at the same time—in which the exchange of human bodily fluids carries a sacramental—but also evolutionary—purpose (Figure 5). Rituals, their work suggests, have been for a long time the microbes’ strategy of using humans as a means to circulate, proliferate, and strengthen their

evolutionary presence (Figure 6). Through their staging of a series of ritual moments within a non-denominational system of religious worship, they juxtapose human intention with microbial evolution. Their work challenges us to imagine whether we must redesign our contemporary rituals in order to further sanctify, strengthen, and make central the microbe-human relationship.



*Figure 5.* Still from the video “Microbiotic Covenant” by Alix Gerber, Aya Jaffar, and Mei-ling Lu



Figure 6. Still from the video “Microbiotic Covenant” by Alix Gerber, Aya Jaffar, and Mei-ling Lu

Other unknowns are raised by Isabella Brandalise, Gui Curi, and Sneha Srinivasan in their studio project *Corporation*<sup>5</sup>, which plumbs the interactions between low-wage female labor, luxury services, and the instrumentalization of the microbial body. Situating their vignette in the moment of exchange between a pedicurist and a male client, they introduce us to several microbe-oriented “services” that supplement the traditional routine and raise shrewd questions about the systems of gender, class, ethnicity, power, and the exchange of bodily fluids. As the pedicurist uses her own saliva to activate microbial colonies that will boost her client’s wellbeing (Figure 7), the project forces us to consider who will be harvesting their own microbiome for the benefit of larger, commercial interests. Are we the microbes, or are they an independent colony of silent workers that we will cultivate for their own labor and services to the benefit of others? As the female provider narrates her duties, her actions introduce us to news ways in which microbes will play a more active role in these commercial and corporeal exchanges (Figure 8).



Figure 7. Still from the video “Corporation” by Isabella Brandalise, Gui Curi, and Sneha Srinivasan



Figure 8. Still from the video “Corporation” by Isabella Brandalise, Gui Curi, and Sneha Srinivasan

Blueprints do not exist for designing for complex systems. In our attempts to struggle with this challenge we’ve patched together a range of tactics that form the basis of a larger strategy of systems design. Across these four examples—alternately dystopic, playful, ambiguous, and critical—we can identify several consistent tactics: we never “see” systems *in toto*, but systems are enacted, perturbed, and animated through the interactions of humans, non-humans, and the designed

environment that scaffolds them all; the time period is unclear, raising questions about precedent, causality, and the interleaving of past, present and future system states; and the design interventions into complex systems do not fix—in both senses of the word—the situation, but instead model possible scenarios extrapolated from current conditions.

Systems surprise. To design in the context of complex systems one must be attuned to the perverse and unintended consequences that might emerge. It is not a question of taming or solving the unknowns but modeling how they may play out and anticipating widely divergent futures. Designing to solve complex systems is impossible. But that doesn't mean we shouldn't strive to model heuristically their tendencies, potentialities, and misbehaviors.

## Correspondence

Jamer Hunt  
Vice Provost for Transdisciplinary Initiatives  
The New School  
USA  
E-mail: [huntj@newschool.edu](mailto:huntj@newschool.edu)

## Notes

1. These examples come from Studio 2, taught in the graduate Transdisciplinary Design program at Parsons School of Design, with Elliott Montgomery and Jane Nisselson in 2014 and 2015. Much of this work is inspired by Elliott Montgomery and his work on extrapolation and his speculative diagram tool: [www.extrapolationfactory.com](http://www.extrapolationfactory.com). Filmmaker Jane Nisselson has helped us to understand how we can utilize video and its visual and narrative strategies to realize system diagrams cinematically [www.vbnyc.com](http://www.vbnyc.com).
2. The full video may be viewed at: <https://vimeo.com/111375087>
3. The full video may be viewed at: <https://vimeo.com/94870320>
4. The full video may be viewed at: <https://vimeo.com/124678368>
5. The full video may be viewed at: <https://vimeo.com/128258451>

## References

- Dunne, A., & Raby, F. (2013). *Speculative Everything: Design, Fiction, and Social Dreaming*. Cambridge, MA: MIT Press.
- Meadows, D. (2008). *Thinking in Systems: A Primer*. White River Junction, Vermont: Chelsea Green Publishing.
- Rittel, H., & Webber, M. (1973). Dilemmas in a General Theory of Planning. *Policy Sciences*, vol. 4.
- Rumsfeld, D. (2002). DoD News Briefing—Secretary Rumsfeld and Gen. Myers.  
*U.S. Department of Defense*. <http://archive.defense.gov/Transcripts/Transcript.aspx?TranscriptID=2636>



# A Manifesto for Decolonising Design

**Danah Abdulla**  
**Brunel University**  
**UK**

**Ahmed Ansari**  
**Carnegie Mellon University**  
**USA**

**Ece Canlı**  
**Independent Scholar**  
**Portugal**

**Mahmoud Keshavarz**  
**Uppsala University**  
**Sweden**

**Matthew Kiem**  
**Independent Scholar**  
**Australia**

**Pedro Oliveira**  
**Heinrich-Heine Universität Düsseldorf**  
**Germany**

**Luiza Prado**  
**MeetFactory**  
**Czech Republic**

**Tristan Schultz**  
**Griffith University**  
**Australia**

Much of the academic and professional discourse within the design disciplines over the last century has been bereft of a critical reflection on the politics of design practice, and on the politics of the artifacts, systems and practices that designerly activity produces. Our premise is that— notwithstanding important and valued exceptions—design theory, practice, and pedagogy as a whole are not geared towards delivering the kinds

of knowledge and understanding that are adequate to addressing longstanding systemic issues of power.

These issues are products of modernity and its ideologies, regimes, and institutions reiterating, producing and exerting continued colonial power upon the lives of oppressed, marginalised, and subaltern peoples in both the ‘developed’ and ‘developing’ world. This planet, shared and co-inhabited by a plurality of peoples, each inhabiting different worlds, each orienting themselves within and towards their environments in different ways, and with different civilisational histories, is being undermined by a globalised system of power that threatens to flatten and eradicate ontological and epistemological difference, rewriting histories and advance visions of a future for a privileged few at the expense of their human and nonhuman others.

To date, mainstream design discourse has been dominated by a focus on Anglocentric/Eurocentric ways of seeing, knowing, and acting in the world, with little attention being paid to alternative and marginalised discourses from the non Anglo-European sphere, or the nature and consequences of design-as-politics today. This narrowness of horizons and deficiency in criticality is a reflection of the limitations of the institutions within which design is studied and practiced, as well as of the larger socio-political systems that design is institutionally integrated into.

We believe that a sharper lens needs to be brought to bear on non-western ways of thinking and being, and on the way that class, gender, race, etc. issues are designed today. We understand the highlighting of these issues through practices and acts of design, and the (re)design of institutions, design practices and design studies (efforts that always occur under conditions of contested political interests) to be a pivotal challenge in the process of decolonisation. We also want to move beyond academic discourse to critique and think around the ideas and practices that circulate through the work of professional designers embedded in the various sectors of production that stimulate and sustain the modern/colonial world economy.

Our goal is ontological rather than additive change. It is not sufficient for design institutions to simply include a greater diversity of actors or perspectives. This only goes to serve a delaying and offsetting demands for radical systemic change. While we support and defend measures to include marginalized subjects and our/their concerns in spaces from which we/they have been excluded or remain precarious, we also believe there is little point to diversifying institutions, practices, and processes that ultimately sustain colonial imperatives. Our aim is not to direct our efforts to prop up existing power structures, or to sustaining them through ameliorative measures. Rather, our aim should be nothing less than to seek the radical transfiguration of these structures through the critical eye of the programmatic imagination that dares to identify the possibilities and conditions that will give us alternatives to the now.

Our objective—as design scholars and practitioners—is to transform the very terms of present-day design studies and research. Designers can put to task their skills, techniques, and mentalities to designing futures aimed at advancing ecological, social, and technological conditions where multiple worlds and knowledges, involving both humans and nonhumans, can flourish in mutually enhancing ways. For us, decolonisation is not simply one more option or approach among others within design discourse. Rather, it is a fundamental imperative to which all design endeavors must be oriented.

It is with the aim of providing an outlet for voices from the fringes, the voices of the marginal and the suppressed in design discourse, that we have opened this platform. We welcome all of those who work silently and surely on the edges and outskirts of the discipline to join and contribute to conversations that question and critique the politics of design practice today, where we can discuss strategies and tactics through which to engage with more mainstream discourse, and where we can collectively experiment with alternatives and reformulations of contemporary practice.

We encourage and seek decentralised dialogues, in which different voices can coexist in their difference rather than in an assimilated narrative. In this platform we welcome:

- Contributions from designers working at the intersections of materiality and culture, postcoloniality, decoloniality, gender studies, race studies, and other areas of human thought and action which seek to analyse, question and challenge the relations of power in the world today;
- New curatorial practices of designerly knowledge, that seek to challenge and disrupt colonial understandings in the field and develop knowledge and understanding of how designs for decolonisation might be presented, discussed, published, disseminated, and so on;
- Reviews, interviews, debates, podcasts and other forms of discussion and debate beyond the confines of academic language. We also invite formats that are generally devalued within academic contexts such as visual essays, audio papers, performance works, etc.
- Possibilities for the dissemination of critical thinking in design well beyond the canons of the discipline (e.g. design studies and/as epistemic disobedience);
- Critical pieces written originally in languages other than English; as well as potential translations into languages other than English;
- Critical pieces written by researchers, practitioners, independent scholars, and students in the process of completing their degrees and/or who feel they are marginalised or poorly supported by academic institutions. In other words, we welcome incomplete ideas, work-in-progress, and other forms of dealing with the questions above outlined, thus amplifying discourses outside the remit of institutes, which may or may not be projects enfolded in academic work.

Moreover, we seek to connect with already existing endeavors within and beyond the design field for a decolonisation of not only academia, but all professional practices and pedagogies, to connect and foster exchanges of knowledge that speak from, cross, and remain in the borderlands of design and coloniality. Through this platform, and in collaboration with like minded others, we hope that we can make a substantial commitment to contributing to the continued existence, vitality and diversity of human presence on this planet.

## Correspondence

Ahmed Ansari  
Carnegie Mellon University  
USA  
E-mail: aansari@andrew.cmu.edu

## Notes

Decolonising Design Collective is made up of Danah Abdulla, Ahmed Ansari, Ece Canlı, Mahmoud Keshavarz, Matthew Kiem, Pedro Oliveira, Luiza Prado, Tristan Schultz. This piece of writing initially appeared as an Editorial Statement at <http://www.decolonisingdesign.com/statements/2016/editorial/> and has since been updated and edited.

## References

Decolonising Design Collective. (Revised 2017, June 27). *A Manifesto for Decolonising Design*. Retrieved from <https://www.decolonisingdesign.com/statements/2016/editorial/>



***DESIGN AND FUTURES***  
***Volume II***



# Introduction to the Special Issue: Design and Futures (Vol. II)

**Stuart Candy**  
**Carnegie Mellon University**  
USA

**Cher Potter**  
**University of the Arts London**  
**Victoria and Albert Museum**  
UK

Volume I of this special double issue of the *Journal of Futures Studies* ‘Design and Futures’ – the largest themed project in the history of the journal – began by noting something that is increasingly self-evident to anyone paying attention: the fields of futures and design are merging in a process of dialogue, experimentation, and mutual discovery. Obvious perhaps, and yet this process and the practices and perspectives it engenders are nonetheless remarkable. They show no sign of abating.

The dialogue continues (note we do not say ‘concludes’) here in Volume II, with scholars and practitioners from across the two fields, and beyond, delving more deeply into the practical and philosophical issues at various intersections. Both established and emerging voices share generously of their case studies, lessons learned, and methodological questions. They traverse the worlds of media, design, curation, and strategic foresight; they propose research strategies that cross community perspectives and shift our geographical (and political) focus to different sites for design and futures. To adapt an observation from cultural geographer Denis Cosgrove, “position and context are centrally and inescapably implicated in all constructions of [design and futures] knowledge” (Cosgrove, 1999, p. 7).

This second volume of ‘Design and Futures’ opens with seven peer-reviewed articles from a constellation of contexts, spanning five continents: Maya van Leemput (Belgium) distils lessons from many years of relational work and play where futures meets media, art and design. Leah Zaidi (Canada) illuminates the importance of worldbuilding as an emerging practice that intersects science fiction with real-life applications of design and foresight. Ralph Borland (South Africa) outlines a case study of interventionist art from the streets of Cape Town as an instance of guerrilla futures activism. Karla Paniagua (Mexico) describes the first four years of running a postgraduate design/futures program in the highly energetic and fast-changing context of Latin American foresight practice (*la prospectiva*). Stefanie A. Ollenburg (Germany) offers a generic ‘research through design’ framework, inviting researchers to hybridise futures and design in participatory projects, early and often. And finally, a pair of case studies from Taiwan: Jeanne Hoffman investigates preferred future images about the environment in 2060 as held by a cross-cultural cohort of undergraduate students; and Kuo-Hua Chen considers the possibility of designing for increased environmental awareness among young Taiwanese through a suite of futures interventions in curriculum.

These are followed by a potent collection of shorter essays and interviews from philosopher Timothy Morton; Museum of Modern Art curator Paola Antonelli; transdisciplinary artists Maja Kuzmanovic, Tina Auer, Tim Boykett and Nik Gaffney; designers Nik Baerten, Dan Hill, and Lucy Kimbell; futurists Aaron Rosa and John Sweeney; NASA visual strategist David Delgado; architect Lizzie Yarina, and design theorist Tony Fry.

Taken in singularity, these voices are strikingly diverse, but when hearing them together, they begin to harmonise. It is the music of a community emerging.

Through this issue, we encounter contemporary questions around design and futures in the twenty-first century, as well as ageless questions about what it means to be human, and the nature of time itself. We're excited to see what these may do to help deepen, enrich and catalyse further activity and exchange.

It seems fitting that this second volume starts and ends with articles about journeys. This project has been a remarkable journey for us as guest editors – with several years of work spanning multiple job changes, international relocations, and children being born – as well as tremendous changes in the context of design and futures themselves. In spite of expanding this themed publication to two volumes, the interest and contributions have far exceeded our expectations. It is gratifying that the relevance of this undertaking continues to grow apace.

We wish to express our gratitude to all authors who submitted proposals; our wonderful peer reviewers; our incredibly understanding partners on the home front; and not least José Ramos of the *Journal of Futures Studies*, without whose tireless support this project would not have been possible.

## Correspondence

Stuart Candy  
Carnegie Mellon University  
USA  
E-mail: scandy@cmu.edu

Cher Potter  
University of the Arts London  
Victoria and Albert Museum  
UK  
E-mail: c.j.potter@arts.ac.uk

## References

Cosgrove, D. E. (1999). *Mappings*. London: Reaktion Books.

# Destinations for Polyamorous Futures and Their MAD Lovers

Maya Van Leemput  
Erasmus University College  
Belgium

---

## Abstract

*When futures meets design, we can build collaborations, use each other's tools and perspectives and plot a course for a destination beyond our fields. Futures and design are well suited to working together 'en route' to a society where creative processes activate collective imagination with a keen awareness that multiple futures are possible. This article draws on the author's interdisciplinary practice to examine what the collaboration between futures and media, art and design (MAD) has to offer and what makes it possible. It suggests that we recognise the interdisciplinary (polyamorous) nature of futures, that we get close to pool resources, that we use media-rich approaches for their ability to shape images of the futures and for co-creation with people outside of our fields. It lists lessons learned from a sample of three projects and indicates do's and don'ts that futurists can keep in mind for making the most of the collaborations and relationships that form at the intersection between futures and design.*

**Keywords:** Arts and Design, Co-creation, Collaboration, Images of the Futures, Media, Social Foresight.

---

## Travelling Together

At the intersection of futures and design, the two sets of practice and thought are set to have more than fleeting encounters. When futures meets design, we can build collaborations, use each other's tools and perspectives, and plot a course for a destination beyond our fields: a forward-looking and generative stance with critical awareness of alternative futures in all sections of society. If we undertake that journey together, we need strong partnerships and collaborations informed by mutual understanding and realistic expectations.

If we are to be travel companions, then the relationship metaphor used by Stuart Candy (2010), suggesting that futures and design are getting married, and exploring the basis for that partnership as well as the nature of its potential offspring, is particularly useful. We are not merely passing strangers whose paths cross accidentally, and so we are challenged to make our relationship work.

In this context, mine is a privileged position. I am a futurist with a long-standing collaboration with a visual artist who is also my life partner. Our shared practice began 20 years ago with a three-year field journey for collecting and producing images of the futures in 28 countries across five continents (Agence Future, 2012).

We use ethnographic approaches borrowing from visual anthropology in combination with motives and approaches from audio-visual media and visual arts. Over time our experimental work evolved to include other artists and creative professionals who take on specific roles in joint futures projects.

I will draw on this practice to examine what makes collaboration between futures and media, art and design possible and consider the advantages of travelling together. I will list lessons learned from a sample of three projects and indicate do's and don'ts that futurists can keep in mind for making the most of the collaborations and relationships that form at the intersection between futures and design.

The projects that will be discussed, fit in with the designerly practices addressed in the critical design and futures literature of the past decade that points out the democratising potential of the relationship between futures and design (Candy & Dunagan, 2017; Dunne & Raby, 2013).

The earliest of the projects described below relied on modes of inquiry more typical for journalism and media production than for design. Later projects have included artists' work that references futures methods or signposts futures without however presenting images, artefacts or situations concretely as possible futures. Nevertheless, these specific variants fit well in the family of practices at the intersection between futures and design. In respect of my own practice I will refer to them as 'media, arts and design' and for brevity (and for fun) use the acronym MAD.

I do not argue for adopting MAD approaches to the exclusion of others, but want to emphasise the considerable potential of collaboration with MAD for concrete and strategic futures work. I contend that partnership with MAD can amplify the diversity of images of the futures and be useful for learning how these images are (or can be) created and activated collectively as well as individually. I want to ensure that we don't just brush the surface of the potential that is present here by merely using forms of one for thoughts of the other to remain stuck in business as usual. I am interested in the opportunities afforded to futures by media-rich approaches for expanding and fortifying the possibilities for inclusive personal as well as local and global conversations on alternative futures and for bringing these conversations to bare on the present. It is my view that futures and MAD are well suited to working together 'en route' to a society where creative processes activate collective imagination with a keen awareness that multiple futures are possible.

## **Polyamorous Futures and MAD as A Preferred Partner**

### **What counts**

In her article 'New challenges for futures studies' that appeared almost two decades ago, Eleonora Masini (2001, p.637) puts forward that rapid and interrelated changes in social reality mean that "no discipline on its own can face the different correlated and global challenges". Futures work inevitably is a multi-, inter-, trans-, or cross-disciplinary activity (the exact nomenclature depending on how precisely you like to mix and mingle). It requires multiple partnerships and collaborations, and that is a very specific determining condition for the marriage between futures and MAD.

Futures operates on the basis that the characteristics of any future environment will relate to factors internal as well as external to that environment. In this respect futurists learn to think about driving forces and pay attention to the trends and emerging issues, the motors and objects of change pertaining to many different environments (Dator, 2018; Sardar & Sweeney, 2016). In addition, applied futures research can direct its attention to any particular setting, question or subject with a variety of 'futures of X' work. This kind of work — that several generations of futures students practiced in assignments set by Jim Dator at the University of Hawaii, and that is also at the heart of much of the commissioned work by research agencies and consultants — requires knowledge and experience appropriate to X. There is no limit to the diversity of thematic choices available. In addition, futures projects can address a range of scales, from individual futures, to local, regional,

national, or international outlooks, and different views can be cast: issue-driven, case-driven, location-based, for different time horizons and different sets of values. In all this variety, knowledge and insight from more than one specialisation are relevant, and interdisciplinary work is called for.

In practice, the expertise required for the specificity of each project is most often brought in by clients and stakeholders, or comes from collaborating academics with different backgrounds. In my own practice I have worked with historians, economists, social geographers, linguists, political scientists, media scholars, technologists, engineers and physicists and philosophers. They all contributed their own subject specific proficiency to projects. Artists or designers more often contribute skills, knowledge, experience, perspectives or approaches, based on methods rather than on subjects. Here they come into an already crowded space as futures methods, tools and techniques are a mixed bag with relatively few methods unique or exclusive to futures (Aaltonen, 2009).

It is clear that the kind of interdisciplinary collaborations that futurists need to build for concrete projects are context dependent. These partnerships cannot be fixed according to a pre-existing set of rules but must grow and develop according to the needs of the work at hand and the dispositions of all involved. Overall this is more akin to polyamory than to marriage. Polyamory is a practice based on the principle that (romantic or sexual) relationships do not have to be exclusive. Just as is the case for interdisciplinarity, there are many variations. A British and an American polyamorist may not mean exactly the same by the term. There are open and closed variants, ranging from versions of ‘anarchist love’ that see all kinds of relationships (including outside of the realm of romance) as equal, to versions that label partners as primary or secondary or that demand polyfidelity. If the partnership between futures and MAD is going to work, we will need to make explicit the assumptions on which it is based, and think about the what, how and why. The stereotype ‘it’s complicated’ is certainly applicable. Both at the scale of concrete projects, and more strategically en route towards a collective capacity for imagination and foresight, we have to work out together what works and what doesn’t.

So why and how can MAD count as a preferred companion for futures among many potential and actual partners? The most obvious motivation for including its media-rich approaches in the multitude of futures work is their communicative power (Mitchell, 1996). It makes sense to make the most of that in futures or foresight communication, project interfaces and reporting. (Ramos, 2006) Even so, MAD approaches — like storytelling and visualisation, deeply rooted and ancient practices; also the darlings of contemporary marketing and communication literature — have more to offer than rallying force, attention and retention. A further motive for futurists to work with MAD relates to the functional proximity between the two sets of practices. The next basis for affording MAD tools a special status, among the many kinds of tools that futurists use, is their capacity for visualisation and narrative development, uniquely suited to the creation of images of the futures. The final ground for working with MAD tools and people, which will be discussed below, is their aptitude for co-creation and inclusivity.

### **From practice**

In my longstanding collaboration with photographer and videographer Bram Goots on Agence Future, the two of us are both literal and metaphorical travel companions (Agence Future, 2012). Since the year 2000, we have recorded semi-structured interviews and orientation conversations with over 750 people spread over five continents. We intentionally combine approaches from different fields of practice (Van Leemput, 2005). Specifically, we blend academic futures research with multi-media and visual arts, and with journalism. The hunt for a soundbite, an unashamed engagement with personal stories, and the use of quick fire 10-minute street interviews (next to sometimes day-long in-depth interviews) all brought in by the journalistic lens also deliver in terms of research results. Still photography in the present-day environments to which our conversation partners guide us often no more than suggests that futures can be perceived in the present. All of the

protocols and techniques from these domains, design or other, help us ask questions in more ways than one, as well as process and analyse what our conversation partners talk about with different filters. Creating concrete visual narratives — images of the futures — with research participants, away from the interviews with them, offers a form of interdisciplinary triangulation.

### Lessons learned

Considering how futures must partner with multiple other fields, and how overall — based on the specific preferences and predilections of individual futurists — futures seems to be able to love most any subject or method; and considering also that MAD have as many different associations, the relationship, though privileged, looks distinctly like a polyamorous one.

*Do: in this situation, accept that there is no orthodoxy and that this may be somewhat uncomfortable, not just for the partners in the collaborations but also for external observers whose expectations are challenged.*

*Do: with so many options open to us, work out, case by case, what really fits, and ensure detailed customisation and tailoring to the settings and demands of any specific project.*

*Do: look for multiple matches and expand your horizons.*

*Don't: think polyamory comes easily; figuring out a modus operandi that respects the ambitions and assumptions of all involved, and that gives space to what each partner can contribute for making the journey a success, requires careful attention.*

*Don't: stick to just one mode of collaboration or set patterns.*

*Don't: demand exclusivity or have pre-set expectations of what the other brings into the relationship.*

## Proximity and A Shared Sense of The Game

### What counts

“Designers need futures. Futurists need design. Each speaks to something that the other lacks” argues Stuart Candy (2010, p.165). He sees futures and design as “isomorphic enterprises” with similarities “built into their very structure” (2010, p.171, p.179). This is what provides the proximity needed as a starting point for concrete collaboration. I will use the example of my work for *A Temporary Futures Institute (ATFI)*, a group exhibition at the Museum of Contemporary Art of Antwerp (M HKA), with alternative futures as its central theme, to show how this proximity affords a shared sense of the game and brings futures and MAD close enough to pool our resources and collaborate fruitfully.

### From practice: A Temporary Futures Institute

The senior curator of the M HKA, Anders Kreuger, and I started preparing *ATFI* almost two years before the opening of the four-month show (M HKA, 2017). At the outset our bi-weekly meetings compared the theory and practice of our contexts, with particular attention to parallels and resemblances. Besides certain shared characteristics and perspectives — the generative and intentional nature of processes, knowledge as contingent — what stood out to us were the similitudes of the everyday behaviours and expectations of the individuals, groups, organisations and institutions involved.



Figure 1. The seventeen screens of 'A Conversation Piece' by Agence Future at A Temporary Futures Institute. Photo: Bram Goots



Figure 2. The co-curators of A Temporary Futures Institute show Jim Dator around the exhibition. Photo: Bram Goots

*ATFI* was explicitly conceived and implemented as a collaborative undertaking. More than a dozen artists and futurists, including Agence Future, collaborated on the show and a whole ecosystem of museum staff was involved (see Figures 1 and 2). In addition, the research centre Open Time | Applied Futures Research at the Management, Media and Society department of the Erasmus University College Brussel (where I am senior researcher and coordinator) with a handful of international partners, organised a unique futures conference, titled *Design Develop Transform (DDT)* inside and alongside the exhibition (Design Develop Transform, 2017). While the working conditions of all the individuals that collaborated on *ATFI* were not alike, the administrative and seasonal rhythms of the college and the museum determined everyone's tempo and rhythm. A shared practical sense and a common understanding of how to think about what works and what doesn't, and how to act accordingly (even if what concretely should be done could be the topic of hot debate), made the collective effort possible. Krueger and I as co-curators were struck by a persistent sense of familiarity and recognition. Attitudinal and behavioural characteristics that we both ascribed to our professional backgrounds made the collaboration stick.

In collaborations between futurists and artists (or other creatives), how we operate together is set by our sense of the game, our workplace environments, habits and implicit assumptions. Bourdieu's concept of habitus or what is 'second nature' to people, given by what they learned formally and also through experience in their specific contexts or fields, helps understand this. "Habitus is internalised experience, embodied culture and history", writes Bourdieu commentator Philip Gorski (2013). Bourdieu's discussion of habitus in the field of art offers a useful parallel for what futures and MAD have in common that makes them a good polyamorous match.

*Like habitus, 'the rules of art' is a phrase that signifies practical knowledge, learning-by-doing, tacit understanding[...] Art can never be reduced to following set rules and yet to say it is without coherence, strategy, or intention, or not based on socially organised and shared knowledge, would be to misunderstand it utterly. (Calhoun, 2002)*

Futures and MAD are similarly coherent, strategic and intentional enterprises. Pre-existing experience within these fields provides a solid basis for striking original relationships and collaborations in which the partners themselves set the standards and determine the final destination of their journey together.

I will not attempt to discuss the core of Bourdieu's field theory here, but the idea of a "domain of relative autonomy marked off from others by its distinctive hierarchy, values, struggles, styles of improvising action, and forms of capital" (Gorski, 2013) is helpful for thinking about interdisciplinarity as well as proximity. The fields of futures and MAD are distinguished neighbours in the overall context of cultures and societies. This means that we can share resources, combine processes and agree on common goals. The example of the *ATFI* exhibition and *DDT* conference, created by pooling different forms of capital, is telling. We combined financing streams (economic capital); we combined people from our networks (social capital); we also combined our learnings (academic capital) and brought the status of our institutions and individual collaborators (cultural capital) to bear on the project. It is fair to say that together we were better than alone and could travel further.

### Lessons learned

Mutual frames of reference make for suitable travel companions. Similarities built into the structure of futures and MAD produce a closeness between the habitus and dispositions in these fields. They invite us to find each other and even inhabit each other's space.

**Do:** *at the intersection, make use of being close to each other; keep an eye on each other; read each other's books; and talk; get to know each other.*

*Do: take part in each other's activities, even away from the intersection where each does their own thing independently.*

*Do: make the whole more than the sum of the parts.*

*Don't: deny a partner's autonomy, and don't give up your own.*

*Don't: crowd each other or force other partners upon each other.*

*Don't: expect MAD to be just the pretty one in the relationship. Institutions, professionals, collectives and publics from the fields of MAD have more to bring than aesthetics or style.*

## **Mad Tools for Visualising and Narrating Futures**

The choice of words in the field of futures suggests that futures are to be visualised. There is *foresight* and *la prospective* (Godet, Durance, & Gerber, 2008); we have *visioning* and even *visions* (Dator, 2011; van der Helm, 2009; Jungk & Müllert, 1987). Jim Dator presents the main subject of futures studies explicitly as “*images of the futures*” in his classes (Dator, 2002). Much of the time, however, we think of futures in terms of concepts, ideas or metaphors, and more seldom do we refer literally to pictures; tangible visual images. With the tools of MAD, concepts are challenged by images and stories, if not full experiences of body and mind. This provides one of the starting points for the media-rich practice of Agence Future with Bram Goots. Visual and narrative approaches are useful at all stages of our work, from mapping to developing alternatives, deepening, capturing, documenting, reporting, and relating images of the futures.

### **From practice: Agence Future's Reel Molenbeek Futures**

For a year-long project in the disadvantaged neighbourhood of Molenbeek in Brussels, Goots and I approached a core group of 5 selected residents with a camera from the start (Reel Molenbeek Futures, 2011). We explained that we were conducting research about personal and local futures in their home community and at the same time shooting a film on this subject. We asked the participants to indicate possible subjects, places and activities to film for illustrating the ideas they related during their interviews, challenging them to fill in the blanks in their ideas on the futures. This was the basis for a collection of unique stories about Molenbeek in the future.

Concretely visualising futures with the participants in Molenbeek aided their elaboration of alternative images of the futures. It stimulated their imagination and helped them arrive at well-constructed narratives of future possibility. For instance, over the course of three consecutive interviews, 32 year-old Touben came up with a location and props to allow us to film him engaged in the activities and placed in the surroundings he had described for his old age. As he developed ideas for the video, he provided descriptions of future modes of transport and of public spaces in his neighbourhood. Touben also suggested depicting the future multi-lingual character of the neighbourhood and his own personal development by posing with a newspaper in a different language than is commonly used in Molenbeek today. With Dina, a teenage girl who was uncertain whether her ambition was to be a police woman or a fashion stylist, the device of preparing to film her in the situation she was thinking of, prompted her to review where both professions would take her, and what their environments would have to offer. She weighed up her attraction to the materials and tools of the couturier's studio against the desirability of contributions to neighbourhood life that she might make as a policewoman, also considering if in future, wearing a headscarf would be an option in either profession. Fashion won over policing, but in her follow-up interview after the shoot in the couturier's studio, Dina expressed new arguments for this possibility as well as against it.

In the initial stages of their interviews, both participants had far less to say about details of the futures they described than they did once asked to consider putting this future into a scene, and actually going through the process of doing so. Their engagement with the challenges of visualisation and storytelling for an audio-visual end product deepened their engagement with future

possibilities. The resulting images of the futures connected the personal and the local, and produced essential alternative narratives beyond predominant images of a neighbourhood lacking future opportunities for its young residents.

### Lessons learned

Aiming towards concrete images of the futures, deploying tools from the fields of MAD supports the rigour with which we ourselves and participants in our projects create images and narratives of the futures. As has been argued by Milojevic and Inayatullah (2015) as well as Jarva (2014) in their discussions of narratives in futures studies, this is crucial for orientation in the present and awareness of alternative future possibilities.

*Do: use MAD tools for asking questions.*

*Do: use MAD tools for arriving at multi-dimensional images of the futures.*

*Do: it for the learning curve of everyone involved.*

*Don't: use flat or superficial images of the future; they don't lead anywhere near the kind of destination we have in mind here.*

### Co-Creation

#### What counts

Wendell Bell (2002, p. 39) teaches that in futures studies, the process of “image making itself”, is studied to “encourage people to rigorously explore alternative images of the future and construct images of the futures themselves”. He argues that “Futurists encourage people to look beyond the familiar and to search for opportunities for themselves and their organisations...” Participative and co-creation approaches serving this democratic reflex fare particularly well when MAD approaches are fully implicated in project designs. While theorising possibilities for the futures may be a specialist competency, the affective tools and techniques of MAD can open this realm up to others. Merritt Polk (2015, p. 110) points out how transdisciplinary co-production with non-expert actors can stimulate “a high level of stakeholder participation and commitment to the research processes, and promoted knowledge integration and reflexive learning.” This was our experience with *Reel Molenbeek Futures* and also with *MAONO 0201234*.

#### From practice: *MAONO 0201234*

From 2012 until 2014, Agence Future ran a mixed methods project titled *MAONO*. Over the course of three years, 15 artists and 41 young adults based in Katanga’s provincial capital Lubumbashi in Democratic Republic of the Congo, and 40 young adults from Brussels, worked together to observe, collect and create images of the futures. The primary tool used by the young adult participants was a ‘Roadbook’ containing 21 missions. Each mission explored possible futures and was completed with an image, which could be a photo, a video-still, a clipping, collage, or drawing; and even sound recordings have been made. In collaboration with the young adults, local artists then created 16 pieces, including musical recordings, a poem, a comic strip, sculptures, drawings, and poetic video documentaries (Van Leemput, 2015). (See Image 3.)

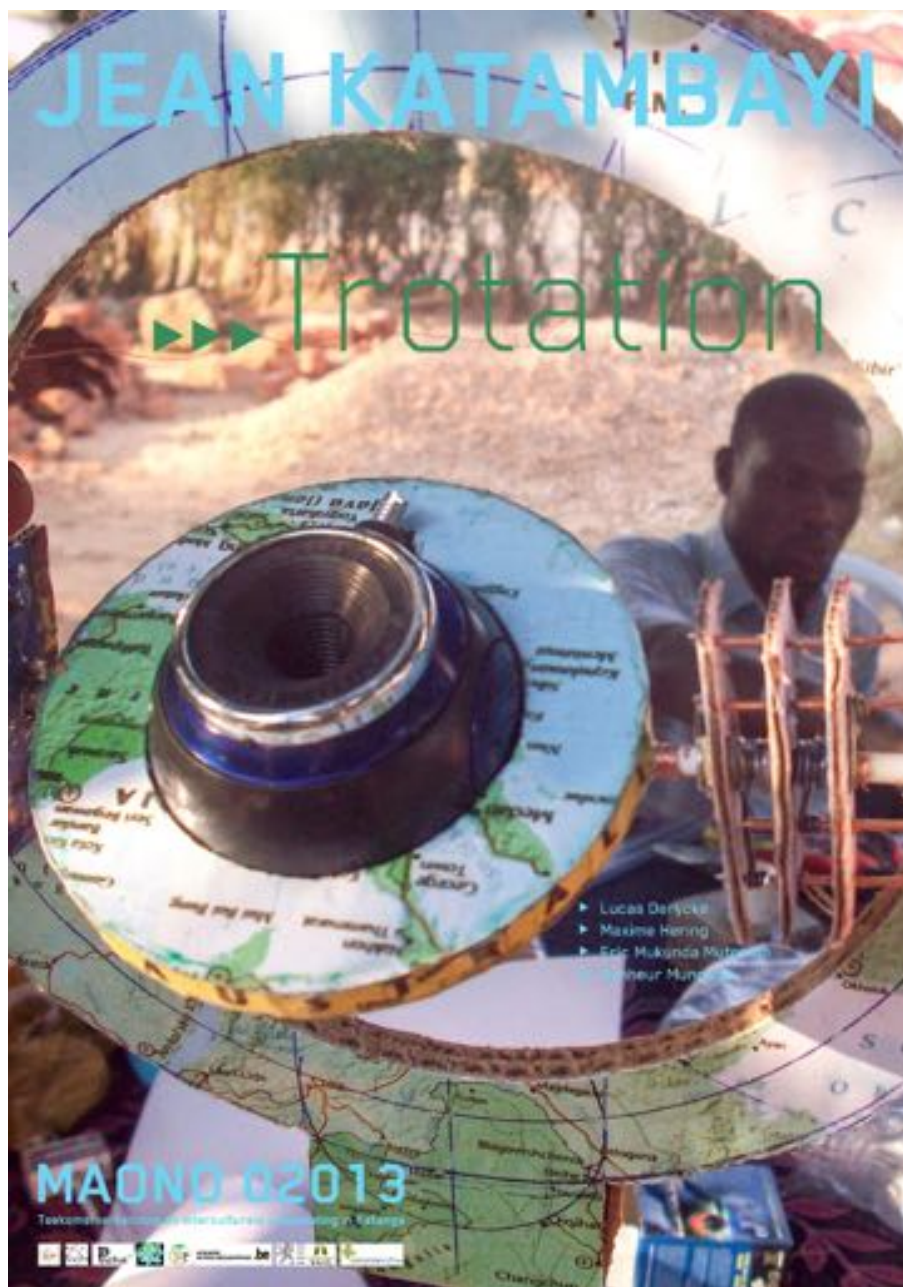

Figure 3. One of the seventeen different MAONO posters distributed in Lubumbashi and Brussels presents Jean Katambayi's *Trotation*. Photo: Bram Goots

The requirement of providing concrete images for each of the Roadbook missions, for most of our participants meant a challenging switch to visual thinking, in addition to the switch from present-day thinking to long-term visioning. Finding and making images was an uncommon method, taking the young participants out of their routine and encouraging them to think differently. A daily loan system of recording equipment, particularly attractive to the young Congolese participants, aided their commitment. Their engagement increased with practical guidelines and tips from our

professional photographer. The night-time conversations around the two portable printers, about photos shot earlier, provided as much reflexive learning and knowledge integration as any of the accompanying workshops.

For the participating artists, translating ideas into concrete images was everyday business. They were already involved in shaping and re-shaping reality, creating different forms, sights and sounds. Both in *Reel Molenbeek Futures* and in *MAONO*, participants received critical support from our photographer and other participating artists, getting access to the professional tools and skills of seasoned image-makers. The advances made by all concerned in the live collaboration and negotiations between the artists and the young participants were considerable. The project yielded images of the futures that were shared widely. With projects like *MAONO* diverse images of the futures are brought into the world to activate the present, provide orientation, and affect mindsets, actions and behaviours. Collaboration with MAD can make this work more effective and open up a much-needed space where individuals and groups can engage with multiple future possibilities, away from futures colonised by only a few predominant images of the future (Sardar, 1993).

### Lessons learned

The polyamorous spirit of futures and MAD allows these partners to invite a host of others as travel companions to explore multiple futures together and report on the journey.

*Do: use MAD approaches for facilitating participation and co-creation.*

*Do: provide a goal-oriented context and means.*

*Do: make a point of sharing generative procedures, creative processes and skill sets.*

*Don't: just use MAD approaches for better communication, illustration or window dressing.*

*Don't: let differences between points of view or abilities, part and parcel of any relationship, stop you.*

### Destinations

Projects like *ATFI* and *DDT*, *Reel Molenbeek Futures*, and *MAONO* are part of a varied journey of exploration with my MAD lover and many other MAD friends and colleagues as travelling companions. The destinations for these collaborations can be described simply as their goals. The first set of goals is making the projects themselves possible, and making them suited to inclusive co-creation of qualitative, multi-dimensional images of the futures. The next goal is to activate and include multiple perspectives and capacities in actual conversations about local and global futures. Ultimately, the aim is to make these conversations matter, in other words, to boost the social capacity for foresight and bring it to bear on the present.

That the partnership between futures and MAD may be able to navigate towards such a far-reaching goal is a point that has been made convincingly by Candy and Dunagan (2017), Brassett and O'Reilly (2015), de la Pena (2017) and others. Futures and MAD meet at an intersection in a diverse environment that is at the same time the object and the subject of the activities we undertake. From here we can set out to produce occasions for different actors to create, work and play with images of the futures. As we travel outward from our common point of departure, we create a strategic space for alternative futures to be present and understood in. The path may really be the destination. Our journey has the potential to extend crucial qualities of our habitus beyond our own fields, and infect our cultures and societies with the freedom, intentionality, imagination and procedural scaffoldings of the theory and practice of our fields.

### Lessons to be learned

The do's and don'ts listed above may be much like relationship advice; they also provide procedural suggestions for collaborations between futures and MAD navigating towards a hard to

reach common destination in a complex reality. They emphasise the need for (1) getting close and (2) pooling resources without pre-set rules, (3) careful adaptation to contexts, (4) asking questions in multiple ways, and (5) including others and sharing our practices with them. They warn against (1) set patterns, (2) losing distinctions, (3) superficial application, and (4) fear of differences.

*Do: build collaborations to plot a course for a destination beyond our fields.*

*Do: take care of your travel companions, share with others and adapt to the surroundings.*

*Don't: forget to enjoy the scenery.*

## Correspondence

Maya Van Leemput, Ph.D

Agence Future

Belgium

<http://www.agencefuture.org>

E-mail: [maya@reelfutures.net](mailto:maya@reelfutures.net)

## References

- Aaltonen, M. (2009). Evaluation and organization of futures research methodology — v3.0. In J. Glenn & T. Gordon (Eds.). *Futures research methodology – Version 3.0*. Washington, DC: Millennium Project. Retrieved from <https://pdfs.semanticscholar.org/e715/fd10fd25773939b-863f634cb4521c3f45367.pdf>
- Agence Future. (2012). Retrieved from <http://www.agencefuture.org>
- Bell, W. (2002). Making people responsible: The possible, the probable, and the preferable. In J. A. Dator (Ed.), *Advancing futures: Futures studies in higher education* (pp.33-53). Westport, CT: Praeger.
- Brassett, J., & O'Reilly, J. (2015). Styling the future. A philosophical approach to design and scenarios. *Futures*, 74, 37-48. doi:10.1016/j.futures.2015.07.001
- Calhoun, C. (2002, July 1). Social science, social conscience: Remembering Pierre Bourdieu. *The Brooklyn Rail*. Retrieved from <https://brooklynrail.org/2002/07/express/social-science-social-conscience-remembering-pierre-bourdieu>
- Candy, S. (2010). *The futures of everyday life: Politics and the design of experiential scenarios* (Ph.D Dissertation). Department of Political Science, University of Hawaii at Manoa. doi:10.13140/RG.2.1.1840.0248
- Candy, S., & Dunagan, J. (2017). Designing an experiential scenario: The people who vanished. *Futures*, 86, 136-153. doi:10.1016/j.futures.2016.05.006
- Dator, J. A. (Ed.). (2002). *Advancing futures: Futures studies in higher education*. Westport, CT: Praeger.
- Dator, J. A. (2011) Futures studies. In W. S. Bainbridge (Ed.), *Leadership in science and technology, Vol. 1* (pp. 32-40). Thousand Oaks, CA: Sage.
- Dator, J. (2018) Emerging issues analysis: Because of Graham Molitor. *World Futures Review*, 10(1), 5-10. doi:10.1177/1946756718754895
- de la Pena, D. (2017). *Design as democracy: Techniques for collective creativity*. Washington, DC: Island Press.
- Design Develop Transform. (2017). *DDT Conference* website. Retrieved from <https://ddtconference.org>
- Dunne, A., & Raby, F. (2013). *Speculative everything: Design, fiction, and social dreaming*. Cambridge, MA: MIT Press.

- Godet, M., Durance, P., & Gerber, A. (2008) *Strategic foresight / La prospective: Use and misuse of scenario building*. Cahiers du LIPSOR, Working Paper #10. Paris, France: CNAM.
- Gorski, P. S. (Ed.) (2013). *Bourdieu and historical analysis: Politics, history, and culture* (pp.36-67). Durham, NC: Duke University Press.
- Jarva, V. (2014). Introduction to narrative for futures studies. *Journal of Futures Studies*, 18(3), 5-26. Retrieved from <https://jfsdigital.org/wp-content/uploads/2014/04/183-A02.pdf>
- Jungk, R., & Müllert, N. (1987). *Future workshops: How to create desirable futures*. London: Institute of Social Inventions.
- M HKA. (2017). A temporary futures institute. *M HKA* website. Retrieved from <https://www.muhka.be/programme/detail/660-a-temporary-institute-of-futures-studies>
- Masini, E. (2001) New challenges for futures studies. *Futures*, 33(7), 637–647. doi:10.1016/S0016-3287(01)00006-4
- Milojevic, I., & Inayatullah, S. (2015). Narrative foresight. *Futures*, 73, 151-162. doi:10.1016/j.futures.2015.08.007
- Mitchell, W. J. T. (1996). What do pictures *really* want? *October*, 77, 71-82. Retrieved from [https://monoskop.org/images/2/25/Mitchell\\_WJT\\_1996\\_What\\_do\\_Pictures\\_Really\\_Want.pdf](https://monoskop.org/images/2/25/Mitchell_WJT_1996_What_do_Pictures_Really_Want.pdf)
- Polk, M. (2015). Transdisciplinary co-production: Designing and testing a transdisciplinary research framework for societal problem solving. *Futures*, 65, 110-122. doi:10.1016/j.futures.2014.11.001
- Ramos, J. (2006). Consciousness, culture and the communication of foresight. *Futures*, 38, 1119-1124. doi:10.1016/j.futures.2006.02.015
- Reel Molenbeek Futures. (2011) (video). Retrieved from <https://vimeo.com/56018826>
- Sardar, Z. (1993). Colonising the future: The ‘other’ dimension of futures studies. *Futures*, 25(3), 179-187.
- Sardar, Z., & Sweeney, J. (2016). The three tomorrows of postnormal times. *Futures*, 75, 1-13. doi:10.1016/j.futures.2015.10.004
- Van der Helm, R. (2009). The vision phenomenon: Towards a theoretical underpinning of visions of the future and the process of envisioning. *Futures*, 41(2), 96-104. doi:10.1016/j.futures.2008.07.036
- Van Leemput, M. (2015). *MAONO: Co-creation of images of the futures*. Node Center for Curatorial Studies, Berlin. Retrieved from <https://www.nodecenter.org/maono-co-creation-of-images-of-the-futures/>
- Van Leemput, M. (2005). Diverging methods in single futures research projects. In M. Potůček, & B. Slintáková (Eds.), *Proceedings of the Second Prague Workshop on Futures Studies Methodology* (pp.170-181). Prague: CESES / Charles University. Retrieved from [https://ceses.cuni.cz/CESESENG-62-version1-sesit05\\_10\\_potucek.pdf](https://ceses.cuni.cz/CESESENG-62-version1-sesit05_10_potucek.pdf)

# Worldbuilding in Science Fiction, Foresight and Design

Leah Zaidi  
Independent Scholar  
Canada

---

## Abstract

*Science fiction is experiencing a renaissance as the rate of change and uncertainty about the future increases. Organizations, innovators, and changemakers alike are turning to the genre to navigate the future and design for the present, often unaware that generating and using images of the future for strategic purposes is a cornerstone of foresight practice. A fundamental concept in science fiction that is fueling the use of the genre as a strategic tool is worldbuilding. This paper explores how worldbuilding is currently leveraged, how it relates to design and foresight, and how it might further enrich both disciplines. It will propose that design and foresight may benefit from the worldbuilding processes of science fiction authors to design for coherence, user-test worlds, and help society develop a superstructure of culture in order to imagine and create new visions of the future.*

**Keywords:** Design, Science Fiction, Social Foresight, Worldbuilding.

---

## Introduction

Stories are powerful. A story “can be a way for humans to feel that we have control over the world. They allow people to see patterns where there is chaos, meaning where there is randomness. Humans are inclined to see narratives where there are none because they can afford meaning to our lives — a form of existential problem-solving” (Delistraty, 2014). Creating fiction — our ability to envision possibilities outside of our immediate reality — has served as an evolutionary advantage for our species. Historian Yuval Noah Harari argues that it is our propensity to create and perpetuate mass mythologies that defines humanity and our dominion over reality (Harari, 2015).

Often, stories have the power to change us on a fundamental level because our brains process moral lessons coded in narratives differently. Researchers have found that “narratives that appeal to ‘protected values’, including core personal, national, or religious values, may be particularly effective at influencing receivers. Protected values resist compromise and are tied with identity, affective value, moral decision-making, and other aspects of social cognition” (Kaplan et al., 2017, p.1). When we encounter moral lessons in the form of a narrative, our brains show increased activity, and we engage more deeply than we would otherwise.

From Mary Shelley to Robert A. Heinlein to William Gibson, science fiction has provided the world with stories about the future. Science fiction is, in the broadest sense, fiction that follows science. It depicts “plausible

futures — envisioning where contemporary social trends and recent breakthroughs in science and technology might lead us” (Gunn, 2014). It is a sociology of the future (Toffler, 1970, p.208). A vast and varied genre, science fiction is a subset of speculative fiction — a super-category that embraces alternative realities (Oziewicz, 2017).<sup>1</sup>

Science fiction is experiencing a renaissance as the rate of change accelerates, and we grow more uncertain about the future. Organizations, innovators, leaders, and changemakers are turning to the genre to navigate the future and design for the present, perhaps unaware that generating and using images of the future for strategic purposes is a cornerstone of foresight practice. In particular, the concept of worldbuilding in science fiction may offer new insights at the intersection of foresight and design that may strengthen the growing bond between them. This paper will explore how science fiction is currently impacting real-world design, how worldbuilding overlaps with foresight and design, and how worldbuilding in science fiction might further enrich both practices.

## The Application of Science Fiction

Science fiction holds significant influence over technological innovation and scientific research. For instance, Jules Verne inspired the U.S. Navy’s first submarines and the modern helicopter (Tavakoli-Far, 2013). It was Arthur C. Clarke who first proposed using satellites for global communications in 1945 (Tweney, 2011). Everything from the desire to visit “Mars to flying cars to digital drugs, robot friends to teleportation, GPS to mobile communicators, smart food to mitochondrial reproduction techniques,” has roots in science fiction (Bassett, Steinmueller, & Voss, 2013). The multitude of examples demonstrate that “science fiction and science ‘fact’ — science and technology innovation, policy, public knowledge, investment — are not two separate realities but are two entangled and overlapping fields” (p.1).

However, science fiction is more than a technophilic wellspring. Good science fiction presents “a fully realized, multidimensional vision, including not only the technological and scientific, but the psychological, cultural, moral, social, and environmental dimensions of future human existence. The real future will be an interactive synthesis of all these dimensions” (Lombardo, 2018, p.3).

During the American Civil Rights movements, Martin Luther King Jr. encouraged Nichelle Nichols to remain in her role as Lieutenant Uhura on *Star Trek* though she had considered leaving. To King, *Star Trek* and Nichols represented a brighter world with a more progressive social system — a vision of the future for the Civil Rights Movement, in which a black woman was judged solely on the content of her character. Later, Nichols was instrumental in reforming NASA’s hiring policy, and the recruitment of Sally Ride and Guion Bluford, NASA’s first female and first black American astronauts respectively (Klus, 2017).

Recently, organizers and activists wrote an anthology of “visionary science fiction and speculative fiction”, titled *Octavia’s Brood: Science Fiction Stories from Social Justice Movements*. Paying homage to author Octavia Butler, they aspire to create “‘visionary fiction’ and movements for social change through short stories”. They believe science fiction “pulls from real life experience, inequalities and movement building to create innovative ways of understanding the world around us, paint[s] visions of new worlds that could be, and teach[es] us new ways of interacting with one another” (Brown & Imarisha, 2015).

In this context, science fiction empowers marginalized voices, fosters equal representation, and challenges entrenched orthodoxies and concepts of ‘the other’. The work of minorities and women has gained prominence and recognition in recent years, helping diversify the value systems depicted (owing partly to democratic reform at The Hugo Awards) (Liptak, 2017). As marginalized voices bring alternative perspectives to the genre, the perception of science fiction may shift from a plot-driven, artifact-centric genre to a socially conscious, value-centric one.

.....

The idea that science fiction can inform the design of a better tomorrow is becoming a movement. Recent initiatives such as *Project Hieroglyph* and The Verge’s *Better Worlds* both offered positive images of the future to inspire a better world (Konstantinou, 2019). They encapsulate the same spirit as Ray Bradbury’s *The Toynbee Convector* which posits that if someone shows us a brighter future and maps the path to it, we will all rush towards that outcome (Bradbury, 1984). Since positive images of the future are “one of the main instruments of culture, providing both a vision of civilization and the tools for realizing it”, the inclination to use science fiction in this manner should come as no surprise (Polak, 1973, p.13).

In stark contrast, Russia uses science fiction as a political weapon of war. Vladislav Surkov — a “political technologist” and “Putin’s grey cardinal” — allegedly writes science fiction under the pseudonym Natan Dubovitsky (Pomerantsev, 2014). Commentators pore over his dystopian visions of a non-linear war in order to understand the Kremlin’s vision for Russia (Komska, 2014). Surkov combined his background in public relations with his love of theatre and science fiction into a “strategy of power based on keeping any opposition ... constantly confused, a ceaseless shape-shifting that is unstoppable because it's indefinable” (Pomerantsev, 2011).

These examples demonstrate that science fiction offers an opportunity to imagine and prototype complex socio-economic and political systems of the future, and the reinforcing relationship people have with those systems (for better or worse). The genre will likely gain popularity as more real-world uses emerge.

## **An Entangled Relationship**

At present, “the divide between science fiction and futures studies is neither necessary nor desirable. There is a long history of crossover between the two, with each positively influencing the other” (von Stackelberg & McDowell, 2015, p.29). It was author H.G. Wells who first called for professors of foresight in 1932 (Wells in Slaughter, 1989, pp.3-4). Thirty-one years later, Arthur C. Clarke stated that “a critical . . . reading of science fiction is essential training for anyone wishing to look more than ten years ahead” (Clarke, 1963). Both Wells and Clarke, “frequently and successfully crossed back and forth from science fiction and futures studies” (von Stackelberg & McDowell, 2015, p.29).

Similarly, design and foresight reinforce each other. Whether we are designing products, policies, or services, time passes during the process, from the moment we identify a problem to the moment we implement a solution. In that sense, all design is for the future.

In *The Futures of Everyday Life*, Stuart Candy states that,

*Futures can lend design a richer temporal context and big-picture meaning-making... Design lends futures solidity, communicative as well as exploratory effectiveness... a direct interface to materiality, a place to begin pursuit of preferred futures in the concrete. Together, they provide the tools of a more complex and yet more intuitive exploration of possibilities, with the ‘theory objects’ of futures — which scenarios have always been — now assuming irresistibly tangible forms (2010, p.207).*

In science fiction, the overlap between foresight and design distills into a single concept deemed “the lifeblood of storytelling”: worldbuilding (Anders, 2013).

## **Worldbuilding**

Worldbuilding is the process of constructing a complete and plausible imaginary world that serves as a context for a story. It is “the creation of imaginary worlds with coherent geographic, social, cultural, and other features” (von Stackelberg & McDowell, 2015, p.32). Worlds “provide

detailed contextual rule sets that develop a larger reality that extends beyond a single story, while potentially providing a deeper understanding of the underlying systems that drive these worlds” (pp. 25-26). All stories require some worldbuilding, whether the story takes place in Rome in 500 B.C., or modern-day Tokyo, or in a galaxy far, far away.

Worldbuilding in science fiction can forge a stronger relationship between foresight and design because it is a form of social constructivism and systemic design. Similar to how our socio-ecological systems are emergent, co-evolved and “interlinked in never-ending adaptive cycles of growth, accumulation, [and] restructuring,” science fiction worlds instill a sense of completeness (Holling, 2001, p. 392). For example, Kim Stanley Robinson’s *Mars* trilogy begins with “humanity’s efforts to colonize our cosmic neighbor in Red Mars, and closes two centuries later in Blue Mars” having fully explored his “musings on science, politics, economics and religion” over hundreds of pages (Walter, 2016).

Heinlein’s *The Moon Is a Harsh Mistress*, Ursula Le Guin’s *Hainish* series, and Samuel Delany’s *Nova* are other examples of both science fiction and systems fiction because they attempt to portray how an entire society works rather than a fragment of it (Walter, 2016). Subgenres of science fiction such as climate fiction — which “explores the potential, drastic consequences of climate change” or alternative climates — also leverage systems-thinking<sup>2</sup> (Ullrich, 2015).

Worldbuilding is also an understudied act of intentional design. Raven and Elahi state that “little or no literature exists which applies the strategies and logics of narrative as understood by writers, cineastes and cultural scholars to the methods deployed by futures scholars and practitioners in the creation of their final outputs” (2015 p.49). Moreover, because narratives are processed differently than other forms of information, leveraging storytelling and worldbuilding may allow us to challenge societal values without antagonizing protected values.

## Worldbuilding, Foresight, and Design

The concept of worldbuilding is embedded within foresight and design practices, albeit to a different extent than it is in science fiction. Notable examples at this intersection include scenario generation, science fiction prototyping, experiential futures, and transition design.

### Scenario generation

Scenario generation has its roots in storytelling. The “RAND Corporation borrowed the Hollywood term scenario, referring to a movie script, to describe their work with military planners developing contingency plans” (Hammoud & Nash, 2014, p.2). Scenarios are a set of alternative futures that “describe a world to come, making a systematic set of assumptions about the drivers shaping that world. They may be brief and descriptive, or they may include story-like narratives that represent the point of view of personas in the future” (Institute for the Future, 2017). Foresight practitioners use several inductive and deductive methods to create scenarios including Generic Images of the Future, 2x2 Matrix, and Branch Analysis Method, amongst others (Bishop, Hines, & Collins, 2007).

Though scenarios are prototypes of the future designed for a variety of purposes, “their primary purpose is to guide exploration of possible future states” (Schultz & Curry, 2009, p.36). Scenarios are akin to worldbuilding because they describe future states. However, a “critique of existing scenario output is that too much of it consists of ‘snapshot’ scenarios, which merely describe the future conditions without explaining how they evolved” (Schultz & Curry, 2009, p.37; List, 2004). Compared to novels and films, they lack breadth and depth.

## Science fiction prototyping

Science fiction prototyping (SFP) is the systematic process of pulling science into narratives in order to generate technological prototypes and understand their human impact (Johnson, 2011). This method strategically mimics science fiction while leveraging the iterative, prototyping approach of design-thinking. SFP also leverages the interplay between worldbuilding and storytelling through the use of narrative, which scenarios sometimes lack.

Technology in science fiction is an aspect of worldbuilding because an artifact can exist across multiple stories (e.g. lightsabers are used in all *Star Wars* films). Since SFP aims to generate and understand the use of an artifact, it may fail to depict the broader system and the nuances and implications of those systems. It reinforces the idea that science fiction is most useful for product design and tech innovation, and ignores its potential for systemic design and future state prototyping.

## Experiential futures

Experiential futures are “situations and stuff from the future to catalyse insight and change” (Candy, 2015). Both it and SFP are closely related to speculative design. Speculative design places “new technological developments within imaginary but believable everyday situations that would allow us to debate the implications of different technological futures before they happen” (Dunne & Raby, n.d.). Speculative designs can be as simple as an unergonomic chair or “as substantial as a public transport infrastructure...At either end of the scale, the aim... is always to improve the future” (Kolehmainen, 2016).

Similar to SFP, the ‘stuff’ in experiential futures reflect worldbuilding, while the ‘situations’ are a blend of worldbuilding and storytelling, using story elements such as characterization and plot. Though it is more concrete than a scenario, experiential futures often depict instances within a broader world rather than a robust world. The method has one distinct advantage over science fiction: an experiential future brings a future into the real world, making it an immediate, firsthand encounter. Advancements in virtual and augmented reality may blur the lines between experiential futures and science fiction.

## Transition design

An emerging area of design that leverages science fiction, foresight, and systems thinking is transition design. It argues that we must go beyond social innovation, which “challenges existing socio-economic and political paradigms” and often lacks a long-term, systemic view (Irwin, Kossoff, Tonkinwise, & Scupelli, 2015, p.8). Instead, transition design calls for “radically new ideas and compelling visions of sustainable futures” that leverage “future-based narratives that come from the field of science fiction, narrative and storytelling, future-casting/futuring and speculative and critical design” (p.3). Similar to *Octavia’s Brood* and *Project Hieroglyph*, transition design aims to use science fiction to imagine brighter worlds and the pathways there.

Recent research in transition design yielded a worldbuilding model inspired by the work of science fiction authors, called *Seven Foundations* (Zaidi, 2017). It draws upon elements of foresight, design, and systems-thinking to provide a framework for creating new visions of the future using a first-principles approach. Both the model and the field of transition design are relatively new additions to the foresight and design landscape and warrant further exploration.

## Worldbuilding in Science Fiction

In science fiction, worldbuilding is expansive and elaborate, and the outcome is often a high fidelity product such as a novel or film. Unlike foresight and design, which are strategic practices

subject to real-world constraints (e.g. client objectives) and resources (e.g. time and money), the worlds of science fiction are a creative endeavor. A world may be constructed iteratively over years, or collaboratively assembled with robust support structures (e.g. films supported by studios). The result is richer and bigger worlds.

Science fiction gives us a world and story at once, depicting the broader context and implications of that context through plot and characters. It is this interplay between worldbuilding and storytelling that makes science fiction compelling as a strategic tool. According to Lombardo, “a good story about a possible future, with its drama, sensory detail, and nuances, is psychologically more compelling and realistic than an abstract futurist scenario or statistical prediction. Further, science fiction also personally draws us into a rich vicarious experience of the future through vivid and memorable characterizations” (2018, p.2).

Worldbuilding acts as a backdrop for emotionally resonant human experiences as well as the mundane, everyday life. When science fiction creators introduce us to new products, they depict the gestures and interactions required to use them, and moments when those products fail. When introduced to a new system, we see an alternative political reality, what it means to live within that reality, and possibly how to challenge that alternative status quo. The inner worlds and outer behaviours of characters provide filters for storyworlds. A scenario may introduce an artificially intelligent companion; science fiction depicts what it means to fall in love with it.

Though foresight scenarios may include ‘a day in the life’ vignettes, it is rare to see elaborate storytelling with a cast of characters. Neither do we see conversations between characters that explore the implications of the scenarios they occupy. Characters that reflect, interact with each other and the world, and engage in dialogue provide an accessible entry point into a world, along with multiple personas to navigate it. Situational experiential futures do capture some interplay between world and story. However, they are typically not documented and disseminated like science fiction is, limiting their real-world impact and opportunities for inspiration and deconstruction. Often, the conversation ends when the experience ends.

The worlds of science fiction also contain prototypes for complete and coherent systemic states, technologies, relationships, and values. The systemic nature of storyworlds allows us to repeatedly mine a world for new ideas and insights, with different stakeholders deriving different value. For instance, an entrepreneur may look to *Blade Runner* for product innovation, a transportation specialist for city planning, or a lawyer for human rights implications. Robust worlds provide endless strategic possibilities because they are difficult to exhaust.

## Borrowing from Science Fiction

More recently, foresight practitioners and designers are leveraging worldbuilding in new ways. For instance, *The Thing From the Future*, created by Stuart Candy and Jeff Watson, is a game that prompts “thought-provoking descriptions of hypothetical objects from different near, medium, and long-term futures” (Situation Lab, n.d.). The game may “yield close to 40,000 unique permutations in the redux edition (and over 3.7 million in the more complex, multivariate earlier version)” (Candy, 2018, p.238). Each permutation provides a scaffold for worldbuilding.

Alex McDowell, Director of the World Building Media Lab at the University of Southern California, uses worldbuilding and storytelling techniques both on and off screen. Recently, McDowell used worldbuilding techniques during a housing and sustainability development project on behalf of a Saudi Arabian foundation. The project looked “ten years into the future of a specific Bedouin tribe, a nomadic tribe who had been settled and fallen into abject poverty, with failing crops and decaying shelter” (McDowell, 2019, p. 109). This approach allowed members of the community to imagine alternatives “from sustainable housing to permaculture that establishes new and robust crops, [that] are all being implemented in the real world” (McDowell, 2019, p. 109).

Understanding the process of worldbuilding in science fiction can enrich design and foresight practice. Key concepts from science fiction authors that could influence design and foresight include designing for coherence, user testing worlds, and fostering a superstructure of culture.

### **Designing for coherence**

When science fiction authors like Ursula K. Le Guin create worlds, they ensure those worlds are coherent. Coherence implies that the design of a world has internal logical consistency. In an open letter titled “Plausibility in Fantasy”, Ursula K. Le Guin stated that:

*While I am composing I have no abstract ideas, purposes, or policies in mind, but am intent only on following the story . . . Then there is detail. The more realistic, exact, ‘factual’ detail in a fantasy story, the more sensually things and acts are imagined and described, the more plausible the world will be. After all, it is a world made entirely of words. Exact and vivid words make an exact and vivid world (Le Guin, 2005).*

Like Le Guin, when we design products, policies, strategies, etc., we too should aim to achieve coherence, ensuring that our designs and their details fit both with the current and emerging states of our world. For instance, are the products we create today coherent with the emerging realities of climate change? If not, what are the consequences?

### **User testing worlds**

Author N.K. Jemisin also strives for coherent worlds, but takes a different approach:

*Sometimes I’ll write a short story set in that universe to try and solidify my ideas. Not the same plot, not even the same characters; just playing around with the world. I call this a ‘proof of concept’ story, for lack of a better description — basically I’m testing the worldbuilding to see if it’s complete enough to support a novel yet. Often the act of writing the story helps me catch glaring holes in my worldbuilding (Jemisin, 2011).*

Personas and user journeys are staples of design work. In order to build robust worlds that we can mine for strategic purposes, we should test our designs and scenarios with multiple, diverging narratives. This includes understanding how different people (or personas) may approach our designs or scenarios, with consideration for extreme and/or unexpected users. Doing so may provide additional insights on how our designs and proposed future states will impact and influence people while mitigating unintended consequences.

It may also benefit us to explore how personas and user journeys might interact and influence each other. This may require prototyping and iterating conversations between various stakeholders, with the goal of generating diverse alternatives that allow for exploration, rather than a single refined outcome. For instance, what conversations may occur between entrepreneurs and government officials in the context of artificial intelligence in 2040? What happens when we filter those conversations through different emotions?

### **Fostering a superstructure of culture**

Authors William Gibson and Samuel Delaney have suggested that readers develop a “superstructure of culture on top of [an existing cultural construct] that allows them to enjoy” science fiction (Newitz, 2014). In other words, by engaging with alternative future worlds, science fiction readers develop an understanding of the modular, foundational components of a culture. They build their capacity to engage with alternative systems and ways of living.

Before we can design better futures for all, we have to build a societal-wide capacity to envision and design alternatives. This requires cultivating a multiple futures perspective while accounting

for the multiple perspectives that already exist in the present. Science fiction and futures-based narratives may help people develop a superstructure, and serve as a strategic precursor to widespread change. Creating more foresight-based narratives for various ages, and embedding information about complex problems within them, may prove beneficial.

Furthermore, it may be worthwhile to explore the role of narrative designers (individuals who design elements of story in games), and what such a role could play in society. If the Kremlin can employ a political technologist who uses science fiction to create chaos, how might we create roles and capacities that allow society to envision and realize collective preferred futures through storytelling? Could such a role help society foster a superstructure of culture and design for collective good? The concept of a cultural superstructure and the role of a narrative designer may have significant implications for both design and foresight, and warrant further exploration.

## Conclusion

The concept of worldbuilding in science fiction marries elements of foresight and design, and offers opportunities to enrich both practices. By understanding the many ways in which science fiction is used throughout society and borrowing from its worldbuilding processes, we may harness new insights on how to design emotionally resonant futures that inspire real-world action. Designing for coherence with emerging future states, user testing multiple, alternative worlds, and fostering a superstructure of culture may help strengthen the existing overlaps between foresight and design.

As researchers and practitioners, we should further explore of the worldbuilding processes of science fiction in order to design new, emotionally resonant visions of the future, and explore our place within those visions. Though the future looks precarious, a better world may be on the horizon if we work towards it.

## Correspondence

Leah Zaidi  
Independent Scholar  
Canada  
E-mail: leahzaidi@gmail.com

## Notes

1. Speculative fiction “includes fantasy, science fiction, and horror, but also their derivatives, hybrids, and cognate genres like the gothic, dystopia, weird fiction, post-apocalyptic fiction, ghost stories, superhero tales, alternate history, steampunk, slipstream, magic realism, fractured fairy tales, and more” (Oziewicz, 2017).
2. Based on an analysis of multiple definitions, “systems thinking is a set of synergistic analytic skills used to improve the capability of identifying and understanding systems, predicting their behaviors, and devising modifications to them in order to produce desired effects” (Arnold & Wade, 2015).

## References

- Anders, C. J. (2013, August 2). 7 deadly sins of worldbuilding. *Gizmodo*. Retrieved from <http://io9.gizmodo.com/7-deadly-sins-of-worldbuilding-998817537>
- Bassett, C., Steinmueller, E., & Voss, G. (2013). *Better Made Up: The Mutual Influence of Science fiction and Innovation*. Nesta Working Paper No. 13/07. Retrieved from <https://media.nesta.org.uk/document/nw1307>

nesta.org.uk/documents/better\_made\_up\_the\_mutual\_influence\_of\_science\_fiction\_and\_innovation.pdf

- Bishop, P., Hines, A., & Collins, T. (2007). The current state of scenario development: An overview of techniques. *Foresight*, 9(1), 5-25. doi:10.1108/14636680710727516
- Bradbury, R. (1984, January). The Toynbee convector. *Playboy*. Retrieved from <https://kwarc.info/teaching/TDM/Bradbury.pdf>
- Brown, A. M., & Imarisha, W. (2015). *Octavia's brood: The project*. Retrieved from <http://octaviabrood.com/index.php?page=the-project>
- Candy, S. (2010). *The futures of everyday life: Politics and the design of experiential scenarios* (PhD Dissertation). Department of Political Science, University of Hawaii at Manoa. doi:10.13140/RG.2.1.1840.0248
- Candy, S. (2015, November 2). La Chose du Futur à Paris [Blog post]. *The Sceptical Futuryst*. Retrieved from <https://futuryst.blogspot.com/2015/11/la-chose-du-futur-paris.html>
- Candy, S. (2018). Gaming futures literacy: The thing from the future. In R. Miller (Ed.), *Transforming the future: Anticipation in the 21st century*. New York: UNESCO / Routledge.
- Clarke, A. C. (1963). *Profiles of the future*. New York: Bantam.
- Delistraty, C. C. (2014, November 2). The psychological comforts of storytelling. *The Atlantic*. Retrieved from <https://www.theatlantic.com/health/archive/2014/11/the-psychological-comforts-of-storytelling/381964/>
- Dunne, A., & Raby, F. (n.d.). Design for debate. Retrieved from <http://www.dunneandraby.co.uk/content/bydandr/36/0>
- Gunn, E. (2014, May). How America's leading science fiction authors are shaping your future. *Smithsonian Magazine*. Retrieved from <http://www.smithsonianmag.com/arts-culture/how-americas-leading-science-fiction-authors-are-shaping-your-future-180951169/>
- Hammoud, M. S., & Nash, D. P. (2014). What corporations do with foresight. *European Journal of Futures Research*, 2(1). doi:10.1007/s40309-014-0042-9
- Harari, Y. N. (2015, June). *Yuval Noah Harari: What explains the rise of humans?* [Video file]. Retrieved from [https://www.ted.com/talks/youval\\_noah\\_harari\\_what\\_explains\\_the\\_rise\\_of\\_humans/transcript#t-398029](https://www.ted.com/talks/youval_noah_harari_what_explains_the_rise_of_humans/transcript#t-398029)
- Holling, C. S. (2001). Understanding the complexity of economic, ecological, and social systems. *Ecosystems*, 4(5), 390-405. doi:10.1007/s10021-001-0101-5
- Institute for the Future. (2017). Scenarios. Retrieved from <http://www.iff.org/what-we-do/foresight-tools/scenarios/>
- Irwin, T., Kossoff, G., Tonkinwise, C., & Scupelli, P. (2015). *Transition design* (Monograph). Pittsburgh, PA: Carnegie Mellon University School of Design. Retrieved from [https://design.cmu.edu/sites/default/files/Transition\\_Design\\_Monograph\\_final.pdf](https://design.cmu.edu/sites/default/files/Transition_Design_Monograph_final.pdf)
- Jemisin, N. K. (2011, December 14). Carving a new world [Blog Post]. Retrieved from <http://nkjemisin.com/2011/12/carving-a-new-world/>
- Johnson, B. D. (2011). *Science fiction prototyping: Designing the future with science fiction*. San Rafael, CA: Morgan & Claypool.
- Kaplan, J. T., Gimbel, S. I., Dehghani, M., Immordino-Yang, M. H., Sagae, K., Wong, J. D. ... Damasio, A. (2017). Processing narratives concerning protected values: A cross-cultural investigation of neural correlates. *Cerebral Cortex*, 27(2), 1428-1438. doi:10.1093/cercor/bhv325
- Klus, H. (2017). Imagining the Future: Why Society Needs Science Fiction. The Star Garden. Retrieved from <http://www.thestargarden.co.uk/Why-society-needs-science-fiction.html#Ref4>
- Kolehmainen, I. (2016, April 5). Speculative design: A design niche or a new tool for government innovation? *Nesta*. Retrieved from <http://www.nesta.org.uk/blog/speculative-design-design-niche-or-new-tool-government-innovation>

- Komska, Y. (2014, April 15). Can the Kremlin's bizarre sci-fi stories tell us what Russia really wants? *Pacific Standard*. Retrieved from <https://psmag.com/social-justice/can-kremlins-bizarre-sci-fi-stories-tell-us-russia-really-wants-78908>
- Konstantinou, L. (2019, January 15). Something is broken in our science fiction. *Slate / Future Tense*. Retrieved from <https://slate.com/technology/2019/01/hopepunk-cyberpunk-solarpunk-science-fiction-broken.html>
- Le Guin, U. K. (2005). Plausibility in fantasy. Retrieved from <http://www.ursulaklequin.com/PlausibilityinFantasy.html>
- Liptak, A. (2017, August 11). Women swept nearly every category at the 2017 Hugo Awards. Retrieved from <https://www.theverge.com/2017/8/11/16127310/2017-hugo-awards-n-k-jemisin-science-fiction-fantasy-books>
- List, D. (2004). Multiple pasts, converging presents, and alternative futures. *Futures*, 36, 23-43. doi:10.1016/S0016-3287(03)00140-X
- Lombardo, T. (2018). *Science fiction: The evolutionary mythology of the future Vol. 1*. Alresford, UK: Changemakers Books.
- McDowell, A. (2019). Storytelling shapes the future. *Journal of Futures Studies*, 23(3), 105-112. doi:10.6531/JFS.201903\_23(3).0001
- Newitz, A. (2014, November 10). William Gibson on the Apocalypse, America, and The Peripheral's ending. *io9*. Retrieved from <http://io9.gizmodo.com/william-gibson-on-the-apocalypse-america-and-the-peri-1656659382>
- Oziewicz, M. (2017). Speculative fiction. *Oxford Research Encyclopedias: Literature*. Retrieved from <http://oxfordre.com/literature/view/10.1093/acrefore/9780190201098.001.0001/acrefore-9780190201098-e-78> doi:10.1093/acrefore/9780190201098.013.78
- Polak, F. (1973). *The image of the future* (E. Boulding, Abr. & Trans.). Amsterdam: Elsevier.
- Pomerantsev, P. (2011). Putin's Rasputin. *London Review of Books*, 33(20), 3-6. Retrieved from <https://www.lrb.co.uk/v33/n20/peter-pomerantsev/putins-rasputin>
- Pomerantsev, P. (2014, November 7). The hidden author of Putinism. *The Atlantic*. Retrieved from <https://www.theatlantic.com/international/archive/2014/11/hidden-author-putinism-russia-vladislav-surkov/382489/>
- Raven, P. G., & Elahi, S. (2015). The new narrative: Applying narratology to the shaping of futures outputs. *Futures*, 74, 49-61. doi:10.1016/j.futures.2015.09.003
- Schultz, W., & Curry, A. (2009). Roads less travelled: Different methods, different futures. *Journal of Futures Studies*, 13(4), 35-60. Retrieved from <https://jfsdigital.org/wp-content/uploads/2014/01/134-AE03.pdf>
- Situation Lab (n.d.). *The Thing From The Future*. Retrieved from <http://situationlab.org/project/the-thing-from-the-future/>
- Slaughter, R. (1989). *Studying the Future*. Melbourne: Australian Bicentennial Authority / Commission For the Future. Retrieved from [https://foresightinternational.com.au/wp-content/uploads/2015/09/Wells\\_Wanted\\_Profs\\_of\\_Fsight\\_1932.pdf](https://foresightinternational.com.au/wp-content/uploads/2015/09/Wells_Wanted_Profs_of_Fsight_1932.pdf)
- Tavakoli-Far, N. (2013, July 23). Jules Verne to Star Trek: Does sci-fi show the future? *BBC News*. Retrieved from <http://www.bbc.com/news/business-23169444>
- Toffler, A. (1970). *Future shock*. New York: Random House.
- Tweney, D. (2011, May 25). May 25, 1945: Sci-fi author predicts future by inventing it. *Wired*. Retrieved from <http://www.wired.com/2011/05/0525arthur-c-clarke-proposes-geostationary-satellites/>
- Ullrich, J. K. (2015, August 14). Climate fiction: Can books save the planet? *The Atlantic*. Retrieved from <https://www.theatlantic.com/entertainment/archive/2015/08/climate-fiction-margaret-atwood-literature/400112/>
- von Stackelberg, P., & McDowell, A. (2015). What in the world? Storyworlds, science fiction, and

..... futures studies. *Journal of Futures Studies*. doi:10.6531/JFS.2015.20(2).A25

Walter, D. (2016, June 24). Systems fiction: A novel way to think about the present. *The Guardian*. Retrieved from <https://www.theguardian.com/books/2016/jun/24/systems-fiction-a-novel-way-to-think-about-the-present>

Zaidi, L. (2017). *Building brave new worlds: Science fiction and transition design* (MDes thesis). OCAD University. Retrieved from <https://www.researchgate.net/publication/321886159>



# SPACECRAFT: A Southern Interventionist Art Project

Ralph Borland  
Independent Artist and Curator  
South Africa

---

## Abstract

*“SPACECRAFT” is an interventionist art project in Southern Africa. This paper by the artist situates the work in relation to currents in futures studies and design. It puts these fields in conversation with interventionist art, and demonstrates their areas of overlap: their use of objects designed to have both immediate functions for a user and communicative functions to audiences; their critical response to social issues; and their futures-oriented approaches to transformative action. The paper points to the Southern location of this project, relating this to perspectives in futures studies on non-western futures.*

**Keywords:** Discursive Design, Futures Action Research, Guerrilla Futures, Interventionist Art.

---

## Introduction

A common sight in Southern African cities<sup>1</sup> is that of ‘wire artists’ plying their trade in public places. These are men<sup>2</sup> who make by hand and sell largely ornamental objects in galvanised steel wire, a common hardware product. The wire-frames they make are often combined with coloured-glass beads, and depict subjects such as animals, fish, birds, flowers, cars, bicycles, and aeroplanes. These products are offered for sale to passersby – frequently to motorists at busy traffic intersections. Making and selling wire art is a means of income for these men, in a country with very low levels of formal employment.

As an artist who grew up in South Africa and Zimbabwe, and who works now in Cape Town, South Africa, my attention has been drawn to these informal artists who practice in public space. The art form itself is resourceful and ingenious – it takes a cheap and available material, that is almost two-dimensional (a line) and makes complex three-dimensional forms from it. It attracts my attention in that it’s a form of public art – art which lives not in a gallery, but in the street. This chimes with contemporary art practices that seek to bring art into everyday space – such as interventionist art, explored in this paper.

Interventionist art characteristically looks for systems in society into which it can insert itself to further its ends – a tactical approach to expanding an art work’s reach by using what is already there. Street wire art presents possibilities here too: through years of observation I’ve noticed the way that wire artists replicate each others work. Forms persist, appear and diffuse through the wire art ‘scene’. Some new forms derive from popular culture, such as clown fish from *Finding Nemo*, or characters from the movie *Cars*. I imagined that this system might be able to carry my interventions, and proliferate them if successful.

In 2013 I began engaging with street wire artists, first commissioning wire art pieces to my design to create prototypes for new forms, and then conducting workshops in which wire artists could devise their own works within a framework set out by the project. This mix of commissioning, collaborating and co-designing, with the work we make shown on exhibition, has continued. In the years since I've worked with wire artists across Southern Africa and further afield in Brazil, where they have a similar wire art scene, and exhibited work locally and in Europe and Canada.

In this paper, I'm interested in bringing the lens of futures studies to bear on this project that seeks to influence the future development of the wire art scene. I have a multi-disciplinary academic background, spanning fine art, interactive telecommunications, design critique, development and science and technology studies. My post-doctoral work at the University of Cape Town focused on North-South knowledge inequalities and advanced the idea of 'Southern agency' (Borland, Morrell, & Watson, 2018). I am an independent artist, curator and interdisciplinary knowledge worker.

In the following sections I describe my work with wire artists, locating it within interventionist art practice, and then viewing it through the lenses of futures and design.

## SPACECRAFT as Southern Art Intervention

The two projects with which I engage with wire artists are *African Robots* and *SPACECRAFT*. *African Robots* focuses on the use of simple electronics to create interactive 'automatons' depicting local living creatures (Figure 1), *SPACECRAFT* on the production of wire-frame spaceships. This paper examines *SPACECRAFT*, with some reference to *African Robots*. The two projects collaborate: our latest work, titled *Dubship I – Black Starliner* is a large-scale wire art spaceship with an electro-mechanical sound system, installed in the Zeitz Museum of Contemporary African Art in Cape Town in April 2019.



An inspiration for both projects is the similarity between ‘old-school’ computer-graphic ‘wire frame’ and the hand-made three-dimensional forms produced by wire artists – often using only a single strand of wire. An aesthetic ‘hook’ for the project is to reinforce the congruency between something digital and something hand-made. The use of wire frame aesthetics plays on nostalgia for a past technological era – such as the 1984 *Star Wars* arcade game which uses colour wire frame graphics. The project’s first subjects are the iconic ships from the original *Star Wars* movies (Figure 2).

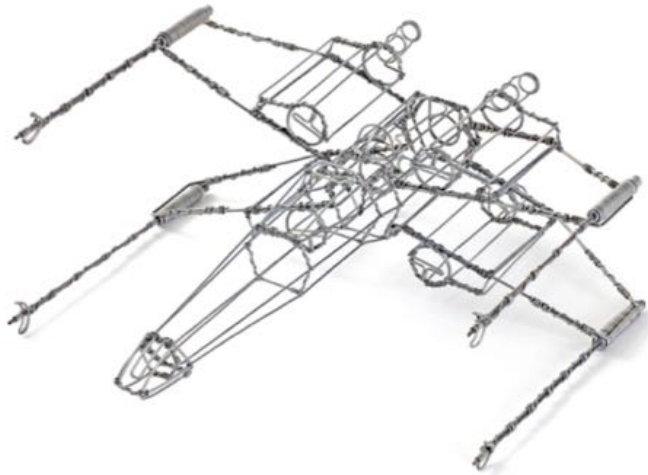

Figure 2. SPACECRAFT XW01 (2018). Photograph by SPACECRAFT

*SPACECRAFT* started in November 2015 in collaboration with a small group of wire artists, watching the first *Star Wars* movie and using freely available 3D models as references. We exhibited the work at street fairs and small exhibitions, and made personal sales to friends and contacts. Over time I produced graphics based on the sculptures, including T-shirts, banners and fine art screenprints, high-resolution photographs, an Instagram account @spacecraft.africa which shows the chronological development of the project, and most recently an interactive arcade game cabinet display. My intention is to set up an online store to sell the work we make.

The project has not yet succeeded in having the production and sale of these wire-frame spaceships catch on at street level. There have been isolated incidents, but not significant signs of interest from either wire artists in making more spaceships on their own account, or of street buyers in purchasing them. This is a problem partly of the design of the project – I’ve wanted to build the profile of the project, maintaining quality control of the quite technical work produced, and I haven’t explicitly focused on trying to make it spread. All work with wire artists has been paid for – I’m conscious of the vulnerability of these subsistence artists. For wire artists to risk their own time in making complex new designs with an unknown market for them seems to not yet be realistic.

Instead our focus has been on demonstrating the idea in exhibition forums, and attracting attention through the press, which has been successful. The project has received funding, principally from our National Arts Council in South Africa, which has enabled the development and exhibition of work. There is some irony in a project which took as its inspiration the public, everyday setting for wire art as opposed to the gallery, then finding its main place in galleries and formal exhibition forums. This is perhaps part of the journey of the project, to demonstrate the project in more conventional settings, and once its attraction to a public is demonstrated, for it to trickle back to the street-level settings which inspired it – when wire artists may have a reason to imitate the designs in order to meet a demonstrated market.

I locate *SPACECRAFT* in the field of interventionist art practice because of its engagement with a real-world, everyday phenomenon, which it makes the material of an artwork. Interventionist art has a strong engagement with ‘the everyday’, eschewing representation for action, and is often activist in its intentions: art for “the creative disruption of everyday life” (Thompson & Sholette, 2004). Rooted in the European Situationist art actions of the early 20th century, it follows a trajectory into activist, media-engaged art of the 1980s, ‘90s and 2000s, largely in Europe and the US.

The intention of *SPACECRAFT* to insert a novel material element into a system to benefit a marginal social group is a mode of interventionist art – see for example Michael Rakowitz’s project *paraSITE* (1997 – ongoing) which supplies custom shelters, that attach to waste hot air ducts from buildings’ heating systems, to homeless people in the US. A touch-point for *SPACECRAFT* is a series of interventionist works by the artist Cildo Meireles that responded to the restriction of information and communication in 1970s Brazil under military dictatorship. In his work ‘Insertions into Ideological Circuits’ (1970), Meireles identified systems in society that could carry messages critical of the establishment. He printed messages onto recyclable Coca-Cola bottles, putting them back into circulation bearing instructions for a Molotov cocktail, for example – a neat *détournement*<sup>3</sup> of the bottle (Barnitz, 2001).

I think of interventionist art as having particular application in Southern<sup>4</sup> situations such as that Meireles was operating in. The resourceful way in which interventionist art practice looks to available systems to leverage their impact to critical ends seems appropriate to parts of the world with high levels of inequality and lesser resources. Its identification with the less powerful, and its use of guerrilla tactics to direct benefits to them, while necessary everywhere, seems fitting to the history and context of the South.

The choice of *Star Wars* as subject matter for *SPACECRAFT* is tactical, and typical of some Southern approaches to power and “the [contested] trend towards the universalisation of western culture” (Sardar in Inayatullah & Boxwell, 2003, p. 251). *Star Wars* is a long-standing pop cultural phenomenon with high visibility, and a current wave of new products, whose market we might tap into. *Star Wars*’ origins in the late 1970s and 1980s lent itself to the nostalgic use of digital ‘wire-frame’ aesthetics that fitted this wire art project. The origins of African wire art lie in the depiction of new technological elements in Southern locations, largely vehicles such as trucks and cars made by children (V&A Museum of Childhood, 2016).

In adapting this material from *Star Wars*, we produced something new: an Africanised vision of spacecraft. Appropriation and adaptation of imported material is a feature of Southern sites. One of the frames for this is the idea, proposed by the Brazilian writer Oswald de Andrade in 1928, of ‘anthropophagy’ – cultural cannibalism – in which imported cultural products are consumed and made part of the body of the Southern host. De Andrade’s manifesto inspired the Tropicália or ‘tropicalismo’ artistic movement in Brazil in the 1960s, which especially in music combined local and foreign influences, the popular and avant-garde, with “a carnivalesque collective activism, one that has parallels in certain “interventionist” political art today” (Cotter, 2006). These movements aimed to identify agency rather than passivity in the consumption and use of Northern products by Southern sites, and the possibility for new forms to arise from their interaction.

One of the artworks produced by *SPACECRAFT* is a series of silkscreen posters, which depict the spacecraft against backdrops of manipulated wax-print patterns. African wax-print fabric is a leitmotif for the possibilities for ‘turning around’ the meaning of cultural products: while largely identified as an expression of particularly West African identity, it was designed and printed in Holland in the late 1800s, and intended for the Indonesian market as an imitation of their hand batik work. It wasn’t well-received by its intended market, but was hugely popular when sold in West Africa, where the designs acquired their own local meanings, and inspired local versions of wax-print. The most desirable wax-prints today are still produced by the originating company Vlisco in the Netherlands.

This appropriation and adaptation of imported forms is one of the mechanisms by which the South survives the marginal position given it by history and geopolitics – neither capitulating nor rejecting but tactically and creatively engaging. In *SPACECRAFT*, we insert ourselves into the *Star Wars* universe as much as we bring its forms into our practice.

## Design and Futures

Some overlaps between interventionist art, design and futures are already established. Interventionist art centred on the creation of new functional objects has been curated together with practical and speculative design objects in exhibitions such as *SAFE* (at the Museum of Modern Art in New York, 2005), *The Interventionists* (at the Massachusetts Museum of Contemporary Art, 2004) and *Return to Function* (at the Madison Museum of Contemporary Art, 2009). The concerns of interventionist art to communicate to audiences while equipping users intersects with areas of design similarly concerned with communication to audiences through the design of functional objects. These areas include critical design, interrogative design and design fiction; an umbrella term for these design approaches concerned with critical communication is ‘discursive design’, proposed by Bruce and Stephanie Tharp (2009).

Interrogative design in particular is a close cousin to interventionist art. Krzysztof Wodiczko, an artist-designer-academic whose seminal series of ‘Critical Vehicles’ included a cart for homeless people in 1980s New York, founded the Interrogative Design Group (IDG) at MIT. Rakowitz, a student of the IDG, exemplifies this union of design and intervention in everyday life with *paraSITE*. Stuart Candy describes interrogative design as a form of discursive design that, like interventionist art, operates “in the wild” in contrast to critical design which is often confined to the gallery (2010, p. 177). Candy has established the potential links between interventionist tactics such as détournement and futures work in his PhD thesis *The Futures of Everyday Life* (2010). Where interventionist art creates novel functional objects, it contributes, along with discursive design, to the field of ‘experiential futures’ outlined by Candy and others, which makes use of designed objects as props in imagined future scenarios – an area of activity in which art, design and futures intersect.

Interventionist and discursive projects across art and design fields have in common a focus on generating awareness of and discussion around social issues, more so than on the direct impact of the project on changing the immediate situation through design. For *paraSITE* for example, Rakowitz was explicit about the limits of his intervention: “it is very much an intervention that should become obsolete. These shelters should disappear like the problem should. In this case, the real designers are the policymakers” (Antonelli, 2005, p. 68). This may mean that the impact of such projects may be hard to measure – they are in harder-to-track indices such as increasing public or policy-maker awareness of an issue, often aimed at through attracting attention in the press.

Part of how *paraSITE* agitates is by presenting imaginative visions of the future, amplified by this intervention: the “relationship of these devices to the buildings” writes Rakowitz, “elicited immediate speculation about the future of the city... would these things completely take over, given the enormous number of homeless in our society? Could we wake up one morning to find these encampments engulfing buildings like ivy?” (Rakowitz, n.d.) In my work with wire artists for *SPACECRAFT*, we are presenting an image of the future of the wire art scene – now limited in scope, but showing what new products are possible in creatively applying available materials and processes. Its achievements so far have largely been in generating public awareness, through exhibitions and articles in the press, about these possibilities.

Taking a broader view of futures studies, Jose Ramos identifies the five main stages of development of the futures field: Predictive, Systemic, Critical, Participatory, and Action oriented – the latest with its “emphasis on action-oriented inquiry, associated with design, enterprise creation,

innovation, and embodied and experiential processes” (2017, p.826). Each of these stages of development of the futures field relies on the previous stages.

The vision of the future desired by *SPACECRAFT* was of street wire artists spontaneously making and selling science-fiction spaceships made in wire-frame style, inspired by the examples produced with my input, and spreading to other artists not involved in the project. I imagined in my normal journeys around the city seeing wire artists at traffic intersections holding wire-frame spaceships up for sale, and I imagined the pleasure and interest of the public in buying these new wire art products from street vendors.

From the Predictive stand-point, this vision of the future was not realised. It may still be, through finding a different route to this vision: by first establishing a market for these products away from the street through online sales, and sales in institutions. Echoing the project’s relationship to the *Star Wars* franchise, *SPACECRAFT* would be imitated by street wire artists because there is a demonstrated market for it. From the project’s perspective as interventionist art, it would then have succeeded in catalysing change in the real situation.

From a Systemic perspective that acknowledges complexity and indeterminacy through the envisaging of alternative futures (and with the benefit of hindsight) this alternative future for the project could have been predicted as a route to our goal: first establish a more formal ‘business’ that will demonstrate success and attract imitation. Part of how this and other alternative futures for the project could have been discovered is through asking wire artists to imagine alternative futures for the project – how might they have seen the project developing? Might this have been one of the mechanisms we could have predicted?

Critical studies of futures acknowledges the influence of different cultures, perspectives, discourses, and interests on visions of the future, including “whether they were from a “developing” or “developed” world perspective” (Ramos, 2017, p.826). *SPACECRAFT*’s depiction of *Star Wars* spaceships in a vernacular African wire art style inserts Africans into the fictional universe of *Star Wars*: the ‘explanation’ for these wire art depictions is that wire artists are seeing and representing space ships in their environment, as trucks and cars are already depicted – so wire artists are imagined as present in and Africanising the fictional world of *Star Wars*.

Ziauddin Sardar makes the claim that “the future has been colonised”; that “it is already an occupied territory whose liberation is the most pressing challenge for the people of the non-west if they are to inherit a future made in their own likeness” (Inayatullah & Boxwell, 2003, p. 247). What *SPACECRAFT* might suggest is that one mode for liberating the future is by infiltrating the hegemonic cultural products of the west through making modifications and insertions to them. This is not total liberation and substitution with completely alternative content, but it follows in the mode of Southern liberation in being tactical, adaptive and resourceful in ‘infecting’ the mainstream future – inserting itself into its ‘ideological circuits’.

When Sardar writes about globalisation’s tendency to “erode non-western, local traditions and cultural practices” (Inayatullah & Boxwell, 2003, p.251) it is worth bearing in mind that wire art, though now in part iconically ‘African’, is a hybrid cultural form, making use of a technology from the North, imported through colonialism and globalisation, but made to serve local forms of expression. Wire art is used by children as a way of supplying their own toys and possessing desirable technological imports, and later to make a living by adult artisans. Some forms of wire art, such as woven telephone-wire baskets made in Kwa-Zulu Natal in South Africa, involve direct substitution of plant material by wire using otherwise ‘traditional’ processes. In this way hybrid elements of Northern and Southern origin are woven together.

The latest *SPACECRAFT* work *Dubship I – Black Starliner* (2019) incorporates a broad swathe of technological history with a particular nod to non-western sources. It made use of the latest Virtual Reality sculpting tools, while incorporating a ‘piano roll’ device for driving the sound, which makes reference to both the automatic player pianos popular in the west in the 1800s, and to a much

earlier source: a design for a mechanical musical toy from the 12th century by the Islamic inventor Al Jazari, powered by a rotating drum with repositionable pegs. Al Jazari's design is acknowledged as one of the earliest instances of a programmable device – like the automaton and the piano roll, an influence on our current technological frontiers in computing (Nadarajan, 2005).

Afrofuturism, in which there is much contemporary interest, and whose themes intersect with *African Robots* and *SPACECRAFT*, presents visions of an alternative present or future in which technological pathways have been rerouted in ways appropriate to Southern settings, undermining a linear, Western concept of technological development. In complement to this mixing up of time, the fictional universe of *Star Wars* is set not in the future, but in the distant past. This implies a circularity of time in that the technology we are currently aiming for – space travel, the occupation of other planets, and so on – has already taken place. This is sympathetic to non-western concepts of time, and to the unsettling of futures for the west. As Sardar writes “for the west, the growth of Asia could mean a return to a future of a thousand years ago” (Inayatullah & Boxwell, 2003, p.258).

The Participatory futures mode, which offers “a pathway toward transformative action” through consultation and discussion, leads into the action mode that “emerges from embodied participation” (Ramos, 2017, p.827). From the perspective of the Participatory mode, *SPACECRAFT* has brought street wire artists into dialogue with diverse publics on a range of platforms. It might draw in a wider group of contributors to explore the possible futures for the project, from customers, to marketers and business advisors.

Futures Action Research – the mode with which *SPACECRAFT* seems most aligned – asks what coherence there is to be found in shared visions of the future amongst participants (Ramos, 2017). While the initial vision of the project for independent street-level production has not yet been realised, the common ground that has formed between myself as lead artist and instigator, and the wire artists I work with, is in enjoying the movement of wire art onto a range of different platforms and audiences beyond the street. The form the project has taken has responded to opportunity, and to finding out what wire artists themselves want to do. They have explicitly said that they like working on platforms which convey legitimacy for their work as art and that expand markets – in galleries, maker fairs, museums and pop-up spaces. Something for me to learn has been to challenge my romanticisation of the position of the street wire artist, and to acknowledge that a force on the project will be the desire of wire artists to move up from the street, rather than to just embrace change in their street practices.

Through participatory action processes such as collectively researching and working together, the project has made findings about wire art practices that demonstrate the complexity of both their business practices and hand-making approaches and skills. For example, one wire artist who sells his work on the street corner also receives pre-paid shipping boxes from a client in the US, to whom he sends work for sale there. The way in which wire artists conceive of three-dimensional form and how to describe it, often with a single unbroken piece of wire, indicates a complex grasp of topology, and has pointed the project towards the field of ethnomathematics, which identifies the complex mathematical principles that may be embodied in hand-made craft objects such as baskets – see for example the work of the late Paulus Gerdes, Mozambique (1999) and current proponent Ron Eglash, USA (1999).

Ramos identifies design and innovation as providing the potential for interventions he calls “seeds of change” “that can, over many years, grow to become significant change factors, leveraged for desirable long-term social change” (2017, p.824). He identifies “citizens and people from many walks of life” as having “the power to plant the seeds of change and create social innovations, alternatives, and experiments that provide new pathways and strategies that can lead to alternative and desirable futures” (2017, p.825).

Ramos' description of 'seeds of change' resonates with *SPACECRAFT*'s co-creation of small-scale designed objects that connect 'people from many walks of life' as a means for broader

social transformation. *SPACECRAFT* desires to make local and small-scale change in the world, and uses “design, enterprise creation, innovation, and embodied and experiential processes” as a means to do so (Ramos, 2017, p.826). The metaphor of a seed speaks to the potential for object-based interventions, and resonates with interventionist tactics for insertions – the seed as a small, functional object that will grow and develop, following the available gaps and opportunities in a system to extend its roots and branches, and potentially bear fruit.

## Conclusion

This paper explores *SPACECRAFT* as an example of a Southern interventionist art project that engages with an existing community of practice in an attempt to catalyse new aesthetic, social and economic possibilities, centred around the creation of new designed objects and the utilisation of existing networks to carry new material. *SPACECRAFT* has worked to spread awareness of wire art and the situation of wire artists through the exhibition of work and the attraction of interest by the press. The project indicates that possibilities for loosening the grip of the west in determining the future may involve recognising hybridity and creative appropriation as methods for ‘infecting’ western futures from the South.

The willingness of interventionist art to engage directly with live material, entering into everyday situations to shape outcomes, indicates that interventionist art, already overlapping with some areas of futures and design, might be a productive field for futures studies to further explore – and that futures perspectives might inform the tactics and outcomes of interventionist art. The most recent mode of futures research, Futures Action Research, seems of particularly appropriate application to this project.

One of the pivots around which all three fields described in this paper as possible frames for *SPACECRAFT* – interventionist art, discursive design, and futures action research – can turn is in their use of objects designed for both instrumental and communicative functions. The three fields are united by a critical take on society, in a desire for change, and a futures-oriented perspective for transformative action.

While so far unsuccessful in catalysing street-level production, the experience of new audiences and appreciation for their work on platforms away from the street has elevated wire artists’ sense of the potential for their work, as well as informing audiences. My engagement with street wire artists is not just an instrumental one for the creation of new products; the products are vehicles too for interpersonal engagement, for bridging social, economic and cultural divides, as well as those between art and craft, high art and low art, and high and low technology.

The South presents the challenge of creating relevance across striking contrasts in social, economic and cultural futures. Futures Action Research may be one of the means of facilitating communication and shared objectives across divergent groups. *SPACECRAFT* mobilised art and design towards achieving its objectives, and in this paper the potential role of futures in helping to direct it is illuminated.

## Correspondence

Ralph Borland  
Side Street Studios  
48 Albert Road, Cape Town  
South Africa  
<http://ralphborland.net>  
E-mail: [ralph.borland@gmail.com](mailto:ralph.borland@gmail.com)

## Notes

1. The author has observed this directly in Cape Town, Johannesburg and Durban in South Africa; Maputo in Mozambique; and Harare in Zimbabwe.
2. Women make and sell other crafts, but in the five years the author has engaged directly with wire artists in Southern Africa, he has never observed a women participating in this specific activity.
3. To turn around the meaning of a symbol – a classic Interventionist tactic (Thompson & Sholette, 2004).
4. This paper uses the term Southern to describe a set of relationships that could also be referred to as that between ‘western and non-western’ by Sardar (Inayatullah & Boxwell, 2003), centre-periphery or metropole and periphery (Connell, 2007), or ‘subaltern’ in Subaltern Studies. Following Connell (2007) the term Southern is used “not to name a sharply bounded category of states or societies, but to emphasise relations”, especially around authority, exclusion and inclusion, and hegemony. It refers to “an entire history of colonialism, neo-imperialism, and differential economic and social change through which large inequalities in living standards, life expectancy and access to resources are maintained” (Dados & Connell, 2012, p.13).

## References

- Antonelli, P. (2005). *SAFE: Design takes on risk*. New York: Museum of Modern Art.
- Barnitz, J. (2001). *Twentieth-century art of Latin America*. Austin: University of Texas Press.
- Borland, R., Morrell, R., & Watson, V. (2018). Southern agency: Navigating local and Ggobal imperatives in climate research. *Global Environmental Politics*, 18(3), 47-65. doi:10.1162/glep\_a\_00468
- Candy, S. (2010) *The futures of everyday life: Politics and the design of experiential scenarios* (PhD Dissertation). Department of Political Science, University of Hawaii at Manoa. doi:10.13140/RG.2.1.1840.0248
- Connell, R. (2007). *Southern theory*. Sydney: Allen & Unwin.
- Cotter, H. (2006, October 13). When a burst of sunshine swept over Brazil’s art world. *New York Times*. Retrieved from <https://www.nytimes.com/2006/10/13/arts/design/13trop.html>
- Dados, N., & Raewyn, C. (2012). The global south. *Contexts*, 11(1), 12-13.
- De Andrade, O. (1928), Manifesto antropófago (Cannibalist manifesto). *Revista de Antropofagia (Cannibalist Magazine)*, 1(1). São Paulo.
- Eglash, R. (1999). *African fractals: Modern computing and indigenous design*. New Brunswick, NJ: Rutgers University Press.
- Gerdes, P. (1999). *Geometry from Africa – Mathematical and educational explorations*. Washington, DC: The Mathematical Association of America.
- Inayatullah, S., & Boxwell, G. (2003). *Islam, postmodernism and other futures: A Ziauddin Sardar reader*. London: Pluto Press.
- Nadarajan, G. (2005). Islamic automation: A reading of al-Jazari’s The Book Of Knowledge Of Ingenious Mechanical Devices (1206). Paper presented at the REFRESH conference, First International Conference on the Media Arts, Sciences and Technologies at the Banff Center.
- Rakowitz, M. (n.d.). *Michael Rakowitz – paraSITE*. Retrieved from <http://michaelrakowitz.com/parasite/>
- Ramos, J. (2017). Linking Foresight and Action: Towards a Futures Action Research. In L. L. Rowell, C. D. Bruce, J. M. Shosh, & M. M. Riel (Eds). *The Palgrave international handbook of action research* (pp. 823-842). New York: Palgrave Macmillan.
- Tharp, B. M., & Tharp, S. M. (2009, January 5). The 4 fields of industrial design (No, not furniture, trans, consumer electronics, & toys). *Core77*. Retrieved from <https://www.core77.com/>

posts/12232/the-4-fields-of-industrial-design-no-not-furniture-trans-consumer-electronics-toys-by-bruce-m-tharp-and-stephanie-m-tharp-12232

Thompson, N., & Sholette, G. (2004). *The interventionists: Users' manual for the creative disruption of everyday life*. Cambridge, MA: MIT Press.

V&A Museum of Childhood (2016). Sign observed by the author. London, UK: Victoria and Albert Museum.

Wodiczko, K. (1999). *Critical vehicles*. Cambridge, MA: MIT Press.

# Are We (Really) Designing Futures? The Design of Tomorrow Program at CENTRO

Karla Paniagua  
CENTRO Advanced Design Institute  
Mexico

---

## Abstract

*This paper presents the preliminary results of a review of the first four years of the postgraduate course in Design of Tomorrow, which CENTRO Advanced Design Institute in Mexico City has offered since 2014. It assesses whether the program is achieving the aim of having students “design futures,” and to what extent the program conforms to the principles of foresight according to Wendell Bell. The question in the title is answered affirmatively, but with some important caveats, and areas of opportunity for improving the design of the program are identified.*

**Keywords:** Creative Economy, Design Education, Design Fiction, Foresight Programs.

---

## Introduction

In this paper we describe the process of creating and developing “Design of Tomorrow,” a one-year graduate program offered by CENTRO Advanced Design Institute since 2016, to train all kinds of professionals interested in designing and implementing possible, probable or preferable futures.

The focus here is evaluative, reflecting on a process that began as part of a renewal of curriculum that the institution considers as part of its best practices, and which also responds to the guidelines of the Ministry of Public Education of Mexico. CENTRO is currently preparing to become certified as part of the Federation of Mexican Institutions of Higher Education, so all curricula are in the process of improvement.

This article includes a description of the research process and the structure of the program, as well as a review of its preliminary results based on the evidence collected so far. Are our graduates designing futures? Are they capable of performing the crucial tasks of Futures Studies in the terms established by Wendell Bell? If not, what is needed to achieve this? These are the questions that will be answered in this paper.

For our purposes, the following definition from the Design Council (Mathers, n.d.) will be taken as a reference: “Design is what links creativity and innovation. It shapes ideas to become practical and attractive propositions for users or customers. Design may be described as creativity deployed to a specific end”, considering as its primary tasks framing, problem-solving, form, function, and style.

Next, the crucial tasks that for Wendell Bell (1997, p.111) represent the main purposes of Futures Studies are framed as questions here to make evaluation easier:<sup>1</sup>

1. Do graduates have the skills to study possible futures?
2. Do graduates have the skills to study probable futures?
3. Do graduates have the skills to study images of the future?
4. Do graduates know the foundations of Futures Studies?
5. Do graduates have the skills to study the ethical foundations of Futures Studies?
6. Can graduates interpret the past and orient the present?
7. Do graduates integrate knowledge and values for designing social action?
8. Do graduates have the skills to increase democratic participation in imaging and designing the future?
9. Do graduates have the skills to communicate and advocate a specific image of the future?

Bell's approach to Futures Studies was chosen to give intelligibility and inspiration to participants in the process: its broad trajectory is indisputable, so we can consider these principles to be representative (although without excluding other possible formulations) of the whole professional field.

CENTRO is an educational institution located in Mexico City, specialized in the training of professionals in the Creative Economy, a vibrant sector defined by inventiveness; for example in activities such as design, publishing, and digital media, among other activities that imply industrial or intellectual property.

For John Howkins, "a creative economy is a system for the production, exchange, and use of creative products. Economics deals with the problem of how individuals and societies manage to satisfy their wants, which are infinite and is primarily about the allocation of scarce resources" (2001, pp. 5-6). In this regard, CENTRO aligns all its study plans around their potential to contribute to a creative economy.

In 2014, the Research Coordination team of CENTRO was given the task of designing a new postgraduate course to bring the knowledge and skills of professionals from the creative industries to a new level. The Coordination team wanted the new experience to radically transform the way students would view reality, promote curiosity and imagination, involve research activities, and overall prepare graduates to face a changing world including an ability to address wicked problems:

*[S]ocial system problems which are ill-formulated, where the information is confusing, where there are many clients and decision makers with conflicting values, and where the ramification in the whole system are thoroughly confusing. The adjective "wicked" is supposed to describe the mischievous and even evil quality of these problems, where proposed "solutions" often turn out to be worse than the symptoms" (Churchman, 1967, p. B141).*

## The Design Process

CENTRO's research team conducted an extensive study to identify possible graduate courses that could take design to a new level of complexity. During this phase, the team identified and analyzed 46 national and international study programs, variously focused on developing creative skills to apply to business, public policy, and solving social problems.

This mapping exercise allowed the team to visualize the possible identity of the program for CENTRO, which would have solid methodological foundations in Futures Studies and Strategic Foresight, combined with creative tools that would allow effective communication of the outputs of the foresight process; both scenarios and the strategies to achieve them.

After selecting the most inspiring programs in this area, based on their practical aspects as well as their ability to create an intuitive spark, we performed a more detailed analysis of the following programs, mostly in developed countries (Table 1).

Table 1. *Programs included in the mapping phase*

Program	University	Country
Graduate Certificate in Future Studies	University of the Sunshine Coast	Australia
MDes in Strategic Foresight and Innovation MA, MDes, MFA in Digital Futures	OCAD University	Canada
MA in Future Studies	Freie Universität Berlin	Germany
Master in Futures Studies	University of Turku	Finland
MSc in Foresight and Innovation	University of Angers	France
MPhil Program in Future Studies	University of Kerala	India
Master in Strategic Foresight	Monterrey Institute of Technology and Higher Education	Mexico
MPhil in Future Studies	Stellenbosch University	South Africa
MSc in Foresight	University of Houston	United States
MA/Ph.D. in Alternative Futures	University of Hawaii	United States
MBA in Strategic Foresight	California College of the Arts	United States

Thanks to the Angers, Berlin, and Turku programs, we learned the importance of maintaining an ongoing dialogue with think tanks that gather experts around the world, both in order to receive specific feedback, as well as to maintain a network of professionals, mentors, lecturers and invited professors.

As a result of this understanding and with the purpose of studying their life trajectories, the team made contact with prominent Mexican futurists, some of whom also belong to national or international Futures Studies organizations: Margarita Arroyo (National Institute of Specialized Consulting); Guillermina Baena (World Future Studies Federation, Mexican Chapter); Antonio Alonso Concheiro (Analitica Consulting); Roger Aleph Mendez (Javier Barrios Sierra Foundation); Tomas Miklos (National Institute of Specialized Consulting); Alethia Montero; Concepcion Olavarrieta (Millennium Project, Mexican Chapter), and others, who later formed the Board of Advisors.

The history of Futures Studies in Mexico is closely related to these names. According to a history elaborated by Antonio Alonso Concheiro and quoted by Guillermina Baena (2009), the first specialized publications in the field date from 1948, although the boom started in the 1970s, with the creation of the Javier Barros Sierra Foundation (1975), the first center of Futures Studies in Mexico, led for many years by Miklos and Concheiro.

In 1994, the first foresight (*prospective*) Congress was held in the country, and later the production of specific content decreased, regaining momentum around the beginning of the millennium. The presence at a national level of organizations like the Club of Rome, The Millennium Project, and the World Future Society, as well as the fact that in 2019 the International Conference of the World Futures Studies Federation will take place in Mexico City, are signals of the current boom in the field.

The preceding allows us to contextualize CENTRO's interest in carrying forward the lessons of the foresight tradition in Mexico, as well as expanding the scope of the program through international connections with institutions such as Institute for the Future (California), from which we also receive advice.

During this stage, we realized that the concept of "Design Futures" was flourishing between multiple intersections — creativity and technology; science fact, design, and science fiction — and becoming a resonant buzzword in various Mexican cities, although in many instances the services offered under this denomination turned out to be superficial workshops referring to utopian or dystopian futures, without any strategic vision. This situation provided clear parameters around what we did *not* want to be.

At the same time, we asked ourselves: if those examples are not the Design Futures we wanted to teach, how should the course be formulated? Where and how should the intersections between Futures Studies and Design occur? We started the first edition of the program with a particular combination in mind, but for the second edition made adjustments, as will be seen later.

We also identified different continuing education efforts that offered the possibility of training individuals and organizations with interest in the skills and 'languages' of the future. These helped us understand the importance of accompanying the graduate program with short courses; for example, the Master Class in Design Futures of the Center for Advanced Design Studies of Monterrey (CEDIM) created by Stuart Candy and Jake Dunagan; the Strategic Planning: Foresight-Insight-Action workshop of the Institute for the Future; and the Futures Lab of the Extrapolation Factory.

This research process offered the team an opportunity to understand the vast and varied universe that constitutes Futures Studies, so we considered it fundamental that both the content of the classes and the profile of the team express this diversity.

The team defined as its deliverable a one-year postgraduate course (which in Mexico corresponds to the Specialty level, a degree prior to the Master's degree), in modules between four and eight weeks long, with both convergent subjects (methodology, trends, geopolitics, strategy), and divergent ones (e.g. narrative, laboratories of theater and sound experimentation, prototyping souvenirs from the future).

The first version proposed was rejected outright by the school authorities. Our advisors encouraged us to improve each specialty, making them different and unique, according to our students' needs.

Table 2 shows the original structure and revised (current) version of the study program.

Table 2. *Program structure*

Initial Structure (2015)	First Iteration (2016)	Second Iteration (2017-2018)
History of Futures Studies	History of Futures Studies	History of Futures Studies
Foresight methodology	Foresight methods and techniques, with an emphasis on DELPHI	Foresight methods and techniques, with an emphasis on Micmac and CLA analysis
Systems thinking	Systems thinking and change theories	Systems thinking and change theories, including analytical tools
Complexity theory	Foresight intelligence	Foresight intelligence and trend analysis
Big data and data mining	Disruptive innovation scenarios	Speculative design
Economics and geopolitics	Geopolitical Context	Geopolitical context and world order
Symbolic anthropology	Symbolic anthropology	Anticipatory anthropology
Narratives	Narratives for introducing scenarios	Multimedia narratives for introducing scenarios
End-of-course project	Constructing scenarios	Future sounds workshop
	Innovative strategic foresight planning processes	Strategic foresight planning processes
	Social innovation laboratory	Social innovation laboratory

It is worth mentioning that one relevant finding was the importance of accompanying postgraduate content with continuing education experiences, so simultaneously a futures study boot camp and a personal futures course were designed as immersive experiences for people interested in becoming familiar with the foresight language. These programs are still going on and have gained some independence from the graduate program.

The course curriculum was built around a core of three themes: Foresight methods and techniques; Design fiction, and a Social Innovation Lab.

### **Foresight methods and techniques**

The field includes a distinctive array of tools, instruments, and procedures, described for example in the manual of the Millennium Project (Glenn, 2009) and the Caja de herramientas de la prospectiva estrategica (Godet, 2000). On this basis, we selected vital resources taught and practiced throughout the program.

### **Design fiction**

For Bruce Sterling, science fiction and design constitute contemporary and parallel spheres which can enrich each other (2009, p.21):

*We have entered an unimagined culture. In this world of search engines and cross-links, of keywords and networks, the solid smokestacks of yesterday's disciplines have blown out. Instead of being armored in technique, or sheltered within subculture, design and science fiction have become like two silk balloons, two frail, polymorphic pockets of hot air, floating in a generally tainted cultural atmosphere.*

In Sterling's view, literature is a method of meaning and feeling, while design is a method of action: when combined, they give rise to creative responses, souvenirs from the futures that suspend disbelief (Bosch, 2012) and can facilitate a deep understanding of future scenarios, among other things.

According to Julian Bleecker (2009, p.7):

*Design fiction is a mix of science fact, design and science fiction. It is a kind of authoring practice that recombines the traditions of writing and storytelling with the material crafting of objects. Through this combination, design fiction creates socialized objects that tell stories – things that participate in the creative process by encouraging the human imagination.*

*The conclusion to the designed fiction are objects with stories. These are stories that speculate about new, different, distinctive social practices that assemble around and through these objects. Design fictions help tell stories that provoke and raise questions. Like props that help focus the imagination and speculate about possible near future worlds – whether profound change or simple, even mundane social practices.*

Why does design fiction play such an essential role in the program? Because it is here that future studies connect with the creative industries. In workshops to produce future objects at a one-to-one scale (Figures 1, 2), stories about future scenarios, or visualizations of critical data, students link their creative explorations with formal analysis. As such, the program offers students the methodological resources (storytelling, future theater, creative writing, modeling, data visualization) so that design fiction can lead to prototypes capable of “make-believe” (Dunne & Raby, 2013, p.90). To inspire interest among participants to head in a specific direction, either to bring about or to avoid a specific scenario.



Figure 1. Matilde Breña, *The Box of Life* (2018). This box is given by parents to their children in the Mexico of the future, when they turn 20 years old, so they can legally commit suicide. From Paolo Cardini's workshop, *Souvenirs from the Future*.



Figure 2. Alan Saenz, *Ovotril* (2018). In the Mexico of the future, the big pharmaceutical companies monopolize traditional medicine. *Ovotril* is a chicken egg to detect and heal the evil eye. From Paolo Cardini's workshop, *Souvenirs from the Future*.

## Social Innovation Lab

The application of foresight methods and techniques must focus on solving social problems, and the beneficiaries must be involved in devising solutions because they will play an essential role in their implementation. Therefore, throughout the program, students are encouraged to carry out fieldwork as participant-observers and conduct personal and group interviews, as well as workshops in which they apply their knowledge to release and direct collective intelligence.

As a complement to the fixed program, students attend international conferences with speakers who have shared with them their vision and experience, such as

Paolo Cardini (Rhode Island Institute of Design), Jim Dator (University of Hawaii at Manoa), Natalie Nixon (Figure 8 Thinking), Monika Bielskyte (All Future Everything), Gabriella Gómez-Mont (Laboratorio para la Ciudad), and José Ramos (Action Foresight).

We also have the collaboration of Jake Dunagan (Institute for the Future) as an international mentor, who visits each year to run an intensive experiential futures workshop to provide students with new tools and inspiration.

## Results

As of June 2019, the fourth generation of students in the graduate specialization completes their second semester of the program, while the fifth generation is preparing to begin.

So far, 39 students from various professions, 75% from the creative industries, have been enrolled; 82% of these have completed the total credits of the program, and 7% have completed the whole process to obtain the degree of Design of Tomorrow Specialist. In order to obtain a degree, students must select a topic, generate an analysis of signals and trends, apply one or several

foresight methods, design multiple future scenarios, and draw up a strategy for implementation to achieve the desired future.

To answer the question, “Are our students really designing futures?”, We examined a sample of term projects from the three first generations of the program. The selected projects meet the requirements, including analysis of context; detection of signals; study of trends; deployment of one or more foresight methods; several scenarios (in these first three years, focusing respectively on learning centers, distribution of wealth and social inequality); and a strategic proposal. One of these culminating projects has begun to be implemented, while the other two remain prototypes (Figures 3, 4).



Figure 3. Sandra Vargas’ final project workshop



Figure 4. Luis Daniel Mateos’ Term Project. Barter App Mockup

When we examine this portfolio of cases we observe in each one, in addition to fulfillment of all of Bell’s guidelines for a Futures Studies exercise, a creative quest to solve a problem or problem set; that is, an organized and systematic collection of design decisions.

In the intersection between science fact, design and science fiction, the students developed skills to design not the futures themselves (impossible in any case, according to Dator’s first law of the future<sup>2</sup>), but a series of futures narratives, visions, and souvenirs brought to the present, as well as systematic pathways to help build desirable scenarios. We do not have the certainty that our way of doing this exercise is the best, and of course it is not the only one, but it is undoubtedly a way of designing futures scenarios.

Considering this work in light of Bell’s principles, we see the following (Table 3):

Table 3. *Bell’s skills accomplishment for each term project*

Skills	Learning Centers Project	Wealth Distribution Project	Social inequity Project
1. Study possible futures	YES	YES	YES
2. Study probable futures	YES	YES	YES
3. Study images of the future	YES	YES	YES
4. Knowledge about the foundations of Futures Studies	NO	NO	YES
5. Study the ethical foundations of Futures Studies	NO	YES	YES
6. Interpreting the past and orienting present	NO	NO	NO
7. Knowledge and values for designing social actions	NO	NO	NO
8. Increase democratic participation in imaging and designing the future	NO	NO	NO
9. Communicating and advocating a specific image of the future	NO	NO	NO

In February 2019, a survey was administered to 26 graduates of the specialty, to gather their perceptions of their learning experiences, including knowledge and skills acquired.

From the total survey responses, 40% strongly agreed that they had learned a Futures Studies methodology, 30% agreed, and the remaining 30% was distributed equally among ‘neither agree nor disagree,’ ‘disagree’ and ‘strongly disagree’ (Graduate Students DTP, 2019).

Twenty per cent of the survey respondents strongly agreed that they had learned how to design futures, 50% agreed, 10% neither agreed nor disagreed, and 20% disagreed. Survey respondents strongly agreed that they applied the knowledge received in the specialty, 50% agreed, and the remaining 30% neither agreed nor disagreed.

Considering Bell’s principles, the complete survey provides the following overview (Table 4):

Table 4. *The accomplishment of Bell's Foresight Skills according to the graduates*

Skill	Percentage of respondents considered qualified to perform this task as a result of the specialty
1. Study possible futures	33%
2. Study probable futures	33%
3. Study images of the future	77%
4. Knowledge about the foundations of Futures Studies	11%
5. Study the ethical foundations of Futures Studies	33%
6. Interpreting the past and orienting present	55%
7. Knowledge and values for designing social actions	66%
8. Increase democratic participation in imaging and designing the future	22%
9. Communicating and advocating a specific image of the future	55%

## Discussion

The review of projects yielded clear evidence that the program does provide the necessary elements for students to be able to design future scenarios in different formats, including the strategies to achieve them. In contrast, the survey revealed that not all graduates recognize this skill in themselves: only 20% responded with strong agreement that they have this skill. A key opportunity for improvement appears to lie in metacognition, in a more conscious exercise of our graduates as real designers of future scenarios.

Does the program enable students to practice the principles of foresight enunciated by Wendell Bell? The project assessment showed that the program did indeed appear to train graduates capable of studying possible and probable futures, as well as future visions, but as the complexity of Bell's principles grows, the evidence of the principles' deployment decreases: such is the case for principles 5, 8 and 9. Our students need to work more systematically and deeply about ethical reflection, the democratic exercise of imaging and designing futures, and the defense of specific visions of futures; relatively complex tasks that demand more energy and time than others. To achieve this, we intend to update the curriculum, propose an association of program graduates, and have the fourth generation of students create a manifesto to represent the spirit of the Specialty, as a start.

In this regard the survey also revealed a gap between the institution's and the graduates' perceptions, the latter being more optimistic: For example, unlike the institution, 66% of graduates consider having knowledge and values to design social actions (Graduate Students DTP, 2019). This points to a potential need to involve students, graduates and teachers in the redesign of curriculum, in order to minimize biases and take advantage of different visions.

The results also suggest that the institution could benefit from closer contact with other national and international institutions that offer postgraduate Futures Studies. In the first years of the program to date, our focus regarding other institutions has been on learning from (identifying and analyzing the structure of) their curricula. However, now that the program has accumulated its own experience and we have something more to offer, we are perhaps better able to take part in an open dialogue to seek exchange, experimentation, and continuous improvement.

With each iteration, the program has changed (to improve meaningfully, we hope) the teaching and learning experience, technical content, overall vision, traction with potential stakeholders, teaching quality, and applicant selection methods. These improvements have brought new results including increasingly demanding students, and higher expectations of term projects. The term project and its implementation is always the critical point, devising a strategy geared towards the achievement of desired futures is the most complex task in the professional field.

We do not want our students to become experts in designing scenarios while neglecting implementation, because the exercise is not complete without a strategy, and the strategy dies without deployment. This is where we face the most significant area of opportunity: cases of implementation remain sparse at this stage.

Another critical subject is the possibility of expanding the program to a two-year Master's degree, since in the opinion of professors, our advisors, and graduates alike; the content is too substantial to be adequately studied and practiced in a single year. At the time of writing, we are analyzing this possibility and will make decisions shortly. In the immediate term, the curriculum is being updated completely, to incorporate the many lessons learned throughout the years to date.

## Conclusion

Following Dator's logic, just as the future can not be predicted because it does not exist, neither can it be designed instrumentally. That is, scenarios are a way to shape visions of the desirable future, without a doubt, but it will not be until the events occur (or not) that we can verify whether we "designed the futures," and we will not always be there to see it. That is the greatest irony of our work! In this light, the question "Are we really designing futures?" does not have a final answer.

What CENTRO students are undoubtedly designing, however, are future scenarios and strategies with a solid technical basis. The next step will be to ensure that their strategies have the opportunity to be tested and realized.

Another significant finding, although it escapes the scope of the question posed, is that the Specialty in Design of Tomorrow is changing the way CENTRO itself makes decisions. This happens subtly, but we have already noticed the first signs, for example, the inclusion of small scenario design courses in the last year of all undergraduate courses as a measure to improve the long-term vision and decision-making of our graduates.

We believe that there is not merely one precise or ideal intersection (the longed-for sweet spot) between Futures Studies and Design. Indeed, good foresight always involves design decisions; choices towards preferred outcomes are supposed to be integral. In our journey to find an institutional identity, we have found in our way that the design/futures relationship is very close and that the creative industries can naturally find a source of inspiration and strength in the exercise of foresight.

Our graduates have the skills to study possible and probable futures, and images of the future, as they put into practice the methods taught in the specialty, such as Micmac (Godet, n.d.), the Anticipatory Experimentation / Bridge Method (Ramos, 2017), and Ethnographic Futures Research (Textor, 1995). They know the basics of Futures Studies because they have a history class that specifically addresses that topic. They reflect deeply on the ethical implications of future design; as an illustration, the fourth generation held a workshop on the future of economic, digital and magical revenge using the Aspirational Futures model (Bezold, 2009). They confront the difficult task of interpreting the past and orienting the present and work hard to integrate the knowledge and values of the futures discipline into the design of social actions. They also face challenges in finding ways to increase democratic participation in imaging and designing futures, as well as communicating and defending a specific image of the future.

The problems that graduates meet in learning these principles are attributable in part to the structure of the program, which emphasizes the design of futures more than strategy and implementation, but also in part perhaps to the configuration of the field itself; a hypothesis that is a subject for more in-depth research.

After all, the most significant learning from this exploration is that both design and futures studies, although they evolved as autonomous fields, are crossed by multiple intersections, so perhaps it is precisely this shared condition of being intersecting, open fields, always unfinished, that allows them to flourish and complement each other naturally.

## Correspondence

Karla Paniagua  
CENTRO Advanced Design Institute  
Mexico  
E-mail: kpaniagua@centro.edu.mx & TW@cirila\_thompson

## Notes

1. These principles and questions were incorporated into the framework for improvement of the curriculum, and not in the original program design. Although included at a later stage, they proved very useful for giving a stronger direction to the graduate program.
2. "The future" cannot be "predicted," but "alternative futures" can, and should be "forecast." (Dator, 1995)

## References

- Baena, G. (2009). Sobre futuros incompletos y esperanzas continuas. Líneas para la historia de la prospectiva en México. En D. & Dos Santos, *Prospectiva Na America Latina. Evolucao e desafios* (págs. 210-233). Bauru: Canal 16 editora.
- Bell, W. (2005). *Foundations of Futures Studies*. London: Routledge.
- Bezold, C. (2009). Aspirational Futures. *Journal of Futures Studies*, 81-90.
- Bleecker, J. (17 de 03 de 2009). *Blog Near Future Laboratory*. Obtenido de <http://blog.nearfuturelaboratory.com/2009/03/17/design-fiction-a-short-essay-on-design-science-fact-and-fiction/>
- Bosch, T. (02 de 03 de 2012). *Future Tense*. Obtenido de [http://www.slate.com/blogs/future\\_tense/2012/03/02/bruce\\_sterling\\_on\\_design\\_fictions\\_.html](http://www.slate.com/blogs/future_tense/2012/03/02/bruce_sterling_on_design_fictions_.html)
- Churchman, W. (1967). Wicked Problems. *Management Science*, B141-B142.
- Concheiro, A. (2007). *La prospectiva en Iberoamérica, Encuentro Internacional de prospectivistas mexicanos "Desafíos futuros de Iberoamérica"*. NA: World Futures Studies Federation.
- Council, D. (10 de 04 de 2019). *Design Council*. Obtenido de Defining Design: <https://www.design-council.org.uk/news-opinion/defining-design-going-beyond-disciplines>
- Dator, J. (18 de 04 de 2019). *What Futures Studies Is, And Is Not*. Obtenido de <http://www.futures.hawaii.edu/publications/futures-studies/WhatFSis1995.pdf>
- Dunne, A. (2013). *Speculative Everything. Design, Fiction, and Social Dreaming*. Cambridge: The MIT Press.
- Godet, M. (18 de 04 de 2019). *La prospective*. Obtenido de Micmac: <http://es.lapropective.fr/Metodos-de-prospectiva/Los-programas/67-Micmac.html>
- Graduate Students DTP, C. (16 de 02 de 2019). Survey to Graduate Students. (K. Paniagua, Entrevistador)

- Howkins, J. (2001). *The Creative Economy. How People Make Money from Ideas*. London: Penguin.
- Mathers, J. (n.d.). Defining design: going beyond disciplines. *Design Council* website. Retrieved from <https://www.designcouncil.org.uk/news-opinion/defining-design-going-beyond-disciplines>
- Ramos, J. (18 de 04 de 2019). *Anticipatory Experimentation. Bridge Method*. Obtenido de <https://actionforesight.net/action-foresight-bridge-method/>
- Sterling, B. (2009). Design Fiction. *Interactions*, 21-24.
- Textor, R. (1995). The ethnographic futures research method: An application to Thailand. *Futures*, 461-471.



# A Futures-Design-Process Model for Participatory Futures

Stefanie A. Ollenburg  
Freie Universität Berlin  
Germany

---

## Abstract

*This paper presents a way of merging approaches of participatory futures research with the structures of Research through Design, to apply processes and methods from design in scientific research. It offers a systematic model to integrate the communication process used in human-centered design (i.e. the Generic Design Process) with concepts found in participatory normative futures studies and foresight practices. It is based on the understanding that design and foresight methodology have been converging for some time now, and acknowledges the branch in futures studies that has been employing creative approaches often to work on societal issues. This “Futures-Design-Process model” wants to offer a structure mainly for participatory futures research, towards generating knowledge as well as action to shape a more sustainable future.*

**Keywords:** Alternative Futures, Design Process, Futures Research Design, Participatory Futures, Research Through Design.

---

As a communication designer, futurist, and researcher my quest is to merge the scientific aspects of analysis and reflection with the momentum of the inspirational and creative facets of designerly knowing (Cross, 2006). When introduced to the theoretical debate on the paradigms of futures studies, the exploration of future developments often seem to involve normative participatory formats to discover the different images and concepts that stakeholders have (Bishop & Hines, 2013; Inayatullah, 2008; Kreibich, Oertel, & Wölk, 2011). The German futurist Rolf Kreibich defines the field as follows: “Futures studies are the *scientific* study of possible, desirable, and probable future developments and scope for design, as well as the conditions for these in the past and in the present. Modern futures studies assume that the future is not entirely determinable and that different future developments (futures) are possible and there is scope for design.” (Kreibich et al., 2011, p. 8, emphasis added)

The interdisciplinary field of futures studies intersects with the humanities, natural sciences, politics, and more recently, on a conceptual and methodological level, with design (Candy, 2010; Candy & Dunagan, 2017; Hines & Zindato, 2016; Kelliher & Byrne, 2015; Ollenburg, 2018). For example, in 2012 Arizona State University hosted “Emerge: Artists and Scientists Redesign the Future”. It had the aim to “... purposefully unite[] artists, designers, social scientists, futurists and engineers in an integrated series of foresight workshops

and activities” (Kelliher & Byrne, 2015, p.36). A more recent event was the “Design Develop Transform Conference” in Brussels and Antwerp in June 2017, hosted by the department of Applied Futures Research of the Erasmus University College Brussels and the Museum of Contemporary Art Antwerp. At this three-day event, contributors from all over the world presented their theories and approaches, often combining futures research, design and creative methods. In recent years design schools have understood that the act of design is planning and creating for a future, and started offering graduate studies in the field of futures studies and foresight practices, at OCAD University<sup>1</sup>, California College of the Arts<sup>2</sup>, and Potsdam University of Applied Sciences (FH;P)<sup>3</sup> among others (Candy & Dunagan, 2017, p.138; Ollenburg, 2018).

Already in the 1960s and 1970s approaches were developed to combine the anticipatory with the creative, of which Robert Jungk’s and Norbert Müllert’s Future Workshop methodology is an example. It was meant to encourage and empower participants to design their own future (Kuhnt & Müllert, 2006). Throughout the three phases of *critique* (critiquing the present situation) *utopia* (imagining the desired), and realization (setting up plans to implement), creative methods are applied to inspire and aid participants to visualize and think outside the box. Following suit are processes such as Action Research (Ramos, 2017) where stakeholders participate in research to actively find solutions to their issues. Such approaches have been criticized in some quarters as failing the requirement of scientific standards, and so rather work as consulting tools (Popp, 2013).

Nonetheless the breadth of work by futurists and designers, exploring ways to combine their fields and methods, has been growing rapidly (Candy & Dunagan, 2017; Hines & Zindato, 2016). This paper acknowledges their pioneering work (the present double issue of the *Journal of Futures Studies* on Design and Futures is itself a witness to this development). The combination seems a natural fit as both design and futures studies work with aspects of the future. Yet design often concentrates on the tangible, and futures studies on the imaginable and strategic (Candy, 2010; Hines & Zindato, 2016; Ollenburg, 2018).

Frameworks to combine the two – especially design methods and participatory formats – have been proven to work in transformative processes (Candy & Kornet, 2019; Ramos, 2013). Yet the question remains; is there a structure that can systematically enclose the concepts and methods derived from futures studies, utilize the inspirational momentum of design, and measure up to scientific standards of reproducibility and transparency?

In strategic foresight, Joseph Voros suggests the “Generic Foresight Framework” (Voros, 2003). As a structure that is clear, transparent, and linear, it could be said to meet scientific research standards – where process, distinct methodology, as well as the objective of each phase, support the evaluation of results and help to define the researcher’s role. Voros’ framework consists of the following phases: Inputs: look and see what’s happening → Analysis: what seems to be happening? → Interpretation: what’s really happening? → Prospection: what might happen? → Outputs: what might we need to do? And finally, Strategy: what will we do? / how will we do it?” (Voros, 2003, p. 11). If creative and design elements were added, at first sight this may seem a viable option for combining foresight and design in a structure for research projects. Yet it lacks the human-centered attitude that is inherent in the design process.

Searching further in the field of design methods, I came across the design theorist Wolfgang Jonas, who has examined design, its methods and process since the 1990s. He proposes a three-phase model as a communicative and iterative design process, consisting of Analysis, Projection, and Synthesis (Jonas, 1997, p.12). He finds parallels between scenario planning and designing, with the latter being a pragmatic aspect of futures studies (p.13-19).

Therefore, this paper explores the proposal for a “Generic Design Process” used in “Research through Design” (RtD) (Hugentobler, Jonas, & Rahe, 2004; Jonas, 2007) as a foundation for futures research that would integrate participatory foresight approaches without compromising the transparency and comprehension requirements of scientific studies. Its objective is to merge these

requirements with design's inspirational and practical facets, to open up the possibilities of making future developments into tangible experiences.

## Participatory Futures Research

In futures studies it is generally agreed that the *future* as a temporal phenomenon does not exist, is uncertain, and in this sense, that *the future* in itself cannot be an object of research. People do however envision futures and have their own images of them (Candy & Dunagan, 2017; Grunwald, 2014; Inayatullah, 2008). The concept of *future* can be an empty canvas, inspiring us to fill it with our hopes and fears, and due to ecological, economic and social challenges, the interest in getting more defined ideas on future developments is increasing. But in scholarly futures studies, an exclusively predictive orientation is widely seen as outmoded (Gidley, 2017; Ramos, 2017). Projects that deal with current and future challenges relevant to the public often actively involve stakeholders, addressees, as well as experts of a field. Participatory formats encourage the sharing of images, ideas, and concepts about the future to obtain a wide range of perspectives on possible developments (Hayward & Hines, 2012; Kreibich et al., 2011).

This participatory futures studies approach can be traced in part to roots in Germany in the late 1960s, in the epistemology of Critical Theory, with the aim of empowering the human being to shape their own future. Robert Jungk's Future Workshop comes from that era. Historian Elke Seefried calls this strand within the field "critical and emancipatory" (Seefried, 2014, pp.12-13). Further, the aim to involve and empower stakeholders in shaping their future is found in such methodologies as Action Research, where scientific research combines with practice-orientation towards social transformation (Gidley, 2017; Kreibich et al., 2011; Popp, 2013; Ramos, 2017). "[Participatory futures] facilitates empowerment and transformation through engagement and participation. Researchers have found that being able to participate in how the future is constructed by the powers-that-be is an empowering process" (Gidley, 2017, p.70).

To effectively engage stakeholders in envisioning their futures, and to encourage change, futurists have elaborated diverse methods and structures. Most include learning as the key to transformation (Dator, 2009; Inayatullah, 2008). The structure of "Anticipatory Action Learning" (AAL) is just one example that fuses participatory approaches and futures studies, and opens "a transformational space of inquiry, the long-term and planetary future, with the everyday and embodied world of relating and acting" (Ramos, 2017, p.830). Another is Inayatullah's "Six Pillars of Futures Studies", consisting of Mapping, Anticipating, Timing, Deepening, Creating Alternatives, and Transforming (Inayatullah, 2008; Ramos, 2017). Along similar lines is José Ramos' "Futures Action Model" (FAM). Its nested structure aims towards a problem-solution sequence based on the sociological method of Action Research, and it combines the participatory approach with futures research methodology. It starts with issues of global relevance to trickle down to "a solution space where participants can explore the purpose, resource strategy, and governance system of an initiative that can effectively address the issue or problem" (Ramos, 2017, p.837).

Participatory futures research is a normative and dialogical process in search of social transformation. Its objective is to interactively explore present images, ideas, and concepts of the future. It may want to deconstruct current concepts to give space to innovative ideas and encourage alternative paths (Dator, 2009; Inayatullah, 2008; Kreibich et al., 2011; Ramos, 2017). In research with participatory claims, a researcher holds a dual role: first, to explore and analyze, and second (for example in stakeholder-workshop formats), to become a facilitator for change. Under such circumstances, upholding scientific standards can become a dilemma: when and how to play the researcher, whose task is to keep track of and scrutinize data outside the normative influence of participants with their cultural structures, social patterns, and behaviors, and when to play the facilitator, whose task is to initiate transformation (Popp, 2013). The availability of a framework to

structure and divide the research design might aid the researcher/facilitator in managing these roles. It may perhaps make the process more transparent and reproducible, supporting the evaluation of results.

## Research Through Design

To design is to plan, create, and initiate change, and includes communicating with the user / stakeholders for whom an artifact is created. Therefore, to design is part of a communication process (Krippendorff, 2006, p.149). Even in a “technology-driven design”, the communication is from the designer who produced the artifact as the “expert for the layman”. Such “monological” communication can be called “first-order-understanding” (Krippendorff, 2006, pp.67-68). In contrast, but similar to the participatory futures approaches, in a “human-centered design process” the designer involves stakeholders. With this “dialogical” attitude there is space to exchange ideas and find acceptable compromises. As a communication process it extends beyond words where the designer appreciates the “network of stakeholders” (versus a “voiceless user”) and with them explores their needs and preferences<sup>4</sup> (pp. 64-65). “Understanding someone else’s understanding is an understanding of understanding, an understanding that recursively embeds another person’s understanding in one’s own, even if, and particularly when, these understandings disagree, contradict one another or are thought by one to be wrong or appallingly unethical. This recursive understanding of understanding is a *second-order understanding*” (Krippendorff, 2006, p.66).

To have an encompassing understanding of the stakeholder’s perspective, the human-centered-design-process combined with the designer’s way of knowing (i.e. process of trial and error as well as exploring options) is a type of design research (Cross, 2006, pp.29-34). Here design methods are combined with adaptations of methodologies from the social sciences, humanities, and the like (interviews, personas, customer journeys, cultural probes and more). They help make intangible ideas and concepts tangible: “Design research is a systematic search for, and acquisition of knowledge related to general human ecology considered from a designerly way of thinking, i.e. a project-oriented perspective” (Findeli, 2010, p.294).

Such dialogical design processes can be applied towards research *for* design, or *in* design, but also, as design theorist Christopher Frayling calls it, “Research *through* Design” (RtD). This means that the designer’s own instruments and methods are used to produce new information. Part of the research process is to create and work with tangibles and artifacts. This experience becomes relevant for theory-building as well as practice (Jonas, 2015b, p.34). It refers to research adapting a design process, designerly thinking, to acquire results and generate knowledge. “Design[erly] thinking is in many ways the obverse of scientific thinking. Where the scientist sifts facts to discover patterns and insights, the designer invents new patterns and concepts to address facts and possibilities” (Owen, 2007, p.17).

Similar to participatory futures research, the results of RtD often go beyond solving problems. In RtD the interaction can encompass unexpected discoveries and innovations. The critique of RtD is that scientific standards such as verifiability may not apply, and that the process may be too intuitive and insufficiently transparent, and therefore not reproducible (Jonas, 2015a, p.114) As an answer, the “Generic Design Process model” (Figure 1) seeks to accommodate designerly thinking and scientific standards as an RtD process (Jonas, 2007, 2015a, 2015b). It is based on an iterative learning cycle for generating knowledge and reflecting on the outcome, and it is driven by communication; within a team; with stakeholders; with anyone or anything involved. It consists of a macro-process of three phases; Analysis, Projection, and Synthesis (APS/PAS). Each phase instigates a micro-process resembling Kolb’s Learning Cycle containing the stages of: Observation (research), Reflection (analysis), Decision-making (synthesis) and Action (realization).

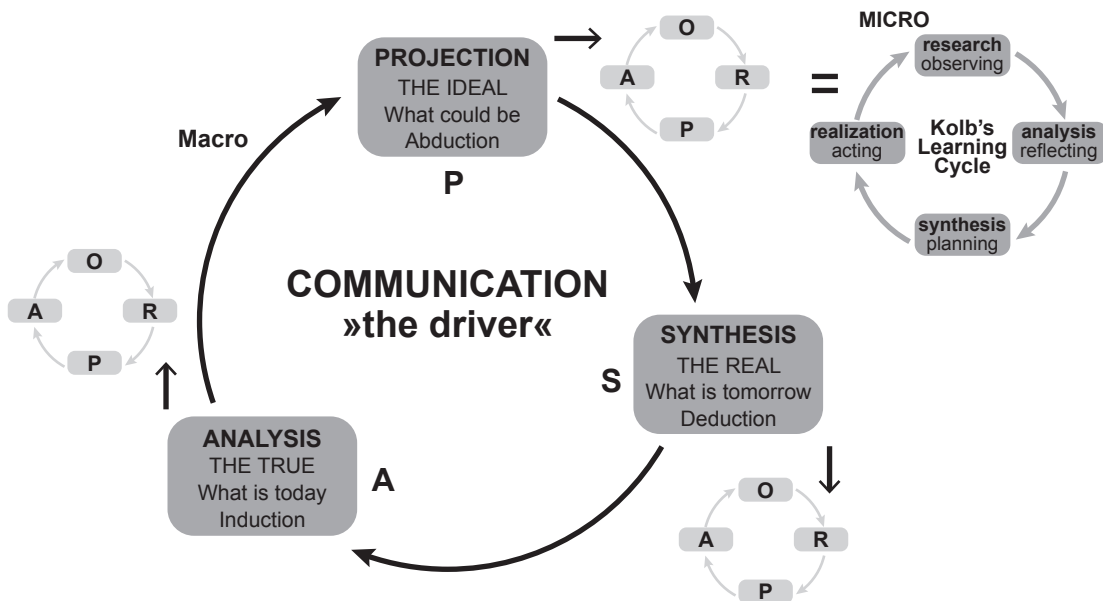

Figure 1. Combining the APS design process (macro) with Kolb’s learning cycle (micro) becomes a generic hypercyclic model of design process i.e. the “Generic Design Process” model (rendering by author, Ollenburg, based on Hugentobler et al., 2004, p.7; Jonas, 2007, p.1375)

The phases in the macro-process generate knowledge from different points of view using<sup>5</sup>:

- (1) Analysis: “The True – What is?” The facts are studied through *induction*; a general rule is derived from a specific observation of the existing: “How is it today?”
- (2) Projection: “The Ideal – What could be?” Beliefs and values are considered through *abduction*; combining observation with intuition to create new insights and ideas: “How could it be?”
- (3) Synthesis: “The Real – What shall be?” Findings of the previous phases are combined to establish the possibility of realization. The deduction results in possible ramifications of the previous knowledge: “How is it tomorrow?” (Jonas & Chow, 2008, pp.2-5)

Furthermore, a “Toolbox” (Figure 2) of key-questions for each phase and stage helps the user to plan and reflect on the needed steps without being overly rigid. The starting phase can be handled flexibly. By beginning with Analysis, it will be more of a problem-driven process, whereas putting the Projection phase first (ideation), the process becomes more solution-driven (Jonas & Chow, 2010, p.5). As part of the mindset of designerly thinking, the process allows trial and error in the recurring learning cycles. Therefore, knowledge for transformation of a given issue is generated in the communication process of a human-centered design approach: “[It] implies a transformation from *professional problem-solving* expertise to *participative projects*, directed by designers, and finally towards *collaborative/collective/communicative action*, possibly facilitated by designers. We face the basic problems of control, due to systemic complexity, and of *prediction*, due to future uncertainty” (Jonas, 2015a, p.127).

		Domains of design inquiry, steps / components of the iterative macro process of designing			
		<b>ANALYSIS “The True” how it is today</b>	<b>PROJECTION “The Ideal” how it could be</b>	<b>SYNTHESIS “The Real” how it is tomorrow</b>	<b>COMMUNICATION “The Driver”</b>
Steps of the iterative micro process of learning / designing	<b>research observing</b>	How to get data on the situation as it IS? → <b>data on what IS</b>	How to get data on future changes? → <b>future-related data</b>	How to get data on the situation as it SHALL BE → <b>problem data</b>	How to establish the process and move it forward? How to enable positive team dynamics? How to find balance between action/ reflection? How to build hot teams? How to enable equal participation? → <b>focused and efficient teamwork</b>
	<b>analysis reflecting</b>	How to make sense of this data? → <b>knowledge of what IS</b>	How to interpret these data? → <b>information about futures</b>	How to evaluate these data? → <b>problem, list of requirements</b>	
	<b>synthesis planning</b>	How to understand the situation as a whole? → <b>worldviews</b>	How to get consistent images of possible futures? → <b>scenarios</b>	How to design solutions of the problem? → <b>design solutions</b>	
	<b>realization acting</b>	How to present the situation as IS? → <b>consent on the situation</b>	How to present the future scenarios? → <b>consent on problems / goals</b>	How to present the solutions? → <b>decisions ab “go / no go”</b>	

Figure 2. The hypercyclic process, linearized into a “Toolbox”: categories of innovation and design methods and tools, questions and results. Source: (Jonas & Chow, 2008, p.3)

## A Discussion: A model of Collaboration

The following proposes a synergy of RtD’s Generic Design Process (GDP) and the concept of alternative futures to enhance participatory futures research by separating scientific research steps and participatory formats: APS/PAS Futures-Design-Process model (Figure 3)

The GDP builds the foundation as a transparent and cohesive structure. The setup of the three phases, including the micro-cycle (Kolb’s Learning Cycle), is meant to encourage designerly knowing and thinking through the stages of being inspired, through observation in combination with reflection, to finally plan and focus on creating tangibles. The GDP is enhanced with the futures studies concept of multiple or alternative futures. Each phase may focus separately on either the analytical-exploratory mode of considering probable and possible futures or the imaginary-normative mode of (un-)desirable or (not-)preferable futures. Such separation in the Analysis and Projection phases aims to give each perspective its own due space. In the end, either way they are compiled in the third phase, Synthesis, as inspiration for plausible futures with the potential of implementation.

The model is based on the premise of multiple perspectives, and in this it is similar to AAL and FAM. By having stakeholders experience, to learn and understand different viewpoints, knowledge is generated to inspire action for transformation. The “Futures-Design-Process model” (F-D-P) works as an iterative discursive participatory research process, using existing exploratory and analytical futures methods (e.g. Delphi, Futures Wheel) as well as established creative and design-

led methods (e.g. visualization, storytelling). The questions used in the GDP Toolbox (Figure 2) can be adapted to become a guide for choosing foresight, design, or creative methods and tools at each step of the process.

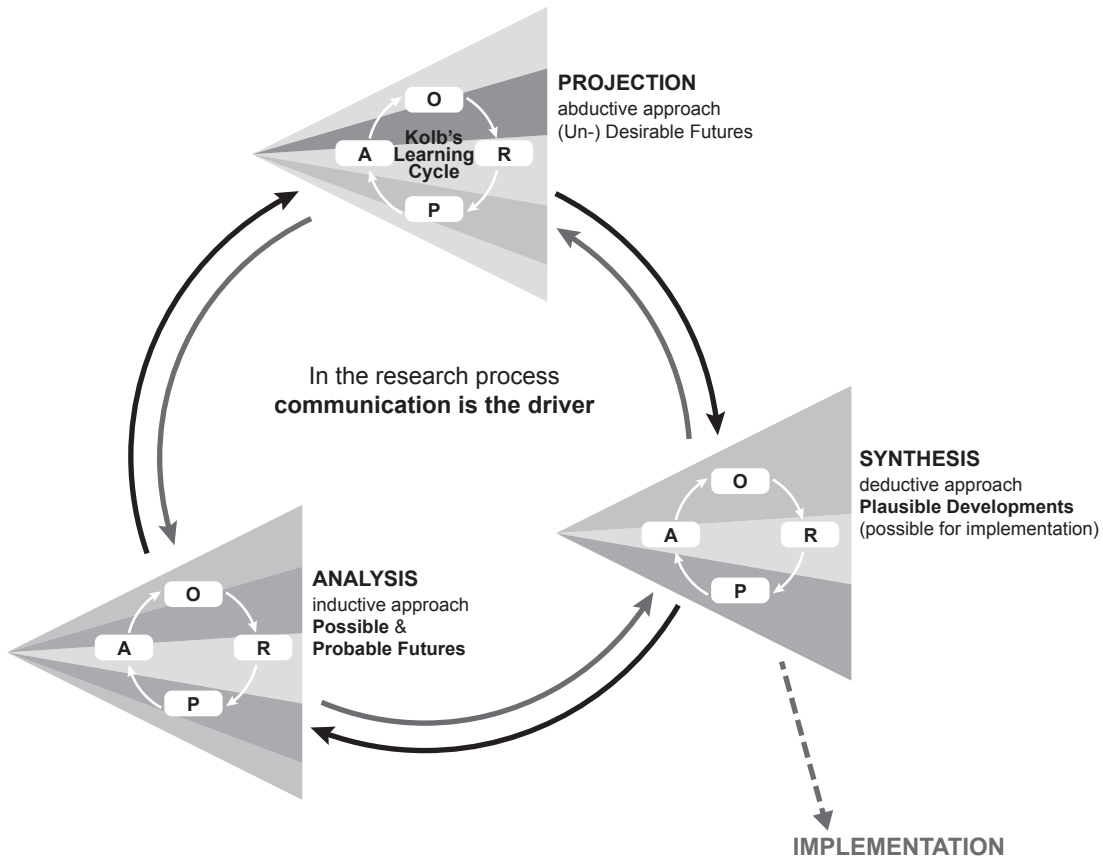

Figure 3. A hypothetical research approach: APS/PAS Futures-Design-Process model (by author: Ollenburg)

Following is an overview of the three phases in the F-D-P. As mentioned above, each includes the stages of Kolb's Learning Cycle:

- **Analysis:** The question is *What can be? What is probable/possible?* The approach is inductive, and includes an in-depth examination of the subject matter – similar to Input and Analysis in Voros' Generic Foresight Framework (2003). Here research will focus on the "given" to find general trajectories, e.g., the observation and analysis of trends and weak signals, as well as interviews or questionnaires among experts or other stakeholders to outline possible and probable future developments.
- **Projection:** The question is *What should be or not be? What is the (un-)desirable?* The approach is abductive, and may include use of creative methods to derive the unexpected. In a participatory workshop format, it first reveals the existing future images of stakeholders, aiming then to inspire and arrive at speculative assumptions, and identify desirable and undesirable future developments.
- **Synthesis:** The question is *What could be? / What are plausible developments?* The approach is deductive, that is, developing ideas uncovered through the previous phases. The information and knowledge gained by the researcher and participating stakeholders flows into their suggestions for potential prototypes. The aim is to let stakeholders experience the future developments in

more vivid forms, for example as an artifact or a narrative. These tangibles may then serve as the basis for the next iteration.

The phases introduced each have a different objective and can be a guide for choosing methods to fulfil the task of the research project, especially in a longer-term assignment. There are parallels here to Ethnographic Experiential Futures (EXF) framework and its phases Map → Multiply → Mediate → Mount → Map (Candy & Kornet, 2019). The F-D-P model is distinguished by the detailed structure of its macro- and micro-cycles. Holding to these steps can support the researcher's goal of reproducibility, and help participants follow the process in each phase. As a participatory framework it encourages facilitators to use methods from design and to visualize ideas, tell stories, generate "artifacts from the future", or similar. On the other hand, methods to support the analytical phase can be more of a scientific and exploratory nature, such as a Delphi survey, trend-scouting and the like.

So far the F-D-P model has been applied in an educational setting. It has served as a framework for students of architecture to experience and work with alternative futures (Ollenburg, 2018), but it would be conceivable to apply to research projects in other settings, for instance, urban planning concerning mobility questions. In such a case, a city council may need to accommodate the inhabitants and businesses of the city and its surrounding area, as well as environmental issues. Applying the F-D-P model, a first step could be to undertake Analysis with experts and stakeholders of present plans to generate probable scenarios for infrastructure development. Then in the Projection phase, in a workshop format, stakeholders could ideate on how their (utopian or dystopian) future city looks, feels and sounds. The results of both phases would need to be evaluated according to their possibility of realization, as well as their preferability among stakeholders. Then there would be a Synthesis phase, carried out by building and experiencing prototypes for their transportation needs.

The key hurdles in such a research design may be less in the defined plan or the various perspectives offered, but in the choice of methods. These need to be made carefully with appropriate objectives in sight. Another challenge known to all participatory formats includes the selection of participants for each phase – who's an expert, and who's a stakeholder?

In this process the researchers explore and analyze data, but also facilitate and organize the discourse. It may need the external expert and stakeholders to generate encompassing knowledge for transformative action. Integrating design methods, by creating tangibles and artifacts for instance, should give participating stakeholders the chance to experience their images of the future. Critically, the framework seeks to adhere to scientific standards and generate data that is a viable foundation for further research.

## Conclusion

Society does not exist as a single entity or coherent system. Shaping the future can thus only take place selectively, individually, or within a particular community. Science and research today do not only explore what exists, but in projects often have the role of finding new pathways for stakeholders who may have very different goals. Even if the task for *researchers* in futures studies is to observe, document and disseminate, many also serve as *facilitators* in transformative processes to shape and design a preferred future. Therefore, such work needs a distinctive research design structure where the roles can be distinguished.

Design and futures studies have become good collaborators, and the F-D-P model advocates a procedural synergy between them, by designing and experiencing futures, accommodating scientific standards, and adding the option of developing projects as transformative action in the context of sustainable development<sup>6</sup>. The balance between macro- and micro-cycles, as well as analytical and

creative steps, are planned to alternate and mutually fertilize each other. The boundaries are fluid, but a delimitation for project designers is offered via the phased structure as well as the Toolbox questions. It also follows suit with participatory futures' objective of generating knowledge for alternative future paths and empowering stakeholders. The transformative action as a final result may or may not be undertaken in collaboration with designers. As in other participatory approaches, the actual realization of one's own ideas is an important motivator for change (Ramos, 2017) and should be kept as one possible objective in the research design within the F-D-P. It supports the idea of empowering stakeholders to become creators of their future.

Designing the future consciously means creating freedom to think and try the impossible. It includes the constant reassessment of results and the responsibility for one's own actions. Despite the wicked problems we face, and the awareness that there is not simply one right solution, a moderate optimism can ignite hope for a better future.

## Correspondence

Stefanie A. Ollenburg  
 Researcher  
 Institut Futur  
 Freie Universität Berlin  
 Germany  
 E-mail: s.ollenburg@fu-berlin.de

## Notes

1. <https://www.ocadu.ca/academics/graduate-studies/strategic-foresight-and-innovation.htm>
2. <https://www.cca.edu/design/design-strategy/curriculum/>
3. <https://www.fh-potsdam.de/studieren/fachbereiche/stadt-bau-kultur/studiengaenge/urbane-zukunft-ma/>
4. The design method of Cultural Probes would be an example of such a tool for communication
5. "The True, The Ideal, The Real" derived from. Nelson and Stolterman, "The Design Way", cited in Hugentobler et al., 2004, pp. 6-7.
6. Transformative research understood as transdisciplinary and participatory research in the context of sustainable development could embrace this type of model as well.

## References

- Bishop, P. C., & Hines, A. (2013). Framework foresight: Exploring futures the Houston way. *Futures*, 51, 31-49. doi:10.1016/j.futures.2013.05.002
- Candy, S. (2010). *The futures of everyday life: Politics and the design of experiential scenarios* (PhD Dissertation). Department of Political Science, University of Hawaii at Manoa. doi:10.13140/RG.2.1.1840.0248
- Candy, S., & Dunagan, J. (2017). Designing an experiential scenario: The people who vanished. *Futures*, 86, 136-153. doi:10.1016/j.futures.2016.05.006
- Candy, S., & Kornet, K. (2019). Turning foresight inside out: An introduction to ethnographic experiential futures. *Journal of Futures Studies*, 23(3), 3-22. doi:10.6531/JFS.201903\_23(3).0001
- Cross, N. (2006). *Designerly ways of knowing*. London: Springer [electronic version].
- Dator, J. (2009). Alternative futures at the Manoa School. *Journal of Futures Studies*, 14(2), 1-18. Retrieved from <http://www.jfs.tku.edu.tw/14-2/A01>

- Findeli, A. (2010). Searching for design research questions: Some conceptual clarifications. In R. Chow, W. Jonas, & G. Joose. *Questions, hypotheses & conjectures* (pp. 286-303). New York: iUniverse.
- Gidley, J. M. (2017). *The future: A very short introduction*. Oxford: Oxford University Press.
- Grunwald, A. (2014). Modes of orientation provided by futures studies: Making sense of diversity and divergence. *European Journal of Futures Research*, 2(1). doi:10.1007/s40309-013-0030-5
- Hines, A., & Zindato, D. (2016). Designing foresight and foresighting design, *World Futures Review*, 8(4), 180-192. doi: 10.1177/1946756716672477
- Hugentobler, H. K., Jonas, W., & Rahe, D. (2004). Designing a methods platform for design and design research. Paper presented at *Futureground, DRS*. Melbourne, Australia. Retrieved from [http://8149.website.snafu.de/wordpress/wp-content/uploads/2011/08/2004\\_Melbourne.pdf](http://8149.website.snafu.de/wordpress/wp-content/uploads/2011/08/2004_Melbourne.pdf)
- Inayatullah, S. (2008). Six pillars: Futures thinking for transforming. *Foresight*, 10(1), 4-21. doi:10.1108/14636680810855991
- Jonas, W. (1997). N-th order design? Systemic concepts for research in advanced methodology. Submitted to *Design Issues* special issue on design research (unpublished).
- Jonas, W. (2007). Research through DESIGN through research; A cybernetic model of designing design foundations. *Kybernetes*, 36(9/10), 1362-1380. doi:10.1108/03684920710827355
- Jonas, W., & Chow, R. (2008). Beyond dualisms in methodology: An integrative design research medium (MAPS) and some reflections. Paper presented at *DRS Conference Undisciplined!* Sheffield, UK. Retrieved from [http://8149.website.snafu.de/wordpress/wp-content/uploads/2011/06/2008\\_Beyond-dualisms.pdf](http://8149.website.snafu.de/wordpress/wp-content/uploads/2011/06/2008_Beyond-dualisms.pdf)
- Jonas, W., & Chow, R. (2010). Far beyond dualisms in methodology: An integrative design research medium (MAPS). Paper presented at *DRS Conference Design & Complexity*. Montréal, Canada. <http://www.drs2010.umontreal.ca/data/PDF/057.pdf>
- Jonas, W. (2015a). Social transformation design as research through design (RtD): Some historical, theoretical and methodological remarks. In W. Jonas, S. Zerwas, & K. von Anshelms (Eds.) *Transformation design* (pp.114-133). Basel: Birkhäuser.
- Jonas, W. (2015b). Research through design is more than just a new form of disseminating design outcomes. *Constructivist Foundations*, 11(1), 32-36. Retrieved from <https://constructivist.info/articles/11/1/032.jonas.pdf>
- Kelliher, A., & Byrne, D. (2015). Design futures in action: Documenting experiential futures for participatory audiences. *Futures*, 70, 36-47. doi:10.1016/j.futures.2014.12.004
- Kreibich, R., Oertel, B., & Wölk, M. (2011). Futures studies and future-oriented technology analysis principles, methodology and research questions. *HIIG Discussion Paper Series No. 2012-05*. doi:10.2139/ssrn.2094215
- Krippendorff, K. (2006). *The semantic turn*. Boca Raton, FL: Taylor & Francis.
- Kuhnt, B., & Müllert, N. R. (2006). *Moderationsfibel Zukunftswerkstätten: Verstehen, Anleiten, Einsetzen: das Praxisbuch zur Sozialen Problemlösungsmethode Zukunftswerkstatt* (3rd ed.). Verein zur Förderung der sozialpolitischen Arbeit.
- Ollenburg, S. (2018). Beyond futures: Designing futures by educating future designers. *World Futures Review*, 10(4), 279-293. doi:10.1177/1946756718790758
- Owen, C. (2007). Design thinking: Notes on its nature and use. *Design Research Quarterly*, 2(1), 16-27.
- Popp, R. (2013). Participatory futures research. Research or practice consulting? *European Journal of Futures Research*, 1(1). doi:10.1007/s40309-013-0016-3
- Ramos, J. M. (2013). Forging the synergy between anticipation and innovation: The futures action model. *Journal of Futures Studies*, 18(1), 85-106. Retrieved from <http://www.jfs.tku.edu.tw/18-1/A05.pdf>

- Ramos, J. M. (2017). Linking foresight and action: Toward a futures action research. In L. L. Rowell, C.D. Bruce, J. M. Shosh, & M. M. Riel (Eds.). *The Palgrave international handbook of action research* (pp. 823-842). New York: Palgrave Macmillan.
- Seefried, E. (2014). Steering the future. The emergence of “Western” futures research and its production of expertise, 1950s to early 1970s. *European Journal of Futures Research*, 2(1). doi.org/10.1007/s40309-013-0029-y
- Voros, J. (2003). A generic foresight process framework. *Foresight*, 5(3), 10-21.



# Imagining 2060: A Cross-Cultural Comparison of University Students' Perspectives

Jeanne Hoffman  
Tamkang University  
Taiwan  
University of the Sunshine Coast  
Australia

---

## Abstract

*This study is an investigation into the preferred images of the environment in 2060 held by a cross-cultural cohort of undergraduate students at Tamkang University, Taiwan. The findings indicate that students believe they have a low level of agency to bring about their desired futures, although they are confident in the power of technology to achieve them. The study uses a combination of survey, imaging through drawing, and causal layered analysis (CLA) to deconstruct the current dominant options around climate change and the environment, and reconstruct future anticipations.*

**Keywords:** 2060, Causal Layered Analysis, Climate Change, Cross-Cultural Research, Curriculum Design, Images of the Future, Surveys.

---

## Introduction

The 2018 UN Intergovernmental Panel on Climate Change (IPCC) Special Report warned that only a dozen years' window remains for humanity to act to keep global warming to a maximum of 1.5°C and avoid the catastrophe of extreme heat, drought, floods and poverty (IPCC, 2018). In my years of teaching futures studies at Tamkang University, climate change and its impact on the living environment has been an important area of concern for many of my students, and it is with this circumstantial knowledge that a deeper inquiry into students' environmental attitudes is needed. College students are underrepresented on research dealing with environmental attitudes (Wilcox, 2014). While many students face the future with hope, goals, and success, others associate the concept of the future with fear and uncertainty (Zaleski, 2005). Future anxiety and 'climate grief' have been seen to exact an emotional toll creating depression and resignation about the future (Scher, 2018).

According to a 2018 Yale survey (Leiserowitz et al., 2018) anxiety is rising in the US over the climate. Sixty-two percent of people surveyed said they were at least 'somewhat' worried about the climate. Those who described themselves as 'very' worried accounted for 21 percent, about twice the rate found in a similar study

in 2015. Worryingly, the survey found that only 6 percent believed that humans can and will reduce global warming (Leiserowitz et al., 2018). In Asia, Ono (2005) surveyed youth in Japan from 1998-1999 and again in 2000, where only 34 percent of youth professed optimism about the future, and 64 percent believed that the environment would worsen within 20 years. Di Giusto, Lavallee and Yu (2018) investigated climate change knowledge, concern and behavioral change among students at nine universities in Taiwan. They found that Taiwanese students had a high level of knowledge and concern about climate change, but that this concern has not translated into action, perhaps in response to the conflict between economic growth and the environment which requires more policy leadership.

While Greta Thunberg, the 16-year-old Swedish climate activist has called for change to our economic and political systems (Rigitano, 2018), many of my university students, although sympathetic to Ms. Thunberg's concern, have expressed the belief that they don't have the agency or the understanding of what a new system would look like. This lack of a preferred image of the future leads to a kind of ambivalence toward 'fixing' the problem of climate change. The work of Kaboli and Tapio (2017) argues that "the images of the future of the contemporary young adults are influenced by the characteristics of the current era...the social reality and the images of the future reinforce each other through a feedback loop" (p. 33). One of the pervasive issues affecting any attempt to design and pursue preferred futures collectively, which also affects the teaching of futures thinking at the scale of the classroom, is that people are bound by and biased toward present circumstances; a fundamental problem when engaging in issues related to environmental sustainability (Saijo, 2015; Kamijo, Komiya, Mifune, & Saijo, 2016).

My own style of teaching is to engage students in thinking about long-term futures and foresight strategies through active learning and gaming. This allows students to internalize knowledge, communicate and share ideas, and broaden participation to create new futures knowledge and build agency (Raford, 2012; Chen & Hoffman, 2017). In the first week of class I immediately engage the students to think about their own future using a game inspired by Wheelwright (2010) from his book *It's Your Future... Make it a Good One!* The students are given some foundational concepts from futures studies and are asked to think about their own lives and the actions they will take today to shape the future they desire in 20 years' time (Chen & Hoffman, 2017). They are prompted to think about images of the future, and how those images impact the way we see and act in the present. To start the conversation, a quote from Polak is used that has been found to resonate quite strongly (Chen & Hoffman, 2017):

*The rise and fall of images of the future precedes or accompanies the rise and fall of cultures. As long as a society's image is positive and flourishing, the flower of culture is in full bloom. Once the image of the future begins to decay and lose its vitality, however, the culture does not long survive. (Polak, 1973, p. 19).*

In the last three years, nearly 90% of students submit a conventional, present-based image of their future in 20 years' time: go to school, find a good job, get married, have children or pets.

In the second week of class each semester, students' attitudes are further examined by playing 'The Polak Game', as described by Hayward and Candy (2017). In this activity they arrange themselves by degrees on a vertical axis according to how optimistic or pessimistic they are about their future and the state of the world. On the horizontal axis they are then asked to show how much agency they have to influence the future they wish to see. While the activity is limited in that it represents a pair of relatively simple spectrums, subsequent discussion of where students locate themselves and why provides the opportunity to surface individual concerns about the future and how much power they believe they have to influence what they often see as an inevitable path. In three years of doing this activity, two major areas of concern have generally been revealed: artificial

intelligence and climate change. As well, usually about half the students believe they have agency over their own future, while the other half think they cannot influence their own futures, as a product of societal pressures, nor can they influence society itself. Usually only one or two believe that their actions can change the course of their future as well as have an impact on society.

In both games, students often seem to follow the same pattern observed by Toffler in 1974:

*No matter how turbulent a world they pictured, no matter how many new technologies might appear or what political revolutions might take place, the way of life foreseen for themselves as individuals seldom differed from the way of life possible in the present and actually lived by many today.*

And Galtung in 1976:

*...the future seems somehow to be synonymous with a technological future...But it seems more probable that they have only been trained to think technologically and have no other types of thoughts as a response to the stimulus 'future'; or at least have not been trained to express any other thoughts.*

University students represent an important cohort of the population, including leaders of tomorrow; individuals likely to play a key role in decision-making regarding climate change mitigation, adaptation, and policy. They are also the next generation of citizens (voters) and consumers. This is the first study to ask cross-ethno cultural groups and a variety of majors and degrees studying in Taiwan about their beliefs concerning climate change through the lens of a futures framework, causal layered analysis. Students come from 24 different countries broadly categorized by their origin, location, and comparable geographical assets: Taiwan, Asia (Japan, Hong Kong, Macau, China, Indonesia, Malaysia), Africa (Eswatini, Malawi, Burkina Faso), Caribbean and South & Central America (Mexico, El Salvador, Nicaragua, Peru and Paraguay, Haiti and Saint Lucia), Europe (Italy and Russia), the United States and Pacific Islands (Solomon Islands, Marshall Islands, Kiribati and Nauru). It is assumed that students from low-lying Pacific Islands and Caribbean countries would consider themselves more vulnerable to the near term future manifestations of climate change because of their proximity to and reliance on natural ecosystems (Scott-Parker & Kumar, 2018).

## **Research Questions and Methodology**

The aim of the study was to examine the perceptions of international undergraduate university students in Taiwan towards climate change and the environment. It is well known that images of the future precede action, and a number of studies have sought to gauge the similarities and differences between such images (Chen, 2016; Ono, 2005; Hicks, 1996). In a world of unknowns, especially for young students, it is important to understand their perceptions of the future as well as their perceived ability to shape it (Polak, 1973).

The exploratory study used a survey format administered in the second semester of 2019 across three classes called "Political Futures", an English-language course attracting a cross-section of Taiwanese domestic and international students. A total of 77 surveys were administered with 11 questions, a mix of multiple choice and short answer, and the students were given one week to complete the task outside of the classroom. International students are particularly attracted to the class because it is taught in English, and this adds to the variety of students. Majors included English, Spanish, German, Chinese Literature, Civil Engineering, International Business, Business Administration, Finance, Diplomacy and International Relations, Computer Science. There were forty-five female and thirty-two male participants.

This survey was slightly different in that the students were also asked to draw a picture of what their preferred environmental future in 2060 would look like. The time horizon of 2060 was chosen to give the students enough runway to break from business-as-usual climate change visions, to something that could be remarkable and transformative. While the UN IPCC provides a 12-year timeframe in which to make the necessary changes, the intended outcomes themselves would take longer to emerge. Although this study does not specifically address postmaterialist values as described by Ronald Inglehart (1971) — when material affluence increases, quality of life issues tend to replace economic and physical security — the findings do point toward increasing postmaterialism and greater concern for the environment, albeit with the help of technology.

Asking the students to draw a preferred vision for 2060 is a technique to investigate their conceptions of images of the future. Drawings are widely assumed to represent thinking about, and interaction between, a person's inner and outer worlds (Kress & van Leeuwen, 1996; Liu & Lin, 2018). The thinking was further developed through causal layered analysis (CLA) to expand the range and richness of the envisioned scenarios (Inayatullah, 1998). The combination of visioning and CLA allows further insight into the students' fears and desires, and the opportunity to learn how much power they believe they have to influence climate change. The four layers of CLA include, first, the *litany* — the visible quantitative trends and problems depicted in the media often on the aspects of the issue which simulate the feelings of helplessness and apathy (Inayatullah, 1998; Riedy, 2008). The second layer is concerned with the *system* of social problems and those who would 'fix' or create those problems; the role of the state and government and other actors is explored here. The third is the *worldview* that supports and legitimizes the issue. The fourth level is the *myths and metaphors* — the "deep stories, the collective archetypes, the unconscious dimensions of the problem" (Inayatullah, 1998, p.820).

## Results and Discussion

The survey questions were also categorized using CLA, a framework for exploring images of the future and their underlying meanings on different levels. The first four questions discussed below probe the student's understandings of the current state of the environment and their preferred images of 2060.

### Research Questions 1 and 2: "How concerned are students about the current (2019) and future (2060) state of the environment and climate change?"

While the majority of students were either 'extremely' or 'moderately' concerned with the present and future state of the environment, what's interesting is that they were *less* concerned about the future than about the current state. Not one student across all the classes was completely unconcerned by the present state of the environment, and only one was unconcerned about its state in 2060. This counterintuitive result appears to be largely explained by students' confidence that progress in technology and science would be a major factor in 'solving' climate change. This can be seen in their response in the systemic solutions to climate change analyzed further in the CLA section.

Eight of twelve students from the Pacific Islands were extremely concerned about the current state. One from Tuvalu said, "It will be really different from today, because from what I know there's lots of things that are changing, so maybe by 2060 I will migrate to another country because of climate change". Some appeared less concerned about the future state than we might have expected, and again, confidence in technology was a major reason. Among those who declared themselves extremely concerned about the future state, there was the belief that "the world started a little too late". A common element across all Pacific Island students' drawings was a desire to live in harmony with nature with the assistance of technology, or to go back to nature. Turning to other

low-lying countries vulnerable to rising seas, the student from Saint Lucia was more concerned about the sun's rays and proposed living under a dome. The student from Haiti was concerned about preserving nature through community action, for example, protesting against cutting down trees.

Of the four students from Africa, only the two from Malawi were 'extremely' concerned about the current state of the environment. They differed on the future state, with one being only 'slightly' concerned and believing that technology will play an important role in reducing pollution by 2060.

Of the 22 students from the rest of Asia, only five were extremely concerned about the present state of the environment. One said "global warming remains unsolved and it gets worse with each passing year. Our actions and reluctance to radically change our lifestyle for the better of the environment will drastically impact our future". When thinking about the future state of the environment the remainder were moderately concerned (n=9), somewhat concerned (n=6) and slightly concerned (n=2). Advancement in technologies was given as the reason.

Of the seven students from Central and South America and the Caribbean, four were extremely concerned about the present but only two were similarly concerned about the future. One remarked, "even though we have made progress with fighting climate change through environmental awareness, international summits and taking real action to lower our emissions, there is still a lot to be done. Only if there is real compromise from powerful countries such as the US and China will the world have real chance of transforming our environment".

Of students from the USA and Europe, just one was extremely concerned about the current state of the environment, and none about its future. The US student remarked, "The future is going to be green and people's desire to help the environment is on the rise." This specific recognition of global human agency was unique among responses, with others reflecting a faith in the power of technology to "promote harmony between man and nature".

Taiwanese students were somewhat outliers compared to the rest, in relation to these two questions. They expressed more concern with the future state of the environment than with its present by a factor of one. For the present, only three said they were 'extremely' concerned. Nine were 'moderately' concerned, fourteen 'somewhat' and three 'slightly'. As for the future state of the environment, four were 'extremely' concerned, nine 'moderately', seven 'somewhat', seven 'slightly' and one 'not at all'. Again technology was reported as the key reason for students' belief that the future would be better than the present, but one extremely concerned about the future cited "greed, power, money, too little time and always something more desirable to an individual, leading them to opt out from choosing what is best for society".

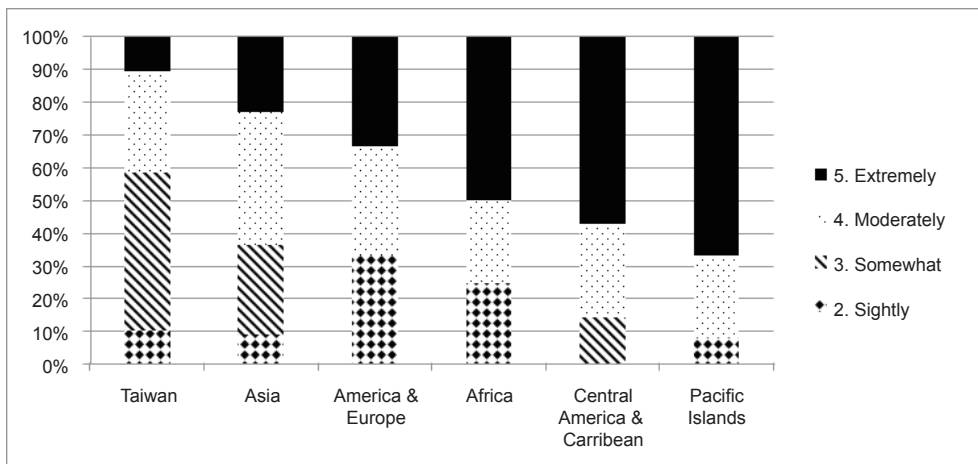

Figure 1. Cross-cultural comparison of level of concern for the current (2019) state of the environment

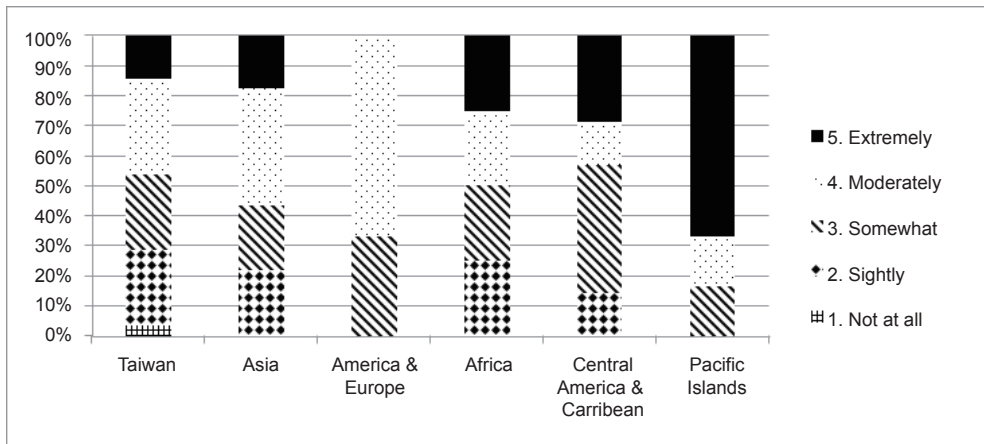

Figure 2. Cross-cultural comparison of level of concern for the future (2060) state of the environment

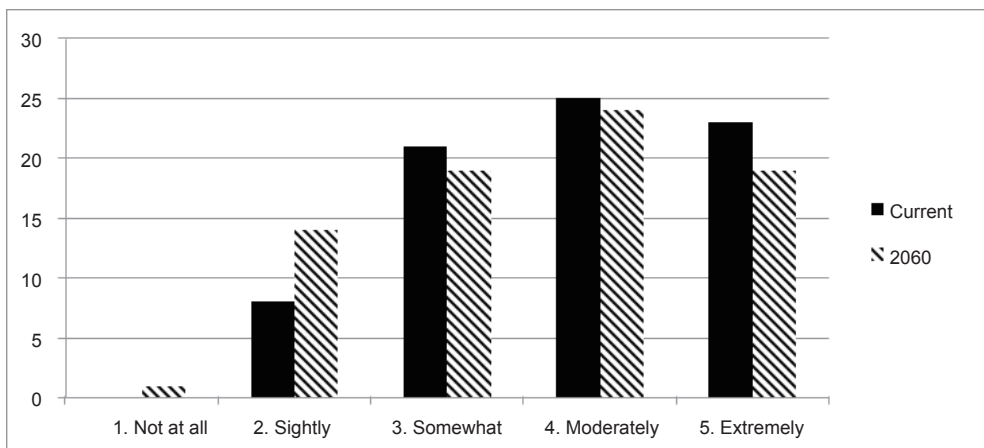

Figure 3. Comparison of concern levels for current (2019) and future (2060) environmental states

Part of this discrepancy is accounted for in the answers to question 3 (Figure 2): “How likely do you think your preferred future will happen in 2060?” About half the students believed their preferred future was either ‘likely’ or ‘extremely likely’ to happen, as opposed to ‘extremely unlikely’, ‘unlikely’, or ‘neutral’. The cited reasons were techno-scientific in character, including that “AI will be extremely well developed at that time”, “more scientific discoveries and technologies will happen in the future” and “with advanced technology everything can be built to an advanced level”.

Among those more pessimistic about the likelihood of their preferred future eventuating came from the Pacific Islands: “Kiribati is one of the most vulnerable countries to climate change. Based on what I have seen and learned, my preferred future cannot happen unless we take action right away”; “With technology advancing everyday, homes surrounded by forest or by the ocean won’t be an option. My country (Marshall Islands) is one of many that face the threat of sea level rising” and “advanced countries focus their research on electronic machines”.

### **Research Question 3: “What are the images of preferred futures for 2060?”**

Analysis of the images showed found that they fell into five broad categories: Altered City; Technology Improvements; Environmental Quality; Relocation; and a few that did not neatly fit among these other four (see Table 1).

The majority of students (49%; n=38) envisioned their preferred future as an altered city landscape that included solar panels, electric cars, wind farms and other uses of green technology. Although this category also incorporated many technology improvements and environmental quality elements alike, there were enough images featuring technological improvements *outside* the context of the city that this was deemed a separate category of future image.

The students frequently drew energy efficient buildings with rooftop solar panels, and abundant trees and parks, even in a technologically-altered landscape. Flying cars and high-speed rail, considered to be environmentally friendly, were common features. One student was very specific in articulating that within the dome, there would be room for wild animals, rivers, mountains and lakes, while outside the dome would be skyscraper workspaces.

Four students envisioned a domed city as part of their preferred 2060 state, to protect humans from ultraviolet rays.

The second highest number of responses fell under the category of ‘environmental quality’ (25%; n=20). They include natural landscape such as trees, lakes, streams, fish, mountains, etc.

Three students (two female, one male) believed that relocation to Mars was the only option for humanity. This could be partly due to high awareness within this cohort about Elon Musk and his desire to colonize Mars (Solon, 2018), while also suggesting a fear of worsening environmental conditions and lack of hope for a solution.

Three students also indicated that only simplifying life and returning ‘back to nature’ could save humanity and the planet; ideas representing a dramatic change to how the current world economy works, and also perhaps a rejection of technology as planetary savior. There were two students who could not see anything but disaster.

A point of difference was among the students from the Pacific Islands: Solomon Islands, Kiribati, Nauru and Marshall Islands who saw their preferred future in terms of physically losing their island homes, and as more than one student said, “don’t need to apply to be a climate refugee”.

The categorization of these images is shown in Table 1.

Table 1. *Students' preferred environmental futures*

Category	Topic
Altered City	<ul style="list-style-type: none"> <li>• Electric cars/driverless vehicles/no carbon cars</li> <li>• Flying cars</li> <li>• Solar and windmills in the city</li> <li>• Trees and plants everywhere</li> <li>• Lower buildings / no more high rise apartments</li> <li>• Dome city</li> <li>• Recycling centers in the city</li> </ul>
Technology Improvements	<ul style="list-style-type: none"> <li>• Solar panel farms</li> <li>• Robots everywhere doing work</li> <li>• Wind power</li> <li>• Technology helping nature</li> </ul>
Environmental Quality	<ul style="list-style-type: none"> <li>• Clean air and water</li> <li>• More trees</li> <li>• Forests, mountains and lakes</li> <li>• Blue skies</li> <li>• Abundant food resources</li> </ul>
Relocation	<ul style="list-style-type: none"> <li>• Mars</li> <li>• Space settlement / Stanford Torus</li> <li>• Floating island</li> </ul>
Others	<ul style="list-style-type: none"> <li>• Back to nature</li> <li>• Disaster</li> <li>• Humans become altered to survive pollution</li> </ul>

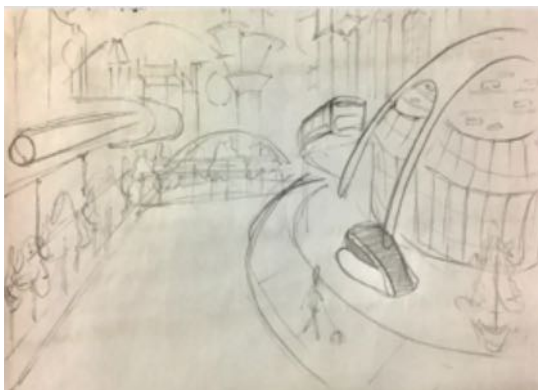

A



B

Image 1. Altered City

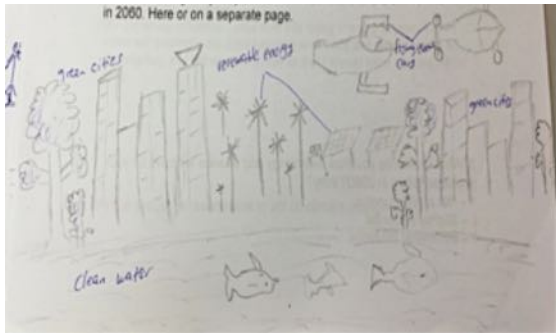

A

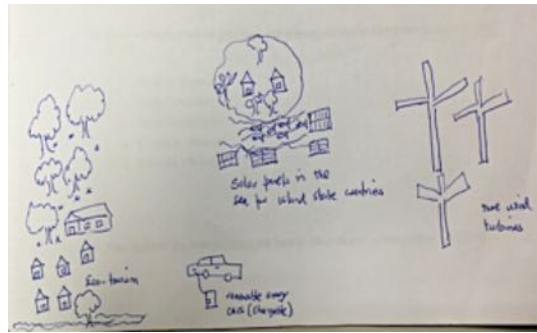

B

Image 2. Technology Improvements



A



B

Image 3. Environmental Quality

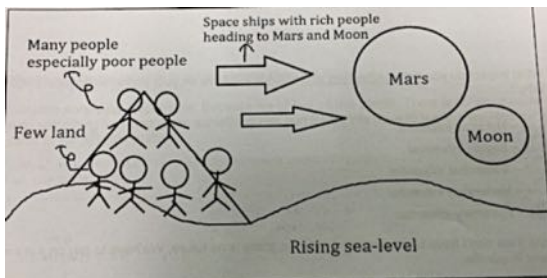

A

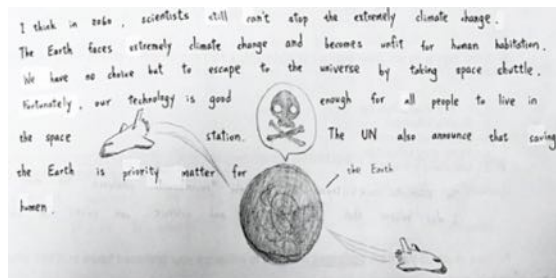

B

Image 4. Relocation

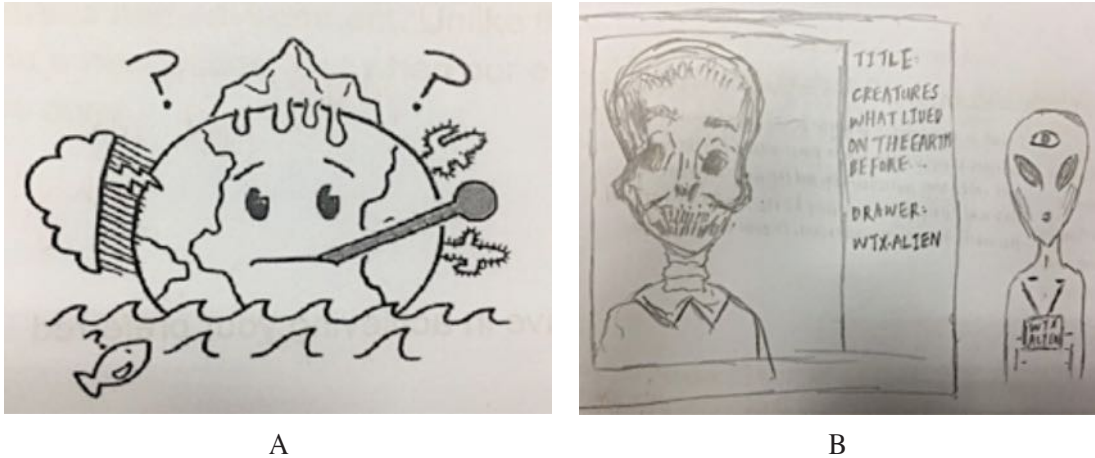

Image 5. Others

#### Research Question 4: “How likely do students perceive their preferred version of 2060 to be?”

More than half of the students ( $n=44$ ) believed their preferred environmental futures were ‘extremely likely’ or ‘likely’ to happen. The primary reasons given were techno-science related. Notably, many of those who answered in this hopeful mode cited reasons for that hope relating more to their own personal future than to the collective register of climate change. The students with ‘unlikely’ or ‘neutral’ responses ( $n=33$ ) described concerns that society was not sufficiently determined to change behaviors, or that technology would not be advanced enough, or might itself create new problems.

An example of the students’ faith in technology as a significant factor in achieving their preferred futures, one student said, “My preferred future is full of high tech devices. And the current technology is advancing, so I think my future is quite possible”. (Image 2A) Another student who believed their preferred future was extremely likely said, “I do believe in humans that they are still good and can build a better future for our survival”. (Image 3B)

‘Neutral’ respondents appeared to feel a lack of agency. One said, “What I want is to have technologies to monitor and help the future. I think it will happen – if humans haven’t destroyed the environment first”. Another said, “...because the variation of the future is uncountable, there are too many possibilities about the future, so I could not say that it is likely or unlikely, just neutral and go with the flow”.

Those who judged their preferred 2060 ‘unlikely’ were consistent in their belief that it is too late to halt climate change, and that it’s more likely humans will adapt rather than take ‘extreme’ action in the present. A female from Malaysia said, “...more scientific discoveries and technologies will happen so it will be more convenient for us, but we will somehow lose interaction with people around us”.

Another female student from Malaysia, whose image of the future showed improved environmental quality with open space and trees, considered it ‘extremely unlikely’, “because nowadays people look forward to AI, so they will build more factories”.

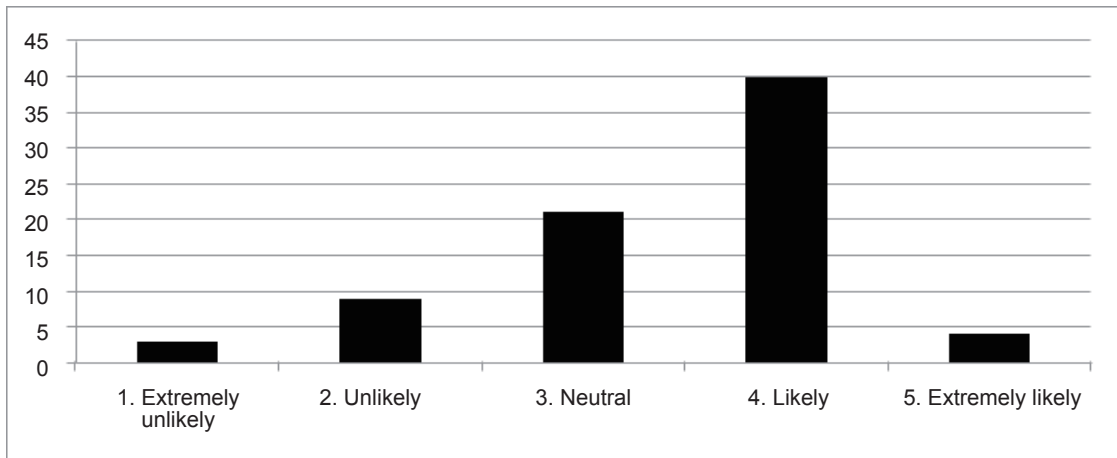

Figure 4. Students' estimated likelihood of their own preferred futures (2060)

## Causal Layered Analysis

In order to better understand the relationship between students' preferred images of the environment in 2060 and their levels of social learning and agency, questions were asked to unpack their hidden assumptions (Bussey, 2014). Questions 1, 2 (state current and future environmental concern levels), 3 (draw preferred image) and 4 (likelihood) gauged concerns, provided a snapshot of the preferred future, and measured their perceptions of likelihood, the explanations of which helped illuminate their perceived level of agency in relation to achieving it. Questions 5 through 11 were sequenced around the progressive unpacking of CLA's layers, moving from (a) considering the litany of conventional perceptions of reality, the most visible and obvious elements, as given by the media and generally accepted within the dominant viewpoint, to (b) identifying the structural role of various actors that the respondents believe to be responsible for creating and acting to 'fix' climate change, to (c) questioning their own worldviews as well as those of others they believe are responsible to act, and finally to (d) exploring the myths and metaphors that constitute our deepest emotional stories, which validate the world we create and the circumstances by which we live (Inayatullah, 1998).

Students' litany-level answers show that they are aware of climate change and believe it is real, but a number of answers also suggest that some are confused by what they hear in the media and from politicians. Technology and science was perceived to be a far greater influence on achieving students' preferred futures than politicians (Figure 5). It was commonly believed that future technology will be better, and that this is the key to addressing climate change, providing improved quality of life and convenience, and bringing us a brighter future. Only two students indicated that technology and science would not be influential in this way (but unfortunately one response was unintelligible, and the other did not explain why). Overwhelmingly, respondents were suspicious of politicians' ability to act on climate change to achieve their preferred futures. US President Donald Trump and his denial of climate change featured in four responses. Many of the students come from countries with high levels of corruption and saw climate change-denying politicians, and "right wing social media [that] might support this...to ignore the fact", as embodying a form of moral corruption.

There does not appear to be a strong correlation between the future image that students desired and their self-assessed ability to influence it becoming a reality. Some misunderstood the question and addressed their own 'life' image of the future only, rather than that of the environment more

broadly. Half of the students who judged that their own actions would be ‘extremely’ influential said so because they would work hard to achieve their goals.

The majority were somewhat apathetic about their ability to influence the future. One said, “I don’t think anything will happen or change because of me. I still have so much to learn”. Another echoed this by saying, “I don’t think my actions will influence the future much. Because I don’t really understand the technology thing”. One student who evaluated their own actions as only ‘slightly’ influential admitted, “Being honest, most of the times I do not care too much about the environment and the consequences from my actions, but I am in the process of changing to help produce the desired future. In summer I go to clean the streets and I recently started to recycle, but changing my bad habits is somewhat hard”. These conflicting comments align with research suggesting that in this rapidly changing world — Bauman’s (2012) ‘liquid modernity’ — “some young adults are floating between what they desire and their fears of the hazardous, more than ever uncertain future” (Kaboli & Tapio, 2017, p.41).

This dissonance is further elaborated by the question of who students believed should be responsible for acting on climate change. A full 95 percent answered ‘everyone’ or ‘everybody’ or ‘all the people on earth’. Polak (1973) argued that the image of the future has two main dimensions: *essence* and *influence*; essence being the unchangeable course of events, and influence referring to the power that individuals have over their own destiny. The students seem to believe that although they had limited control over achieving their desired future, ‘everybody’ is needed to make change. They also appeared to believe that technology and science would provide the ‘essence’ of change to achieve their desired image.

The metaphors used to express current environmental reality, the fourth CLA layer, show great concern for the current health of the planet. All these metaphors also reflected the need for urgent action on climate change: “moment of change”, “now or never”, “big hole everyone tries to mend”, “elephant in the room”, “a train that is halfway to hell”. It was encouraging that the metaphors for 2060 reflected not only technology’s role, but a desire to live in ways more reflective of Gaia, the ancestral mother of all life: “peaceful, cool and clean”, “Genesis” (of new technology, energy policy to save the earth), “before the industrial revolution”, “sweet ending but rough trip”, “a great sunflower field”. Sunflowers stand tall and find the sunlight; likewise the earth and human beings should learn from the spirit of sunflowers.

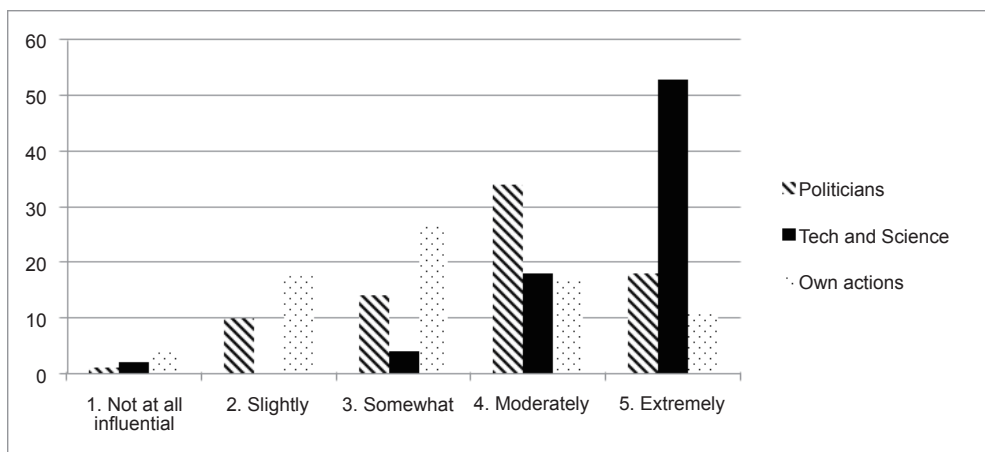

Figure 5. Comparison of perceived levels of influence in achieving preferred future: Politicians vs Technology and Science vs Own actions

Table 2. *Causal Layered Analysis*

Layer	Current	2060
Litany	Rich are getting richer. We are polluting the earth and humans causing global warming, natural disasters more common. Politicians are lying to us. Too far out. Biggest crisis for mankind.	Hard to imagine. Future oriented policies – for the future generations. We have done it!
System	Technology can bring destruction or can help us. Fake news is popular. People are unconnected. Politicians don't care. They control the media, internet. Try to control the elections.	Our leaders have a desire for postmaterialist values. We live better and healthier lives through the work of technology and science. Internet, social media help us connect with politicians and make people feel empowered.
Worldview	I don't feel empowered to help. My actions are too small. We need to work together.	I work in a technology company that will focus on developing innovations to save the earth. Teach young children to respect the earth. Everyone, everybody, all the people work together.
Metaphor	The earth is gasping. Like wearing headphones and people screaming "watch out for that hole in front of you!" Flying on an old but comfortable airplane. Our activities are loosening the rivets that hold the plane together, but many on the plane don't know about it.	Heaven on earth. On top of a mountain with the beauty of nature and sun. Hearing birds chirp and flying above and everything is fine. Passengers fix the plane until it is a new airplane.

## Conclusion

This study examined the perceptions toward climate change and the environment held by international and domestic undergraduates, with various cultural backgrounds, studying in Taiwan. The results were calculated through a Likert-scale survey instrument, through individuals drawing their vision of a preferred future, and through use of causal layered analysis (CLA) for making sense of both the depth and breadth of answers given.

Technological solutions to climate change appear to give the student participants in this research a kind of preferred certainty. Rather than relying on politicians, whose influence is eroding and who provide little if any reassurance, students seem to look to technology as creating the conditions to solve environmental problems; solar panel farms in cities, driverless electric vehicles, relocating to Mars. Answers given throughout the CLA reflect Bauman's observation that:

*Living under liquid modern conditions can be compared to walking in a minefield: everyone knows an explosion might happen at any moment and in any place, but no one knows when the moment will come and where the place will be (Bauman, 2012, p. xiv).*

The conclusion from the analysis of this survey agrees with Liu and Lin (2018), that students who hold a positive view about techno-science believe their preferred environmental futures will happen, and the corollary, that they are also less concerned about the environment.

The perceived lack of agency and sense of powerlessness in the face of climate change was surprising, although environmental awareness in Taiwan is high. Students whose lives are more apt to be immediately impacted by climate change — from the Pacific Islands of Tuvalu, Nauru, Marshall Islands and the Solomon Islands — did not appear to have any great sense of agency.

While respondents' own drawings of their preferred futures served very well as one of the points of departure for this study, it remains to be explored in future research how the use of other forms of media, arts, and design (Van Leemput, 2019) might add dimensionality and power to students' images of the future, using an experiential futures-based curriculum design (Dunagan et al., 2019) or ethnographic experiential futures intervention (Candy & Kornet, 2019).

Meanwhile, what the CLA analysis does find is that universally, students are hopeful, either in relation to their own actions, or in relation to the action of technology, about solving climate change. Postmaterialist values are strong. What is needed is for students to be encouraged toward positive-agency oriented roles, where they believe they can act towards achieving their preferred futures.

## Correspondence

Jeanne Hoffman  
Assistant Professor  
Tamkang University, Taiwan  
Adjunct Fellow in Futures / Futures Studies  
University of the Sunshine Coast, Australia  
Managing Editor, Journal of Futures Studies  
E-mail: jeannehoffman71@gmail.com

## References

- Bauman, Z. (2012). *Liquid Modernity*. Cambridge: Polity Press.
- Bussey, M. (2014). CLA as process: Mapping the theory and practice of the multiple. *Journal of Futures Studies*, 18(4), 45-58. Retrieved from <https://jfsdigital.org/wp-content/uploads/2014/06/Articles3-Bussey.pdf>
- Candy, S., & Kornet, K. (2019). Turning foresight inside out: An introduction to ethnographic experiential futures. *Journal of Futures Studies*, 23(3), 3-22. [https://doi.org/10.6531/JFS.201903\\_23\(3\).0002](https://doi.org/10.6531/JFS.201903_23(3).0002)
- Chen, K.-H. (2016). Linking metaphors of the future with socio-cultural prospects among Taiwanese high school students. *Futures*, 84, 178-185. <https://doi.org/10.1016/j.futures.2016.03.013>
- Chen, K. H., & Hoffman, J. (2017). Serious play: Transforming futures thinking through game-based curriculum design. *Journal of Futures Studies*, 22(2), 41-60. [https://doi.org/10.6531/JFS.2017.22\(2\).A41](https://doi.org/10.6531/JFS.2017.22(2).A41)
- Di Giusto, B., Lavalley, J. P., & Yu, T. Y. (2018). Towards an East Asian model of climate change awareness: A questionnaire study among university students in Taiwan. *PLOS ONE*, 13(10), e0206298. <https://doi.org/10.1371/journal.pone.0206298>
- Dunagan, J., Draudt, A., Hadley, J.J., Hogan, R., Murray, L., Stock, G., & West, J. R. (2019). Strate-

- gic foresight studio: A first-hand account of an experiential futures course. *Journal of Futures Studies*, 23(3), 57-74. [https://doi.org/10.6531/JFS.201903\\_23\(3\).0005](https://doi.org/10.6531/JFS.201903_23(3).0005)
- Galtung, J. (1976). The future: A forgotten dimension. In H. Ornauer, A. Wiberg, A. Sicinki, and J. Galtung (Eds.). *Images of the World in the Year 2000*. Atlantic Highlands, NJ: Humanities Press.
- Hayward, P., & Candy, S. (2017). The Polak game, or: Where do you stand? *Journal of Futures Studies*, 22(2), 5-14. [https://doi.org/10.6531/JFS.2017.22\(2\).A5](https://doi.org/10.6531/JFS.2017.22(2).A5)
- Hicks, D. (1996). A lesson for the future: Young people's hopes and fears for tomorrow. *Futures*, 28(1), 1-13.
- Inayatullah, S. (1998). Causal layered analysis: Poststructuralism as method. *Futures*, 30(8), 815-829.
- Inglehart, R. (1971). The silent revolution in Europe: Intergenerational change in post-industrial societies. *The American Political Science Review*, 65(4), 991-1017.
- IPCC — Intergovernmental Panel on Climate Change. (2018). *Global warming of 1.5°C*. Retrieved April 1, 2019, from <https://www.ipcc.ch/sr15/>
- Kaboli, S. A., & Tapio, P. (2017). How late-modern nomads imagine tomorrow? A causal layered analysis practice to explore the images of the future of young adults. *Futures*, 96, 32-43. <https://doi.org/10.1016/j.futures.2017.11.004>
- Kamijo, Y., Komiya, A., Mifune, N., & Saijo, T. (2016). *Negotiating with the future: Incorporating imaginary future generations into negotiations* (No. SDES-2016-7). Retrieved from Kochi University of Technology, School of Economics and Management website: <https://ideas.repec.org/p/kch/wpaper/sdes-2016-7.html>
- Kress, G., & Van Leeuwen, T. (1996). *Reading images: The grammar of visual design*. New York: Routledge.
- Leiserowitz, A., Maibach, E., Roser-Renouf, C., Rosenthal, S., Cutler, M., & Kotcher, J. (2018). *Climate Change in the American Mind: March 2018*. Yale Program on Climate Change Communication. Retrieved from <http://climatecommunication.yale.edu/publications/climate-change-american-mind-march-2018/2/>
- Liu, S. C., & Lin, H. (2018). Envisioning preferred environmental futures: exploring relationships between future-related views and environmental attitudes. *Environmental Education Research*, 24(1), 80-96. <https://doi.org/10.1080/13504622.2016.1180504>
- Ono, R. (2005). Learning from young people's image of the future: A case study in Taiwan and the US. *Futures*, 35(7), 737-758. [https://doi.org/10.1016/S0016-3287\(03\)00025-9](https://doi.org/10.1016/S0016-3287(03)00025-9)
- Polak, F. (1973). *The image of the future* (E. Boulding, trans. & abr.). Amsterdam: Elsevier.
- Raford, N. (2012). From design fiction to experiential futures. In: A. Curry (Ed.), *The future of futures* (pp.34-38). Houston, TX: Association of Professional Futurists. Retrieved from [https://www.lancaster.ac.uk/social-futures/wp-content/uploads/2015/08/FutureOfFutures\\_APF\\_ebook\\_E2.pdf](https://www.lancaster.ac.uk/social-futures/wp-content/uploads/2015/08/FutureOfFutures_APF_ebook_E2.pdf)
- Riedy, C. (2008). An integral extension of causal layered analysis. *Futures*, 40(2), 150-159.
- Rigitano, E. (2018, December 17). COP24, the speech by 15-year-old climate activist Greta Thunberg everyone should listen to. *LifeGate*. Retrieved from <https://www.lifegate.com/people/news/greta-thunberg-speech-cop24>
- Saijo, T. (2015). *Future Design: Concept for a Ministry of the Future*. Kochi University of Technology, Social Design Engineering Series 2015-14.
- Scher, A. (2018, December 24). 'Climate grief': The growing emotional toll of climate change. *NBC News*. Retrieved from <https://www.nbcnews.com/health/mental-health/climate-grief-growing-emotional-toll-climate-change-n946751>
- Scott-Parker, B., & Kumar, R. (2018). Fijian adolescents' understanding and evaluation of climate change: Implications for enabling effective future adaptation. *Asia Pacific Viewpoint*. <https://>

- doi.org/10.1111/apv.12184
- Solon, O. (2018, Mar 11). Elon Musk: we must colonise Mars to preserve our species in a third world war. *The Guardian*. Retrieved from <https://www.theguardian.com/technology/2018/mar/11/elon-musk-colonise-mars-third-world-war>
- Toffler, A. (1974). *Learning for tomorrow: The role of the future in education*. New York,: Random House.
- Van Leemput, M. (2019). Destinations for polyamorous futures and their MAD lovers. *Journal of Futures Studies*, 23(4).
- Wheelwright, V. (2010). *It's your future... Make it a good one!* Personal Futures Network.
- Wilcox, M. A. (2014). *A study of college student attitudes and behaviors related to recycling* (Doctoral dissertation). University of Northern Iowa. Retrieved from <https://scholarworks.uni.edu/cgi/viewcontent.cgi?article=1001&context=etd>
- Zaleski, Z. (2005). Future orientation and anxiety. In A. Strathman & J. Joireman (Eds.), *Understanding behavior in the context of time: Theory, research, and application* (pp.125-142). Mahwah, NJ: Erlbaum Associates.

# Transforming Environmental Values for a Younger Generation in Taiwan: A Participatory Action Approach to Curriculum Design

Kuo-Hua Chen  
Tamkang University  
Taiwan

---

## Abstract

*This research proposes sustainability-oriented foresight education as a transformative intervention for societies genuinely seeking to create economic and ecological well being for future generations. Taiwan has started to enter a critical stage in developing a more environmentally-minded and futures-oriented worldview. While related prior research mostly emphasizes macro-level institutional change, this study focuses on evaluating the possibilities for encouraging sustainability-consciousness among young citizens through higher education. Students of the course “Environmental Changes and Sustainable Futures” were the participants in a quasi-experimental research design with pre- and post-measurements, and using participatory learning, reflective journals, and scenario workshops as the tools of pedagogical intervention. The results suggest that through a process of integrative learning, a culture of forward-thinking and visioning for sustainable alternative futures is emerging. Most importantly, student participants show promise as potential change agents for creating alternative environmental values and sustainable behaviors.*

**Keywords:** Sustainability, Curriculum Design, Integrated Scenarios, Environmental Values, Images of the Future.

---

## Introduction

Taiwan and other emerging economic tigers in Asia have all been experiencing the awkward phase of cultural lag. In other words, wealth creation has not enabled them to reorient their goals from ensuring basic economic and physical needs to other non-material priorities. This trend must be reversed because Taiwan’s environment has already surpassed its capacity to absorb waste, from plastic to nuclear, the by-products of economic growth.

This points to a major concern: Do values change over time and across societies? The world values survey developed by Inglehart and Baker (2000) has shown that shifts in values are not random, but are brought about by the socialization of successive birth cohorts in a context of economic and physical security. Over the last few decades a gradual increase has been seen in the so-called postmaterialist values, which emphasize individual

autonomy, self-expression and environmental stability at the expense of goals related to economic survival and physical security (Dalton & Welzel, ; Inglehart, 2008; Inglehart & Baker, 20002014; Welzel & Inglehart, 2010). The postmaterialist index in Figure 1 shows Taiwan in the bottom tier with a postmaterialist index of 1.64, in contrast to Hong Kong’s 2.21, Singapore’s 2.11 and South Korea’s 2.05. Except for economic growth, Taiwan is far behind her competitive Asian partners in terms of transforming to sustainable futures.

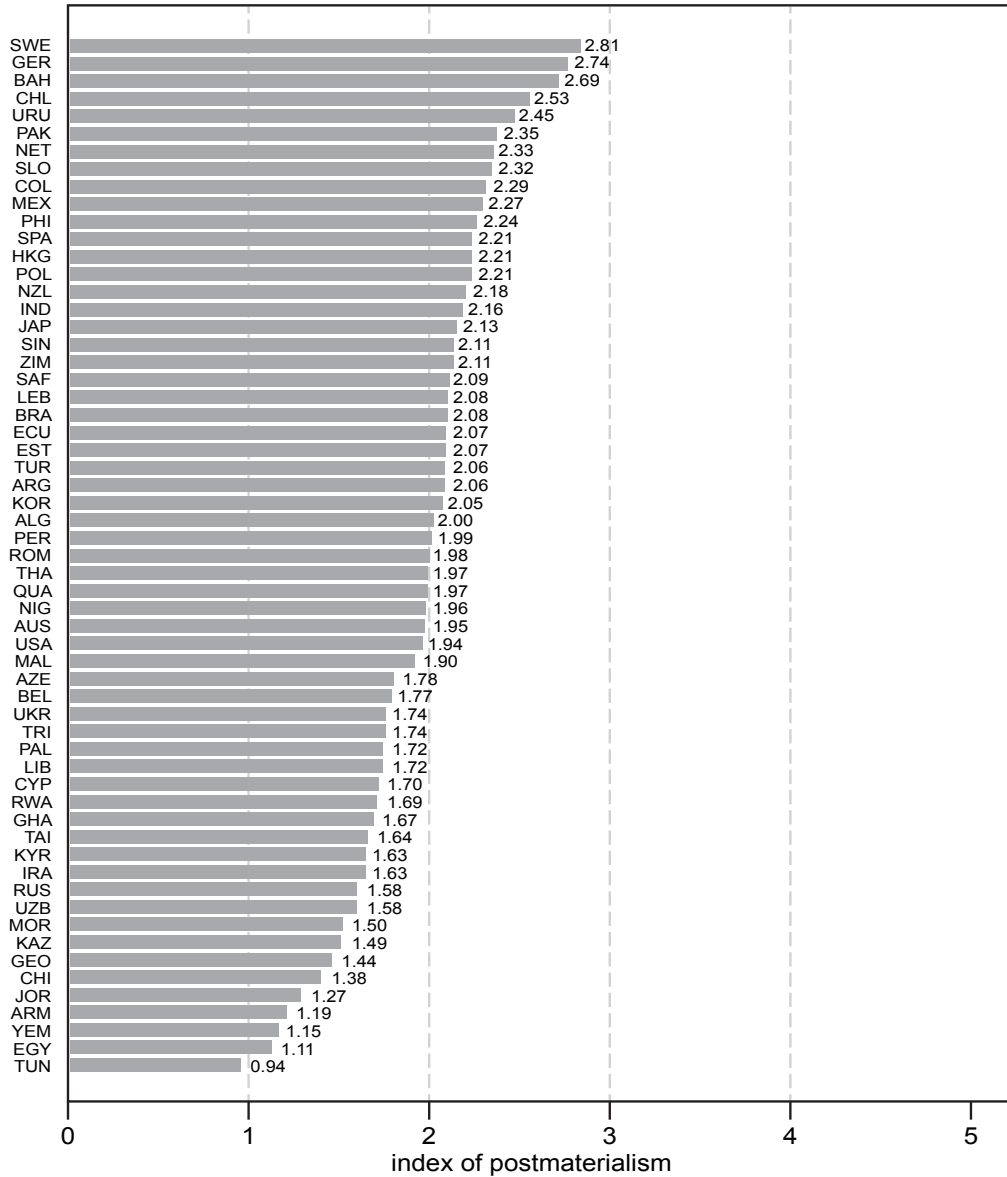

Figure 1. Postmaterialist orientation in 59 countries (mean of index of postmaterialism)

Source: WVS VI (2016)

Tibbs (2011) argues that there is a recognition that global civilization is unsustainable in its present form and must change significantly to survive in the long term. He also illustrates how

changes in cultural values could contribute to achieving sustainability. In order to anticipate change, the younger generation of Taiwanese will need to foster a deeper understanding of the nature of change, including emerging issues that specifically characterize environmental change, and the forces that create and drive such change. Sterling (2001) states it well: sustainability education is a transformative learning response that subsumes education about sustainability (facts) and education for sustainability (values and capacities) into a “reflective and participatory process.” Novy, Smith and Katrnak (2017) find that postmaterialist values are inversely correlated with age; younger respondents are more postmaterialist than older respondents. Furthermore, a university education strongly encourages postmaterialist values, which supports their hypothesis that the feeling of existential security is crucial for preferring postmaterialist goals (McNamara, 2010). Accordingly, our own hypothesis is that pedagogical intervention, an educational approach to building young students’ environmental values, might create a positive contribution to Taiwan’s alternative sustainable futures.

### Education for Sustainable Foresight

To further adapt to sustainable futures, Taiwan needs to transform its environmental values to enter the critical stage of a more alternative, environmental and cultural-spiritual, future generation-orientation. The situation could become more complex still if we have to go through a chaotic progression of Image Lag, a concept coined by Markley and Harman in 1982. Theirs was the first known formal study applying Thomas S. Kuhn’s ideas about ‘paradigm change’ to a whole society, and in which it envisioned a paradigm change from the guiding image of economic growth to something more ecologically sustainable—a vision that seems increasingly needful, but that is probably not actionable until societal crises necessitate it. When images ‘lead’ social development they are anticipatory, and provide direction for social change. When images are in this relation to society they exert what Polak (1973) termed a ‘magnetic pull’ toward the future, influencing the social decisions which will bring them to realization (See Figure 2).

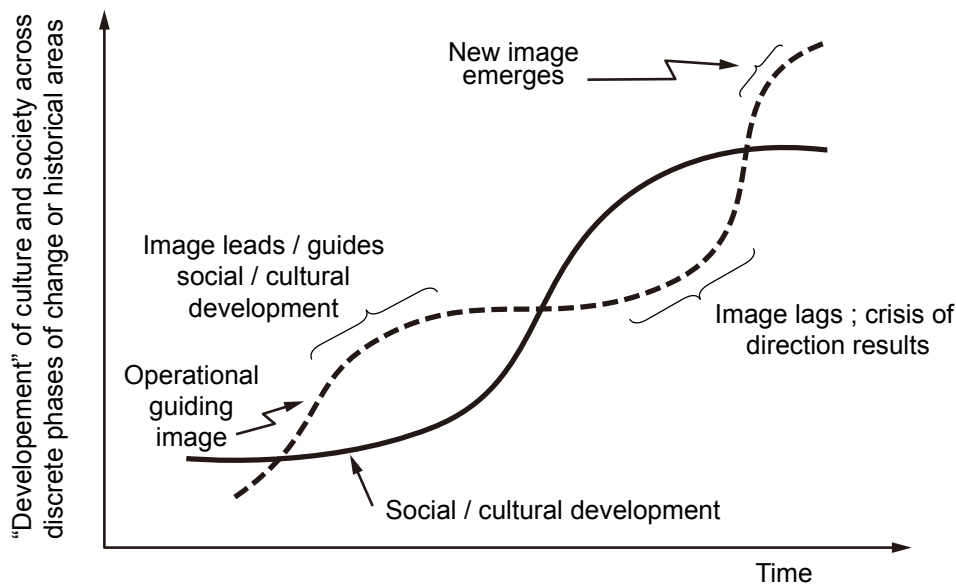

Figure 2. Hypothesized time/phase relationship between images and social/cultural development

Source: Markley and Harman, 1982, *Changing Images of Man*, p.5

Young Taiwanese high school students were concerned about what follows after achieving the economic miracle, and appeared willing to transform the current poor political ecology in Taiwan (Chen, 2016). Liu and Lin (2016) also found that many Taiwanese students would like to see a future based on greater environmental awareness and actions involving techno-scientific advancements. Moreover, their findings suggested that students desire better environmental quality (e.g. clean air and water), presence of nature, and the use of harmonious technologies (e.g. green energy, underground transportation systems) in support of comfort and livability, including positive attitudes regarding environmental factors such as trees over buildings, global warming awareness, and alternative energy sources. Liu (2019) concluded that, as the incorporation of futures thinking in science and environmental education remains relatively underexamined, more research along these lines is needed to provide the basis for curricular and instructional development.

Nonetheless, several other studies indicate that young people tend to be more pessimistic regarding our capacity to solve environmental problems. Strife (2011) found that urban children in the US mostly held negative views of the Earth's future, especially through apocalyptic visions of natural disasters. Fleer (2002) investigated attitudes of Australian children and found that the older the children, the less positive they felt about the future environment. Ojala's research (2012) with Swedish young people revealed that students' hopes for solving environmental problems may be based on denial, which in turn becomes a barrier to pro-environmental behavior. A study conducted among Finnish ninth grade students investigating their knowledge and perceptions of bioenergy (Halder, Pietarinen, Havu-Nuutinen, & Pelkonen, 2010) found a lack of in-depth knowledge about renewable energy sources, including bioenergy, as well as critical perceptions of it.

Above all, educational settings including colleges and universities are responding to this call for leadership by starting or expanding environmental research programs. McNamara (2010) completed a thorough research project across 86 colleges and universities in the United States that have implemented sustainability initiatives. This investigation concluded with a list of recommended strategies and suggested methods for implementing them. Two are particularly relevant to this research: to build a strong student commitment and engage more people; and to try including everyone to be part of a continuing effort. However, the perceptions of academics and students towards embedding Education for Sustainable Development (ESD) into undergraduate degree programmes were found to be conflicting (Jones, Trier, & Richards, 2008). The results indicated general support for the embedding of ESD in the curriculum, but also considerable uncertainty concerning how this can best be done.

## Curriculum and Research Design

### Educational intervention

This research attempts to apply an anticipatory learning and futures design approach to educational intervention to explore the possible effects of transforming young students' environmental values. Chen and Hoffman (2017) have successfully applied an experimental and innovative game-based curriculum design in enhancing college students' learning capacity outside their major subjects. Applying reflective journals as a core pedagogical intervention, Kelly (2006, 2010) provided constructive insights that students' actions and attitudes, in a tertiary educational system, are transferable to a less economically driven, peaceful and spiritually oriented way of living.

"Environmental Changes and Sustainable Futures" is an elective general education course. Its core objective is to inquire into students' preferred futures, and to further explore alternatives and possibilities along their desired trajectories, by linking foresight strategies with long-term socio-cultural prospects of the society. Accordingly, this course was designed as one educational intervention to evaluate the effects of environmental futures thinking, and as an attempt to bridge

the gap between environmental attitudes and ecological behaviors. The following stimuli were introduced during the 18-week course:

1. *Thematic discussions* on emerging issues (time horizon 2030) of ecology, population, food and water resources, minerals and energy, air, water environment and waste, transportation, natural resources, regional environment, etc. This preparation phase aimed to arouse students' environmental consciousness.
2. *Reflective journals*. Students were asked to write reflectively after class, addressing several questions: a) Which issue has touched your mind most deeply? b) What images/discussions have challenged your viewpoint/perspective? c) What are the most effective ways to ensure sustainable development of the world? d) Would you be eager to read more related news/discussions concerning natural resources and ecology? e) Would you be willing to go outside to experience and learn more about the natural environment?
3. *Environmental volunteering*. Students were also asked to form groups (5-7 people) to take part in an environmental protection activity for half a day during the second half of the class (See Figure 5). Each having a concrete ecological goal in mind, activities included beach cleaning, tree planting, resource recycling, waste reduction and reuse, wetland preservation, alternative uses of disposable tableware, protecting mangrove forest, experiencing vegetarianism, and biking in nature.
4. *Presentations and scenario workshops*. Students presented their 'field volunteering activities' in four major dimensions: 1) Why is the chosen environmental activity important to people of the future? 2) How did we plan and organize it? 3) What were the major findings from the research? 4) What were the key learnings? Discussions and scenario workshops envisioning students' changing knowledge, values and behaviors for future generations followed their presentations.



Figure 3. Students' environmental volunteering activities in the wetland and forest



Figure 4. Group discussions and workshops

### Research questions

Young citizens of global society are a vital stakeholder group, perhaps more receptive to new concepts and able to be activated as change agents to promote environmental values. What takes place in the future depends on how the instruments developed today are used, and on the planning that is done in the present for years ahead. Consequently the research aimed to explore possible transformations of attitudes and roles through pedagogical stimulus in sustainable foresight, guided by four major questions:

1. What are university students' general attitudes toward environment and sustainable futures?
2. Do their attitudes change significantly with pedagogical stimulus of sustainable foresight?
3. What are the images and scenarios of their preferred future environments?
4. Do the interventions help them become more aware and able to think critically and assume responsibility for themselves and their environmental impact?

## Evaluation, Results and Discussion

### Methods

The research design was quasi-experimental with pre- and post-measurements, but without control group/random assignment of experiment group. Students who took the general education course "Environmental Changes and Sustainable Futures" were the participants. The quantitative data used in this research was collected in the years 2015-2016, through surveys of environmental changes and sustainable futures. A total of 40 items was included, 8 addressing socio-demographic characteristics and general knowledge questions, and 32 items using a 5-point Likert scale, scored from 1 (totally disagree) to 5 (totally agree) and 3 indicating 'neutral'. The reliability of the 32 items was tested by using Cronbach's alpha, which showed a satisfactory level of internal consistency ( $\alpha=0.71$ ); a reliability coefficient of 0.70 or above is usually considered acceptable (Taber, 2018).

The research applied a multi-method and participatory learning approach to triangulate the investigation. Major findings of the quantitative surveys, including pre- and post-testing, were followed by qualitative data gathered from students' reflective journals. Possible scenarios generated from workshops will be discussed at the end.

### Socio-demographic characteristics and general environmental knowledge

A sample of 223 student respondents was included for the analysis, coming from a wide range of majors. As Table 1 shows, respondents are equally distributed in terms of gender (51 percent female, 49 percent male) and ages ranging from 18-22. Most of the respondents (88 percent) live in the Taipei metropolitan area, mostly with family (71 percent). In terms of energy awareness, unsurprisingly, solar and hydro gain nearly 85 percent of attention. While Taiwan has abundant wind power and great bioenergy potential, both are relatively underestimated. Respondents' self-rated

knowledge levels regarding bioenergy lean toward poor, with only 14 percent responding ‘good’, and none at all responding ‘very good’.

Table 1. *Respondents’ socio-demographic characteristics and general knowledge (N=223)*

Variables	Categories	Frequency	Percentage
Gender	Male	109	48.9
	Female	114	51.1
College	Literature	23	10.3
	Engineering	81	36.3
	Business/Management	76	34.1
	Foreign Language	43	19.3
Class level	Freshman	2	0.9
	Sophomore	83	37.2
	Junior	105	47.1
	Senior	33	14.8
Residence	Urban	130	58.3
	Suburb	66	29.6
	Rural	27	12.1
Living with whom	Apartment with family	117	52.5
	House with family	41	18.4
	Alone apartment	41	18.4
	Friends apartment	24	10.8
Most important renewable energy	Solar	98	43.9
	Wind	1	0.4
	Hydro	90	40.4
	Bio	34	15.2
Taiwan’s Major source of energy	Oil	38	17.0
	Coal	60	26.9
	Hydro	36	16.1
	Wind	4	1.8
	Nuclear	85	38.1
Knowledge of Bioenergy	Very good	0	0
	Good	32	14.3
	Cannot say	102	45.7
	Poor	82	36.8
	Very poor	7	3.1

The results show students exhibiting strong misconceptions about Taiwan's major energy sources. Over a third (38.1 percent) believe nuclear to be the main source; whereas according to Taiwan Power Company, in 2016 oil and gas accounted for 40 percent of the total energy consumption in Taiwan, followed by coal at 37 percent, nuclear energy at 13 percent, and 10 percent from various renewable sources (see Figure 5).

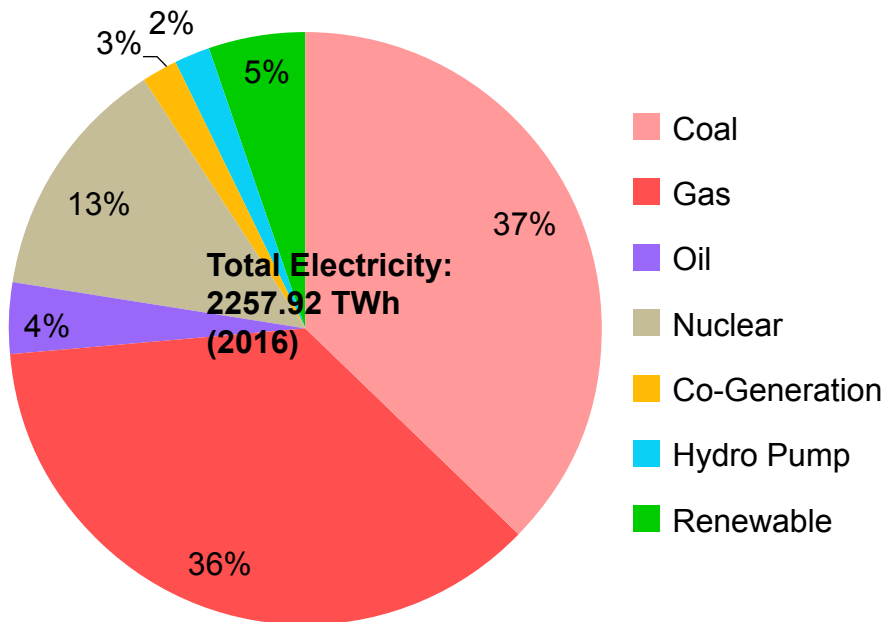

Figure 5. Taiwan's electricity generation, 2016

Source: Taiwan Power Company

### General environmental attitudes, values and behavior intentions

At the very beginning of the class, the students were provided with a 32-item Likert scale survey to measure (pre-test) their general attitudes toward sustainability and the environment. Three questions were stated negatively (items 23, 25, 32) to reiterate similar perceptions and enhance reliability. The results are shown in Figure 6. The most encouraging finding, contrary to respondents' relatively low levels of environmental knowledge, is that students exhibit a sense of agency (item 31, mean=3.25), believing that change is possible, and that good ecological futures can be created by changing their behaviors. Similarly, they do not believe that the problems facing sustainability are too complex to be resolved (item 32, mean=2.08, negative statement). Four items show strong positive responses (mean >4) toward better environmental futures:

Q2. Efficient use of energy can cut carbon emission and save the earth (4.18)

Q6. Carbon taxes are fair and justified (4.16)

Q13. We should not produce bioenergy by means of deforestation (4.31)

Q15. The Taiwanese government should support research and development of bioenergy (4.07)

Two other negatively-stated questions show equally important results:

Q23. Natural resources are not important to me (1.61)

Q25. Economic development and survival issues are far more important than protecting endangered species (2.07)

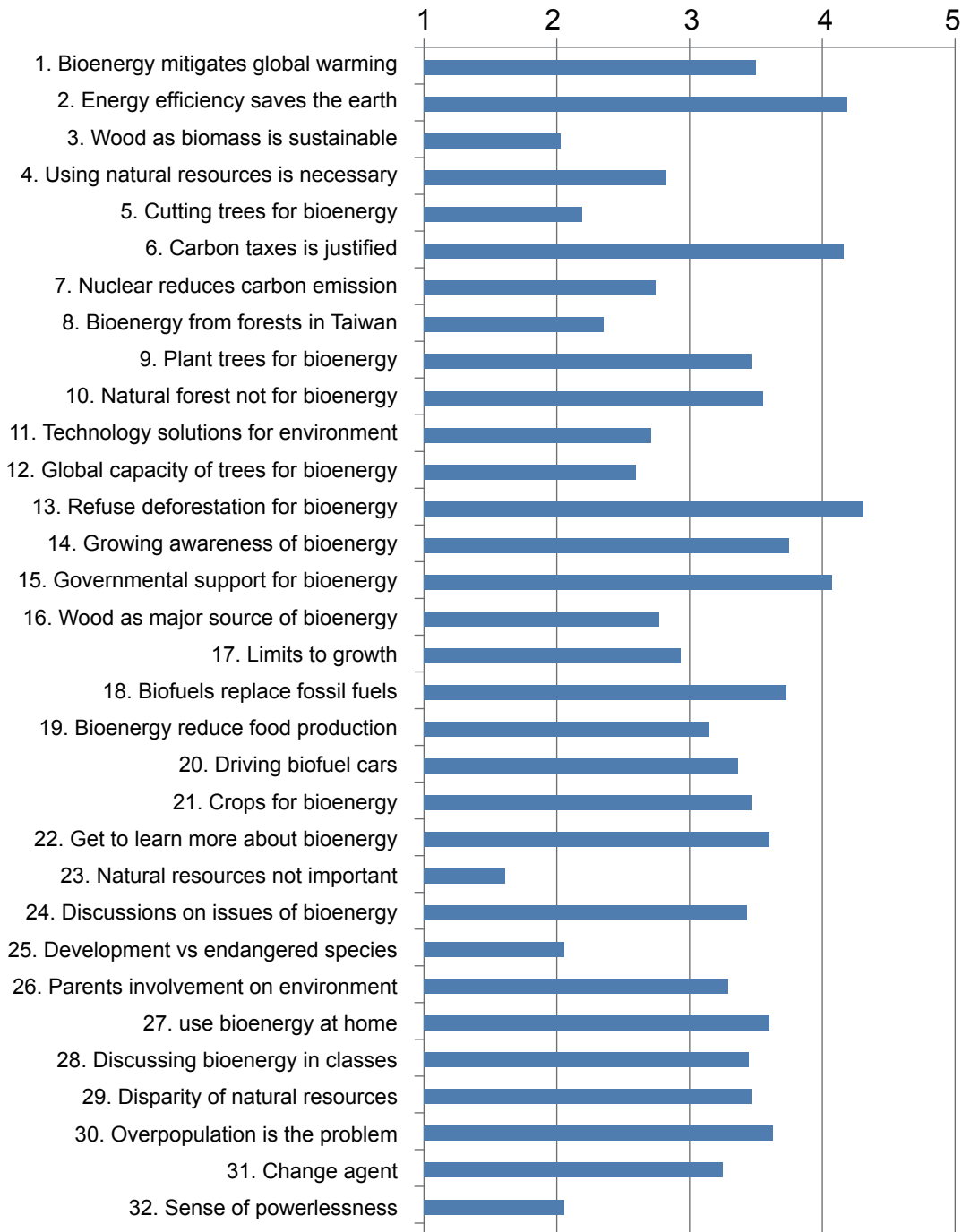

Figure 6. Mean scores of respondents' environmental attitudes

**Socio-demographic differences on environmental attitudes and values**

To further determine whether there were statistically significant differences according to gender (male=1, female=2), college (literature, language and business=1, engineering=2) class level (junior

and senior=1, freshman and sophomore=2), and living area (urban=1, suburb and rural=2), on the students' attitudes and values of environment and sustainability, an independent sample t-test was applied. The results are presented in Table 2. One of the most consistent findings reported in the public opinion literature since the 1970s is that women are more opposed to nuclear power than men. Brody (1984) found that, compared with men, women tend to believe that nuclear plants are less safe, and evaluate a number of problems with nuclear power as being more serious, particularly those involving danger to hearth and human life. A more recent survey (Burroughs, 2015) found that a plurality of female respondents, 42 percent, oppose increasing the use of nuclear power to generate electricity in the United States; while 38 percent support it. A strong majority of men, 70 percent, support using more nuclear power, while 23 percent oppose. Clearly, the male-female gap is particularly wide on this issue of energy preference.

To explore gender-based differences between the students surveyed, this research tested the question statement, "To reduce carbon emissions, it is reasonable and necessary to develop nuclear power." Our results show that males have a higher approval mean than females (2.84/2.65); yet the difference is not statistically significant ( $p=.141$ ). Statistically significant results were found in three question statements: 1) Cutting trees for energy production is justified ( $t=1.95$ ,  $p<.05$ ), with a male/female mean score difference of 2.32/2.09; 2) Economic development and survival issues are far more important than protecting endangered species ( $t=2.87$ ,  $p<.01$ ), with males exhibiting a much stronger tendency to support economic development over endangered species (2.28/1.87); and 3) Female students tend not to believe that the problems facing sustainability are too complex to be resolved ( $t=2.53$ ,  $p<.05$ ), while conversely, male students reported a much higher sense of powerlessness in facing environment and sustainability issues (2.26/1.91).

A comparison was also applied across students' academic focus areas. As Kelly (2010) suggests, engineers' attitudes are significant because their discipline has enormous impacts on the global environment; they are often regarded as narrow-minded thinkers operating within a paradigm of domination over nature, which has led to complicity in unsustainable projects with little concern for ecological or human impacts. This study categorized respondents of literature, language and business college into non-engineering (recoded as 1) comparing with students from the engineering college (recoded as 2). The results show statistically significant findings in five question statements. As hypothesized, non-engineering students show stronger agreement that efficient uses of energy can cut carbon emissions and save the earth ( $t=2.82$ ,  $p<.01$ ); they also considered carbon taxes to be fair and justified ( $t=2.60$ ,  $p<.01$ ) and that we should not produce bioenergy by means of deforestation ( $t=2.52$ ,  $p<.05$ ). Engineering students tend to support the statement that sustainability problems are too complex to be resolved ( $t=1.93$ ,  $p<.05$ ), and show a much higher sense of powerlessness when facing environment and sustainable issues ( $t=-2.3$ ,  $p<.05$ ).

Comparisons in terms of class level show significant results for three questions. Freshman and sophomore students (recoded as 2) agree more with the statements that efficient use of energy can cut carbon emission and save the earth ( $t=-2.3$ ,  $p<.05$ ) and that cutting trees for energy production is justified ( $t=-2.1$ ,  $p<.05$ ), while juniors and seniors agree more with the statement that economic development and survival issues are far more important than protecting endangered species ( $t=2.16$ ,  $p<.05$ ). The dimension of where students live (recoded urban=1, suburb and rural recoded=2) produces the least statistically significant results, merely showing contrasting perceptions around the statement that natural forests should not be used to produce energy ( $t=2.84$ ,  $p<.01$ ); urban-residing students tend to care more about sustaining forests.

Table 2. *Comparisons of attitudes of sustainable foresight by socio-demographic characteristics*

Scale questions	T-test statistics (two-tailed test)							
	Gender		College		Class level		Living area	
	t	Sig.	t	Sig.	t	Sig.	T	Sig.
Bioenergy mitigates global warming	.082	.934	.864	.389	-.878	.381	.641	.522
Energy efficiency saves the earth	-1.70	.090	2.82*	.005	-2.3*	.020	-1.06	.287
Wood as biomass is sustainable	.396	.692	-1.13	.256	-1.16	.247	1.248	.213
Using natural resources is necessary	1.35	.178	.133	.895	-.735	.463	-.461	.645
Cutting trees for bioenergy justified	1.95*	.050	-.445	.656	-2.1*	.038	-1.47	.252
Carbon taxes is justified	-.618	.537	2.60*	.010	-.206	.837	.417	.677
Nuclear reduces carbon emission	1.48	.141	-.675	.500	-.939	.349	-1.13	.259
Bioenergy from forests in Taiwan	-.691	.490	-.737	.462	-.429	.668	-.833	.406
Plant trees for bioenergy	-1.77	.078	1.290	.198	-.521	.603	-1.02	.311
Natural forest not for bioenergy	.309	.758	-.029	.977	.336	.737	2.84*	.005
Tech solutions for environment	1.477	.141	-.084	.933	.719	.473	-.811	.418
Capacity of trees for bioenergy	-.617	.538	.243	.808	-.196	.844	-1.81	.072
Refuse deforestation for bioenergy	-1.68	.094	2.52*	.012	-1.28	.202	.177	.860
Growing awareness of bioenergy	-.090	.928	1.133	.258	-.495	.621	.781	.435
Governmental support for bioenergy	-1.64	.101	1.130	.260	-.271	.787	-.235	.815
Wood as major source of bioenergy	.496	.621	-.171	.864	1.736	.084	-1.75	.081
Limits to growth	-1.42	.155	.514	.608	1.250	.212	-1.45	.150
Biofuels replace fossil fuels	1.266	.207	-1.33	.185	-.540	.590	.072	.943
Bioenergy reduce food production	1.058	.291	.428	.669	-1.66	.099	.037	.971
Driving biofuel cars	1.354	.177	.637	.525	-.790	.430	.346	.730
Crops for bioenergy	-.531	.596	.261	.794	-.121	.904	.813	.417
Get to learn more about bioenergy	-.001	.999	-.389	.698	-1.14	.256	1.312	.191
Natural resources not important	1.560	.120	-1.25	.212	.232	.816	-.047	.962
Discussions on issues of bioenergy	-.312	.755	1.157	.249	1.248	.213	1.698	.091
Development vs endangered species	2.87*	.004	-1.63	.105	2.16*	.032	-1.47	.155
Parents involvement on environment	-1.42	.155	.533	.595	-.095	.924	.980	.328
Use bioenergy at home	-1.58	.115	1.491	.137	.846	.398	-.260	.795
Discussing bioenergy in classes	-.288	.772	.019	.984	.177	.860	1.143	.254
Disparity of natural resources	.597	.551	1.639	.103	-1.12	.266	-.629	.530
Overpopulation is the problem	.951	.342	.093	.926	1.083	.280	.970	.333
Change agent	-1.16	.245	1.93*	.050	.130	.897	.939	.349
Sense of powerlessness	2.53*	.012	-2.3*	.026	.786	.433	.065	.948

\*Significant, p<.05

### Assessing the influences of educational stimuli on sustainable foresight

Pre- and post-testing was conducted in an effort to evaluate possible changes in students' environmental attitudes and values owing to the educational interventions. These can be grouped into two dimensions (Table 3). The first is students' environmental values, which we tie to the potential for a macro-cultural change in the long term, with the study of alternative futures emphasizing agency; that is, young people's sense of their own capacity to affect social change. The results on this front suggest that students do seem to be more oriented to the positive exercise of agency in relation to environmental challenges. By the end of the semester, more students appear to believe that the sustainability problems are *not* too complex to be resolved ( $t=2.56$ ,  $p<.05$ ). Additionally, they report a lower sense of powerlessness (or to state it the other way around, an increased sense of empowerment) when facing environment and sustainability issues, with nonsignificant t-value, but mean scores dropping from 2.08 to 2.0. Nonetheless, more students agree less with the idea of discussing bioenergy issues with professors ( $t=-2.686$ ,  $p<.01$ ). The second dimension more specifically concerns energy and natural resources, with results showing that students agree more with the statement that production of energy from wood is environmentally friendly ( $t=2.489$ ,  $p<.05$ ). On the other hand, they tend not to approve tree plantations being established for bioenergy production ( $t=-2.253$ ,  $p<.05$ ). Finally, it is worth noting that the statement "We should have set limits to economic growth in developing countries to protect future environment of earth" shows a nearly significant result ( $t=1.824$ ,  $p=.069$ ).

Table 3. Measurement of pre- and post-test of attitudes of sustainable foresight

Scale questions	Independent t-test statistics (two-tailed test)					
	Mean		SD		t	Sig.
	Pre-	Post-	Pre-	Post-		
Bioenergy mitigates global warming	3.50	3.45	1.21	1.20	-.409	.683
Energy efficiency saves the earth	4.18	4.04	1.03	1.12	-1.465	.143
Wood as biomass is sustainable	2.03	2.27	1.04	1.03	2.489*	.013
Using natural resources is necessary	2.83	2.80	1.10	1.12	-.231	.817
Cutting trees for bioenergy	2.20	2.26	0.92	1.10	.576	.565
Carbon taxes is justified	4.16	4.21	1.11	1.09	.492	.623
Nuclear reduces carbon emission	2.74	2.76	0.99	0.98	.179	.858
Bioenergy from forests in Taiwan	2.37	2.24	1.08	1.13	-1.281	.201
Plant trees for bioenergy	3.67	3.46	1.01	1.03	-2.253*	.025
Natural forest not for bioenergy	3.55	3.56	1.03	1.08	.149	.881
Tech solutions for environment	2.72	2.69	1.03	0.98	-.334	.739
Capacity of trees for bioenergy	2.61	2.48	1.08	1.16	-1.207	.228
Refuse deforestation for bioenergy	4.31	4.19	0.94	1.18	-1.137	.256
Growing awareness of bioenergy	3.75	3.61	0.96	1.05	-1.477	.140
Governmental support for bioenergy	4.07	3.99	0.97	1.07	-.884	.377
Wood as major source of bioenergy	2.78	2.87	0.93	0.96	.970	.333
Limits to growth	2.94	3.11	0.96	1.06	1.824	.069

Biofuels replace fossil fuels	3.73	3.67	0.83	0.93	-.700	.484
Bioenergy reduce food production	3.15	3.19	0.87	0.97	.537	.592
Driving biofuel cars	3.37	3.40	0.94	0.99	.285	.776
Crops for bioenergy	3.46	3.40	0.84	0.91	-.771	.441
Get to learn more about bioenergy	3.60	3.51	0.88	0.91	-.987	.324
Natural resources not important	1.61	1.72	0.86	1.08	1.253	.211
Discussions on issues of bioenergy	3.44	3.23	0.81	0.83	-2.686*	.008
Development vs endangered species	2.07	2.18	1.07	1.04	1.098	.273
Parents involvement on environment	3.29	3.25	0.87	0.92	-.412	.681
Use bioenergy at home	3.60	3.60	0.76	0.90	.068	.946
Discussing bioenergy in classes	3.45	3.40	0.87	0.96	-.531	.596
Disparity of natural resources	3.47	3.61	1.16	1.20	1.298	.195
Overpopulation is the problem	3.63	3.62	1.07	1.08	-.082	.935
Change agent	3.25	3.50	1.02	1.07	2.564*	.011
Sense of powerlessness	2.08	2.00	1.03	1.12	-.797	.426

\*Significant,  $p < .05$

### Qualitative environmental attitude and values

Applying quantitative analysis, these results show the surveyed university students' general attitudes toward environmental issues and sustainable futures, and indicate that some of their attitudes change significantly with the pedagogical intervention themed around sustainability and foresight.

In addition to the above, this research design also sought to probe students' images of their preferred future environments in a qualitative mode, exploring how they become more aware and able to think critically and assume responsibility for themselves and their impact on the environment. The results reported here come from the reflective journals and workshop discussions. Students' opinions and voices can be generally summarized into four dimensions:

#### 1. Outdoor experience is a catalyst for the desire to learn more about nature

Most of Taiwan's university students are confined during their learning to indoor classrooms, and their daily class schedule is relatively tight. As some students put it:

*My life goes on in a fast-forward mode and I have to rush into the next thing, day in and day out. Suddenly, after a most impressive journey into nature, I realized that there are lots of people devoted to the important idea of sustainable development...*

*Activity-based learning is really a great way of learning. I can share and feel what we can do to the environment.*

Others start to reflect back and admit that their lack of knowledge was a great barrier to greater engagement with the nature. Considering their scarce leisure time, some students even state that "I would not mind having outdoor classes on weekends." One concludes:

*It really was a shocking and amazing experience when we were biking along the river to actually enter the mangrove forest. I was so touched, seeing bouncing fish, fiddler crabs, and egrets with my own eyes, rather than on a screen. Embracing nature does bring me great happiness that I have rarely experienced.*

## 2. Linking motivation with reflexive thinking

The digital-native generation was born at a time when change — technological, cultural, spiritual, ecological — is endemic. In particular, a major change in environmental awareness is necessary. Some of their thoughts are quite profound:

*Technological advancement will never catch up with humans' powers of environmental destruction.*

*My worldview was broadly expanded knowing that environmental protection requires a global effort.*

The field experience not only transformed students' minds, but also touched their hearts. Seeing what past generations have done to replace natural environments and plant and animal habitats with drastic expansion of highways, skyscrapers, and urban metropolitan area, their perceptions change:

*Compared to the precious natural resources we have in Taiwan, Taipei 101, the tallest building, is nothing to be proud of. There are a lot of things that are more worth pursuing than high-tech and wealth.*

*We all have to look at the sustainable earth from a much different angle. I would not mind retaking the class and leading the discussions.*

## 3. Agency and social responsibility

The capacity for creating new ecological futures requires a that change be considered possible — that students have agency, and that good futures can be created. The quantitative measures show a strong and positive momentum for change, supporting the hypothesis that capacity for agency may be strengthened via futures-oriented educational interventions. In students' words:

*I like the idea of corporate social responsibility. It is a win-win solution not only to the economy but also feedback to nature.*

*We all need to maintain the perception of sustainability, and preserving nature is not just the responsibility of environmental protection groups. Each one of us is never too small to make a difference.*

*After knowing that livestock farming is seriously harming water resources and increasing risk of global warming, I am willing to eat less meat and hopefully the government policy will adapt to changes.*

## 4. Vision and dream of the future society

The qualitative results show students constantly questioning not just their values and empirical views of the nature of the world, but also the paradigms that inform these positions. They are integrated, seeing the links between the external world and the internal world, individual and society. A few students pessimistically observe that “the earth might be better without us.” But most

others seem to be inspired by the dreams of artists and community leaders, asking for nature-based classrooms, more participation, and more opportunities for their voices to be heard:

*I was deeply inspired by the documentary film, The Man Who Plants Trees. It is about a young Taiwanese artist who learned the dream from Paris and determines to plant trees along Tropic of Cancer in southern Taiwan to enrich life with nature in local communities.*

*We have to explore alternative and renewable resources on the condition that the natural environment will not be harmed.*

## **Integrated visioning and scenarios of sustainable foresight**

The present research incorporates the ‘integrated’ scenario generation and visioning method (Inayatullah, 2015), which analyzes and integrates various dynamic elements in the development of visions of the future. The method’s value is in surfacing aspects of our thinking and action that are currently ‘disowned’ or rejected; and in bringing these back explicitly into the development of an ‘integrated’ vision of the future (a preferred scenario; the world we want), where owned and disowned are united in a complex fashion. The last is the ‘outlier’, a future outside of these categories.

### **Preferred future: Nature-based partnership learning**

‘Nature-based partnership learning’ is the preferred future for students. The students simply cannot be satisfied with exam-based traditional assessment and curriculum design based on jobs from the past. Traditional classroom education doesn’t provide ways for students to actually see, feel and know environment around them, hence they would prefer to see courses designed with vibrant foresight and flexible pedagogical styles. Partnership learning emphasizes taking the views and voices of students seriously. In a world full of disruptive change and future surprises, the desires and dreams of the younger generation deserve abundant opportunities to flourish. This emerging class desires images beyond safety and security, pursuing a niche in which they can excel and really experience ecological ways of life. Most importantly, they wish to co-create futures with the nature surrounding them.

### **Disowned future: Just follow the rules**

‘Just follow the rules’ is the disowned future. As one student said, “the future and natural wonders are two things that I have cared about the most, but I am not used to appreciating them in combination.” Similarly, most of the students found the effects of traditional education somewhat unreal, and that it reduces the ability to learn. Another expressed concern about wasting time and energy going from class to class without a clear learning goal. Face-to-face interaction and participatory action learning are the most important thing. Some students are feeling quite powerless to negotiate with previous generations. The world outside of them is still in the industrial mode of knowledge, and appears mostly to cater to the needs of their parents (safety, security and elite status). On the other hand, students are trying to express their own needs; joining with the natural environment, the freedom of pursuing their dreams, and the exercise of social responsibility in sustainable ways of life.

### **Integrated future: A HEALTHIER society**

‘A HEALTHIER society’ is the integrated future. Lowe’s vision (2008) corresponds perfectly to students’ perceptions of responsible sustainability: it is a vision that is Humane, takes an Eco-

centric approach, adopts Long-term thinking, uses our natural resources responsibly, is Informed about the fragility of our natural systems, is Efficient in turning resources into the services we need and is Resourced from natural flows of energy. During the workshops many students expressed their worry that we are consuming the future: if we and generations to come do not adopt a radical re-thinking of the way we live, our society is doomed. Lowe further explains that we need to tackle this problem head-on and develop far-reaching solutions to our environmental and social crisis. This does not just require technical innovation; it also demands fundamental changes to our values and social institutions.

### **Outlier future: A postmaterial society**

A postmaterial society is the outlier. It took a few decades for East Asian countries to move up the economic ladder, at great expense to natural resources, the environment, and quality of life. Worst of all, the present game of economic competition only guarantees that everybody loses in the long run. Therefore, the stories guiding sustainable environment and development have to make a disruptive shift. Inayatullah (2018) suggests that this story shift is not just historical, from the agricultural worker to industrial worker to the gold-collar knowledge worker, but archetypal; to the wanderer, creating value through novel insight. The young students engaged in this study reflect that what most stimulated their thinking was facilitated by the society of wilderness, by direct encounters with nature itself. Their stories were of sharing, action and change appear to promise great help and support to future wanderers in their quest to create new dreams.

## **Conclusion**

The major objective of the futures curriculum design, and the multi-method research approach described here, was to explore the ambitious possibility of encouraging an emerging culture of sustainable foresight via the conscious design of educational stimuli for students. The undergraduates who took the course “Environmental Changes and Sustainable Futures” were the major participants in our quasi-experimental research design, with pre- and post-measurements, and without control group/random assignment of experiment group. Applying a participatory action learning approach, the use of educational intervention tools was multifold, incorporating environmental volunteering activities, reflective journaling, and scenario workshops. The core research question was, “Do students become more aware and able to think critically and assume responsibility for themselves and their impact on the environment?”

The most encouraging result was that through the interventions these students do indeed appear to develop an alternative mindset, playing positive-agency oriented roles: by the end of semester they significantly agree that the sustainability challenges are not too complex to be resolved, and their sense of powerlessness diminishes in relation to environmental issues. The study also finds that they are optimistic and enthusiastic regarding better environmental futures, and that they are eager to learn sustainable foresight and alternative futures. All of this appears to equip them to more effectively challenge the current development paradigm with environmental values.

Results of the qualitative participation- and discussion-based portion of the study also indicated that the research participants are enabled through their engagement with futures to envision an integrated, healthier society, and take steps toward becoming designers of their preferred futures, seeking to co-create sustainable futures with nature. It is crucial to cultivate the younger generation’s preference for postmaterialist values and goals over economic and materialist gain. Through foresight-based educational intervention, the youth of today appear better able to articulate and pursue their preferred visions, a critical capability for any society genuinely seeking to foster economic and ecological well-being for future generations.

## Acknowledgements

This work was supported by the National Research Foundation of Korea. Grant funded by the Korean Government (NRF-2017S1A3A2065772). Special thanks to two anonymous reviewers for their input and suggestions that helped to improve the manuscript.

## Correspondence

Kuo-Hua Chen, PhD  
Graduate Institute of Futures Studies  
Tamkang University, Taiwan  
E-mail: sochen@mail.tku.edu.tw

## References

- Brody, C. (1984). Differences by sex in support for nuclear power. *Social Forces*, 63(1), 209-228.
- Burroughs, D. (2015, May 24). Men and women divided on nuclear power. *Morning Consult*. Retrieved from <https://morningconsult.com/2015/05/24/men-and-women-divided-on-nuclear-power/>
- Chen, K. H. (2016). Linking metaphors of the future with socio-cultural prospects among Taiwanese high school students. *Futures*, 84, 178-185.
- Chen, K. H., & Hoffman, J. (2017). Serious play: Transforming futures thinking through game-based curriculum design. *Journal of Futures Studies*, 22(2), 41-60.
- Dalton, R. J., & Welzel, C. (2014). Political culture and value change (pp. 1-16). In R. J. Dalton & C. Welzel (Eds.). *The civic culture transformed: From allegiant to assertive citizens*. New York: Cambridge University Press.
- Dannenbergh, S., & Grapentin, T. (2016). Education for sustainable development – learning for transformation: The example of Germany. *Journal of Futures Studies*, 20(3), 7-20.
- Fleer, M. (2002). Curriculum compartmentalisation? A futures perspective on environmental education. *Environmental Education Research*, 8(2), 137-154.
- Halder, P., Pietarinen, J., Havu-Nuutinen, S., & Pelkonen, P. (2010). Young citizens' knowledge and perceptions of bioenergy and future policy implications. *Energy Policy*, 38, 3058-3066.
- Inayatullah, S. (2015). *What works in futures studies*. Taipei: Tamkang University Press.
- Inayatullah, S. (2018). *Asia 2038: Ten disruptions that change everything*. Taipei: Tamkang University Press.
- Inglehart, R. (2008). Changing values among Western publics from 1970 to 2006. *West European Politics*, 31(1-2), 130-146.
- Inglehart, R., & Baker, W. E. (2000). Modernization, cultural change, and the persistence of traditional values. *American Sociological Review*, 65(1), 19-51.
- Jones, P., Trier, C. J., & Richards, J. P. (2008). Embedding education for sustainable development in higher education: A case study examining common challenges and opportunities for undergraduate programmes. *International Journal of Educational Research*, 47, 341-351.
- Kelly, P. (2006). Learning for sustainable futures: One intervention. *Journal of Futures Studies*, 10(3), 1-14.
- Kelly, P. (2010). Engineering, a civilizing influence? *Futures*, 42, 1110-1118.
- Liu, S. C. (2019). Genetically modified food for the future: examining university students' expressions of futures thinking. *International Journal of Science Education*. doi:10.1080/09500693.2019.1585995
- Liu, S. C., & Lin, H. S. (2016). Envisioning preferred environmental futures: exploring relation-

- ships between future-related views and environmental attitudes. *Environmental Education Research*, 24(1), 80-96.
- Lowe, I. (2008). Shaping a sustainable future-an outline of the transition. *Civil Engineering and Environmental Systems*, 25(4), 247-254.
- Markley, O. W., & Harman, W. W. (1982). *Changing images of man*. Oxford: Pergamon Press.
- McNamara, K. H. (2010). Fostering sustainability in higher education: a mixed-methods study of transformative leadership and change strategies. *Environmental Practice*, 12(1), 48-58.
- Novy, M., Smith, M. L., & Katrnak, T. (2017). Inglehart's scarcity hypothesis revisited: Is postmaterialism a macro- or micro-level phenomenon around the world? *International Sociology*, 32(6), 683-706.
- Ojala, M. (2012). Hope and climate change: the importance of hope for environment engagement among young people. *Environmental Education Research*, 18(5), 625-642.
- Polak, F. (1973) *The image of the future* (E. Boulding, trans. & abr.) San Francisco: Jossey-Bass. (Original Dutch edition, 1955).
- Sterling, S. (2001). *Sustainable education: Revisioning, learning and change*. Totnes, UK: Green Books.
- Strife, S. J. (2011). Children's environmental concerns: Expressing ecophobia. *Journal of Environmental Education*, 43(1), 37-54.
- Taber, K. (2018). The use of Cronbach's Alpha when developing and reporting research instruments in science education. *Research in Science and Education*, 48(6), 1273-1296.
- Tibbs, H. (2011). Changing cultural values and the transition to sustainability. *Journal of Futures Studies*, 15(3), 13-32.
- Welzel, C., & Inglehart, R. (2010). Values, agency, and well-being: A human development model. *Social Indicators Research*, 97(1), 43-63.
- World Values Study (2016). WVS Wave 6 Dataset. Available at: [www.worldvaluessurvey.org/](http://www.worldvaluessurvey.org/)

# You Never Know How the Past Will Turn Out

Timothy Morton  
Rice University  
USA

**Keywords:** Designing Futures, Object Oriented Ontology, Temporality.

Anything at all is a designed thing. To be a thing is to have been designed: there is no such thing as formless matter—this too is an anthropomorphically scaled (and anthropocentrically scaled) illusion. What is often called Nature is simply nonhuman designed things. A thing—anything at all: a piece of topaz, a thought about a piece of topaz, a flaw in a piece of topaz, a geode full of topaz crystals—is like a train station. In this train station, past and future are trains that slide past one another without touching. The relative motion between past and future is what is mistakenly called “present,” erroneously conceived as an atomic point of whatever size (one nanosecond, a million years). (I will demonstrate this is in more detail in the essay.) The particular design of the train station itself is called temporality and anything at all has its own specific temporality. These temporalities are not necessarily anthropomorphically scaled, to put it mildly: most of them aren’t.

Every entity whatsoever — a mathematical equation about the refractive index of a piece of topaz, for instance — thus opens up a very specific kind of future, and the universe is simply a non-totalizable set of temporality structures. No one vantage point on this design universe can possibly be the perfect one, because by definition this vantage point, if real, is also a specific temporality structure.

This puts a burden on human design, because what design designs directly *are* futures, not simply things that point at a certain future. We now live in a time where agricultural-scaled anthropocentric designs are revealing their flaws: they cause global warming and mass extinction. We need to design some new things because we need some new temporalities, if only to think outside the narrow grey temporality pipe of Neolithic agricultural logistics.

We need them, and we can have them. Let me show you how.

Why do things have different temporality structures? It is in fact much better to say that they *are* different temporality structures. Why? Time is not a box in which things happen. The concept of time as a box is simply an anthropocentric construct. Because we elevate the human above everything else, we become blind to other perspectives, and this results in the objectification of human temporality — taking it as a universal container. This human temporality is then further objectified as “time,” in other words, the *measurement* of time is confused with time as such. Many human problems result from this this objectification — not the least of which being the colonialist imposition of one time to rule them all, as a brief glance at the history of Greenwich Mean Time, the establishment of London as zero longitude in the nineteenth century, will readily demonstrate.

First, then, human temporalities, which are how we make plans, project a future, create and destroy a world, get from A to B, are isolated from the other temporalities with which they overlap. Think about how your brain — which isn’t strictly “you” — has its own sense of time, which doesn’t quite fit the 24-hour clock. Think about the “plans” of your stomach bacteria, let alone the best laid plans of mice to get the bits of cheese you left on the plate after supper. These entities have their own temporality structures, which I will now call *timezones*

for the sake of convenience. It's not strictly true that there is a human-only timezone. The human timezone is composed of and overlaps with a whole host of nonhuman timezones.

Then, as I briefly sketched, this fake anthropocentric temporality is measured using some regular, rhythmical procedure such as walking or counting the numbers on a clock or detecting the decay of a cesium atom. Anthropocentric time is further objectified and reified! Unlearning that procedure, at the best of times, now takes on a highly subversive quality. Scientism denigrates it as hippy-dippy subjectivism, for example. The underlying, rippling and flowing quality of timezones is taken as a superficial candy that coats with a human flavor the truly "objective" discourses of measurement. As control society ramps up its intensity — a predominantly automatic function of its operating conditions — insisting that time isn't what we take it to be is often considered more preposterous than the existence of a Parliamentary leader whose impulses are not immediately inclined towards neoliberal "reality." Added to which, the main exponent of not taking time at (clock-) face value, Martin Heidegger, misreads temporality as destiny and puts the Germans in charge of the purest most authentic version of it. So it's terribly easy to dismiss.

But Heidegger only does this on the basis of a failure of nerve concerning his very own theory. For his idea that (human) being is time to work, Heidegger has to make unfounded metaphysical claims about nonhumans, the infamous "lizard" and the "stone" that are either poor in world (lifeforms) or entirely lacking in world (a piece of crystal, say). *World* here is a shorthand for what I mean by *timezone*, not a nice symmetrical container of events, but the Slinky-like movement that is inherent to (human) being as such, which Heidegger calls *ecstatic* (*ek-stasis*, standing outside of oneself). Stuff (Heidegger calls it "tools" or "equipment") is oriented towards our timezones. But for this orientation to work, it has to be partially invisible, just functioning in the background like an operating system in a mobile phone. It is "withdrawn" from objectifying presence, you can't point to it directly. This functioning is already a little bit not in our control! The vast, encompassing and largely unconscious shadow of being can't just be an effect of our destiny projects, because it logically subtends them — in other words, and this is how Heidegger puts it, "language speaks man," and not the other way around. The idea that there is a "we" that has a "destiny" for instance is *discursively* produced, by which is meant not simply in words (that would be nominalism) but in a manifold of practices and projects and concepts. There is something nonhuman about being as such. In which case, we might turn out to be something else altogether, at any moment — which is how history can happen.

So we don't even need to go down to the level of object-oriented ontology (commonly abbreviated as OOO), which I always like to do, in order to find the nonhuman. But when we do factor in OOO, it gets even easier. OOO is a way of thinking about how things exist. Things exist in such a way that they don't depend on how they are accessed or used or thought about (or licked or designed with) in order to exist. How things exist, then, is as a kind of mystery that can't ever be completely fathomed. To be a thing is to have a weird mysterious depth. OOO insists that for the timezoning process to work, stuff has to be radically nothing to do with us in the first place. A hammer doesn't suddenly become one when we notice it—the hammer just happens ("hammers happen" would be a good t-shirt slogan), until it breaks, in which case it reveals its not-quite-hammerness to us. And this means that the hammer is radically withdrawn, not just from human direct presencing procedures, but from *anything at all*, including the hammer in question!

In order for there to be equipment there have to be things, and these things or beings or entities (pick your favorite word) don't depend on any kind of access to make them real. Any kind at all, such as breaking them into tiny pieces in a scientific analysis. The breakage process, however neat and orderly it seems, doesn't get at the thing. Heidegger himself gives a vivid example. He holds up a piece of chalk and says okay, let's try to find out what this is by breaking it into smaller pieces. So he breaks it in half. And then he holds up the two pieces and says right, well now we have

two problems where first we had one... All the journalistic talk of CERN scientists discovering “fundamental building blocks” is simply a confusing and often oppressive reification.

Let’s return to our piece of topaz. We left it alone in the first paragraph but I can assure you it’s still around somewhere. If time isn’t to be found anywhere but in its very being, where is it? Look at the appearance of the topaz: its color, shape, heft, sparkle, all its qualities. These qualities, this appearance literally *is* the past, the past of the topaz’s timezone. It’s quite elementary to note that a number of things have happened to it: the topaz was extracted by humans and machines, it was cut into a specific shape, it was ground and polished. The appearance of the topaz is nothing but a story about what happened to it such that it became what it is right now.

But now that we’re on the subject, what exactly *is* this topaz, right now? Is it a piece of jewelry? Whose? Whose next? Is it a landing pad for this irritating mosquito? Is it a missile, albeit a rather expensive one, that I feel like chucking at the bin to see if I’m a good shot? Is it a great example of how things spray out time like a liquid in an essay by Timothy Morton?

It can be all of these things, because it isn’t any of these things. As soon as we look for the topaz like that, it slips away like the soap in the bath. This slipping-away quality *is the future*. *Is* the future, directly. Not “in” the future, but the future as such.

It’s not hard to see how this futurity is open. By *open* I mean something exactly like what is said when OOO says *withdrawn*. But perhaps *open* is a more...open word.

And it’s not hard to see how this picture leaves out the present, at least if we construe the present as a pointing-at or as an atomic point, that is, as a pointed-at-thing. Time isn’t the measurement of time, and this is one reason why we don’t want to include the present if we think it this way. But more fundamentally, things are not constantly present, and if our idea of *present* is a moment that is constantly present (however briefly), then we are thinking something that can’t exist, according to the logic I’ve all too briefly sketched out here. It is much better to think the present as an artifact of the sliding of past against future like trains at a junction. I call this sliding *nowness*. The *nowness* of the topaz jewel as it sparkles in your turning fingers...this isn’t the same as something that’s constantly there no matter what. That’s what isn’t available, whether we take that to be the jewel itself or some aspect of the jewel (its parts, say its atoms, or every single one of its aspects, in a sort of exploded view diagram).

Yet the past of the thing the past that is the appearance of the thing, is also unfathomable. This has to do with a paradox about contextualization, which is a very popular way of reducing things to “mere” effects of other things in the humanities and social sciences. Scientists break things into little bits, we contextualize them to death. But the interesting thing about contextualism is that it tends to be secretly *afraid* of the implications of contextualizing.

Because...where do you draw the line? In other words, where do you *stop* contextualizing? Form is history, history is form. With one stroke we can dispense with the age old debate between formalism and contextualism. In a way both are talking about the same thing — it’s a false dichotomy! So that isn’t the problem. The problem is, to say it again, how and why can contextualization stop? We stopped at the mine and the human miner. But the topaz also exists in the twenty-first century as a function of various economic factors such as capitalism, trade agreements, the economics of jewelry, “consumer demand” and so on. And the reason for *those* are a host of other factors which is why we could write a whole book about this one piece of topaz and not be done with it. Such accounts are often way too neat, as in the movie *The Red Violin*, which tracks the picaresque adventures of one of those instruments as it passes from human hand to human hand. At some point the contextualization machine will run out of steam — someone will just choose to stop at some arbitrary point, or temporality constraints will get in the way — I’d love to write a more complete topaz history, but breakfast got in the way, or tenure review, or my own concepts about what contexts are more relevant.

As Derrida pointed out, there is no outside-text — there is no context that finally grounds the thing, to which it can be reduced once and for all, because each context is an aspect of the thing's form, its appearance. We think we may be reaching a grounding limit: what a relief! This piece of topaz is really just “about” capitalism, or the jeweler who cut it, or the buyer who wears it, or... But we really reaching a limit as to our tolerance of the lack of a metaphysics of presence. We reach a point at which we say, this context is special, it's outside the other ones, outside the thing, so we can reduce the thing to it. In an OOO world we need something like a metaphysical immunosuppressant to prevent this from happening, because when it does, that's where the violence occurs.

The future is an abyss and the past is an abyss. The topaz opens up abyssal vortices of past and future. Potentially infinitely long trains cross at the junction, the timezone of the piece of topaz. But, as Wittgenstein said, *Explanations come to an end somewhere*, by which he means what I mean when I say that the contextualization machine stops at some point. There will always be a gap between the actual train and the potentially infinite train.

Since the past always forms a non-totalizable set of contextual horizons, without closure, center or edge, it is open too. What we have here is just this exact piece of topaz with just this exact appearance. It's not a sponge cake. But we won't be able to point directly at its determinacy. The past has its own futurity — there is a radical gap between what it is (potentially infinite contextualization) and how it appears (inevitably limited contextualization). Another way of saying the same thing is to say that every part of the topaz — and according to this our one little jewel *might* have (uncheckably) infinity parts — is a nowness junction, a timezone.

Which means that fatalism is wrong, karma is open, and you're not directly responsible for or are you inevitably chained to your horrible lot in life — it can be redirected, redesigned, reformed. There is wiggle room.

As Bob Dylan wrote, *You never know how the past will turn out*.

## Correspondence

Timothy Morton  
Rita Shea Guffey Professor of English  
Rice University  
USA  
E-mail: tbm2@rice.edu

# Design in the Future

**Paola Antonelli**  
**Museum of Modern Art**  
**USA**

**Cher Potter**  
**University of the Arts London**  
**Victoria and Albert Museum**  
**United Kingdom**

*Paola Antonelli is Senior Curator of the Department of Architecture and Design, as well as Director of Research and Development at The Museum of Modern Art (MoMA) in New York City.*

**Keywords:** Curation, Design Education, Restorative Design, Speculative Design.

**Cher Potter:** How do you see design and the future in relation to your own practice?

**Paola Antonelli:** Design *and* the future, or design *in* the future?

**CP:** That's interesting. Design *and* the future, I had said.

**PA:** Designers actually plan for the present and the immediate future. Sometimes they also plan for the remote future when they collaborate with scientists and do more speculative work. Built into the idea of design is an idea of a future, of a dynamic that moves forward. This is particularly the case with modern design, which concerns itself with 'progress'. As a curator of contemporary design, everything I do is built on the past, but for the purposes of the present and pushing towards the future.

**CP:** Are there avenues of future-oriented design that you're particularly interested in?

**PA:** Besides my curatorial practice, as a private individual I love science fiction. As you know, there are different types of science fictional futures — there's the gleaming, clean, translucent future; there's the dystopian future; there's the future that is a metaphor for present reality and history. I'm interested in all kinds of contemporary design about life and about the world. For the most part, I'm non-denominational! I don't have much patience for design that is just self-reflective, that is about form or is about exclusivity. I am interested in design that pushes the world forward.

**CP:** What do you think about the state of design education and futures?

**PA:** Ever since the Design Interactions course directed by Tony Dunne at the Royal College of Art, with Fiona Raby and others as teachers, there have been many programmes that have tried, in the way that they did, to frame and critique present and future social realities. I think that the most successful programmes are really based on plausibility rather than pie-in-the-sky ideas; the ones that deal with near futures, maybe ten years

from now. For me, the real difference between speculative design and a lot of science fiction is plausibility. *Design and the Elastic Mind*, a show I curated at MoMA eleven years ago, focused on designers' ability to grasp momentous changes in technology, science and society, and convert these into the objects and systems we use — and will use in the future. I argued that almost everything I was showing, with a few exceptions that were very clearly marked, was plausible.

**CP:** Do you think it's important that there be an aspect of problem solving to design?

**PA:** It's funny you bring that up. About three years ago, together with Kevin Slavin and Neri Oxman, I ran a programme at the MIT Media Lab in the summer time that was called 'Knotty Objects'. It began with a talk by Raby and Dunne and ended with an Oxford-style debate between Jamer Hunt, who ran Transdisciplinary Design at The New School, and Ahmed Ansari, a member of the Decolonising Design Collective, and a founder of the Architecture Design Research Lab in Karachi. The issue of real-world problem-solving and speculative design was the subject of a heated discussion! While I agree that unfounded far-futures speculation may not solve immediate problems, an important role for designers when working with scientists, for example, can be to provide far-reaching possibilities, inspiration for new directions in their practice and thinking.

**CP:** Looking forwards ourselves, could you talk a bit about the themes of your XXII Triennale di Milano exhibition<sup>1</sup> *Broken Nature: Design Takes on Human Survival*?

**PA:** It invites designers to embrace the idea of 'restorative design'. This is a concept in landscape design that is usually associated with ecological restoration, replenishing soils and so forth. My colleagues and I use the term 'restorative' to refer to a process by which design can restore itself — after exploiting resources, depleting the Earth, creating terrible imbalances — it has to take stock and build a new baseline, before it goes on to provide for pleasure and sensuality (Figures 1–4).



Figures 1–4. (Clockwise starting from top left): *Designs for an Overpopulated Planet: Foragers* by Anthony Dunne and Fiona Raby, 2009 © La Triennale di Milano | *Capsula Mundi*, designed by Anna Citelli and Raoul Bretzel, 2009 © Francesco D’Angelo | *The Great Animal Orchestra* by Bernie Krause, United Visual Artists, 2016 © Luc Boegly | *La Llaretta #0308-2B31* (3,000+ years old; Atacama Desert, Chile) by Rachel Sussman, 2008 © Rachel Sussman

I think we have severed some of the threads that connected us to nature — by ‘nature’, I don’t mean only oceans and plants but also other human beings, social constructs, microbiomes and so forth — and we have to try and repair them. Humans need to pay reparations (a purposefully contentious word with its links to righting the wrongs of slavery in America) to nature. We have enslaved nature, and even though it’s not the same as enslaving a whole group of human beings, we should use the terrible experience of the past to develop new viewpoints.

We would like people to leave the exhibition with, first, a sense of what they can do in their lives to move towards this idea of restorative design — simple and practical things, changing habits, choosing more sustainable alternatives; second, I would like to give the Triennale’s audiences a sense of the fact that we live in complex systems, and that we have to learn the pressure points we can use to have a positive impact on this amazing organism that is the Earth; and third, I would like to give them a sense of long time, beyond two or three generations, centuries, millennia. The exhibition starts by highlighting the changes humanity and Earth have gone through, ponders the

remote past and the remote future, moves into a section examining ways to restore natural and social systems, and then into a room devoted to restorative attitudes in everyday life; from there, we take flight again to study complexity, and we end with empathy — for other humans, species, things.

**CP:** As a final point, do you see any stumbling blocks regarding design in — and of — the future?

**PA:** A problem with design education today is not the existing models or ideas, but the cost. If students have to pay enormous amounts of money for their education, they will be forced to go directly into commercial practice in order to pay their debts. This stops the designer from exploring his or her imagination, from finding his or her own creative approaches to the problems of the world.

Moreover, educating the people that hire designers is as important as educating designers themselves. Perhaps one of Fiona Raby and Tony Dunne's most powerful impacts on the design industry was that they taught industry people how to *use* speculative designers' ideas. Dominic Wilcox for instance has designed very playful breakfast accessories for Kellogg's to encourage children to eat in the mornings in his *Re-imagining Breakfast* series, which includes a tummy-rumble amplifier and a breakfast-serving drone.

It is really important for young designers to know that there are so many different ways to be a designer.

## Correspondence

Paola Antonelli  
MoMA  
USA  
<http://www.moma.org>

Cher Potter  
University of the Arts London  
Victoria and Albert Museum  
UK  
E-mail: [c.j.potter@arts.ac.uk](mailto:c.j.potter@arts.ac.uk)

## Notes

1. 1 March – 1 September 2019.

This text is an edited transcript of a conversation that took place on 15 November 2018.

# Making Things Physical

**Maja Kuzmanovic**  
FoAM  
Belgium

**Tina Auer**  
Time's Up  
Austria

**Nik Gaffney**  
FoAM  
Belgium

**Tim Boykett**  
Time's Up  
Austria

---

## Abstract

*In this paper we present a cross-section of FoAM and Time's Up's work with physical narratives (PNs), which draws upon experiential futures and experience design. We introduce PNs as explorable, multisensory spaces before discussing the importance of enabling social interaction. We describe a series of creative experiments with PNs to illustrate our approach to futures in an artistic context, including installations, exhibitions and festivals. The design of the PNs involve a range of futures techniques (such as scenario development or design fiction) to invite participatory explorations of the "visionary present". We do not intend to provide a critical analysis of the design process, methods or implications; rather, the article offers a reflection on our motivations and insights. As an invitation to further dialogue between transdisciplinary fields, we conclude with a call for futurecrafting at a human scale.*

**Keywords:** Experiential Futures, Immersion, Futurecrafting, Physical Narratives.

---

## Introduction

Physical narrative (PN) can be described as a theatre without actors, where spectators become engaged participants, playfully discovering futures by experiencing physical spaces, objects and media. A PN is an explorable world. An open scenario rather than a singular story. PNs take the form of immersive installations where entangled fragments of scenarios can be experienced through all the senses as a self-contained, aesthetically coherent reality. Direct experience of scenarios, when presented as physical prototypes, entangle the participants with alternatives to the status quo, and suggests that futures can be proactively influenced by those who engage with them (Candy, 2010; Dator, 2009; Inayatullah, 2005; Kuzmanovic & Gaffney, 2017b; Ramos, 2005).

As there are no human guides in a PN, visitors gather meaning and interpret situations in a similar way as they would in unfamiliar environments. They are invited to observe, investigate and discuss what it might be like to be a part of a possible future, in physical situations that can be freely explored. Reading a foresight report or watching design fiction videos assumes a distance between the scenario and the reader or viewer. In physical narratives, visitors become a part of the scenario, surrounded by it as if they were in a parallel world. The level (or depth) of immersion is important, allowing visitors to investigate the scenario using all their sensory, somatic, intuitive and cerebral faculties (Floyd, Burns, & Ramos, 2008; Varela, Thompson, & Rosch, 1991). Such immersive experiences can be intense and disorienting, especially with near future scenarios<sup>1</sup> (Superflux, 2017). The future can feel quite up-close-and-personal, eliciting strong emotional responses, or a desire to understand repercussions the experience may have for the visitors' own lives (Slaughter, 2008). Incorporating social spaces within PNs to decompress and share experiences is crucial for their critical assimilation. The visitors can exchange insights and extrapolate to their own aspirations and projections, thereby developing their capacity for (ambient) foresight (Candy, 2010) and contributing to the spread of futures literacy (Miller, 2011, 2015).

## Elements of Experiential Explorations

With physical narratives we design speculative situations and scenarios (Curry & Schultz, 2009) as tangible environments. PNs generally incorporate three key aspects in their design: playful exploration, multisensory experience and social interaction (Time's Up & FoAM, 2013). The following paragraphs provide a brief overview of our rationale and several examples from our practice.

## Explorable Spaces

In a PN, scenarios become ambient narratives, with no predefined beginnings or endings, and no linear progression from one story element to another. As the scenarios (future, present or parallel) are scattered across the space in hints and fragments, it is impossible to experience a PN as a clearcut, singular future: there are many possible stories hidden within, requiring the participant to be aware and active (Dator, 2009). Characters and storylines are implicitly discovered, rather than explicitly described. Like a good horror film, PNs affect the viewer just as much by what is left unseen as by what is presented (Nakata, 1998). They invite the visitors to actively uncover, interpret and co-create a range of possible scenarios; to weave the story-fragments together from physical artefacts, media snippets and dispersed segments of the characters' stories (Candy, 2010; Raford, 2012). They create meaning on-the-fly, akin to free play (Kane, 2004), where the making and breaking of rules and hypotheses about the world simultaneously creates the world itself.



Figure 1. Borrowed Scenery (2012)

In the PN *Borrowed Scenery* (FoAM, 2012) (Figure 1), visitors can unearth scenarios where plant cultures and human societies have become deeply intertwined to the point of becoming indistinguishable (Kuzmanovic & Gaffney, 2017a). The installation (presented in Belgium and Austria) is built around a *Patabotanical lab* inhabited by elusive characters, known only by their physical traces: experiments-in-progress, field-notes and prototypes, a collection of books, plants, disembodied scents and mysterious artefacts. Everything in the atemporal ambience of this verdant, biomorphic, technologically advanced world reflects an element of one or more scenarios. Traces of a plausible near future co-exist alongside evocative speculative fictions (Gaffney & Howse, 2013). A map of the city as edible landscape; instructions for a botanically infused psychogeographic drift. Translation of a vegetal communiqué concerning human extinction; archaic and contemporary devices for human-plant communication (Kuzmanovic & Gaffney, 2008; Essaïdi, 2014). From physical juxtapositions and connections between such artefacts, visitors tend to extrapolate their own versions of the initial scenarios. While some ideas can be directly related to existing initiatives, others delve further into the realm of science fiction (or speculative fact). The PN draws upon the visitors' personal experiences, with the intent to develop their relationships with plants and find ways of coexisting in the Anthropocene (Morton, 2016).



Figure 2. Stored in a Bank Vault (2011)

In *Stored in a Bank Vault* (Time's Up, 2011) (Figure 2), visitors take on the role of a detective, stumbling into the underground lair of a group about to rob a nearby bank vault. As visitors inspect the basement, they uncover various aspects of the story — in hacked computers, tapped surveillance cameras, architectural plans, sedatives, by overhearing a character's phone conversation behind a locked door, or chancing on a plan of attack. Dedicated investigators discover that the heist may not be just about cash, but some enigmatic seeds. They may find a trail of the group's previous exploits that reveal deeper layers of motivation. Like in a good thriller, this leads to surprises and unexpected plot-twists, seducing the visitors to delve deeper into the story.

## Multisensory Spaces

PNs are interactive environments in which fragments of scenarios are transformed into physical spaces, objects and tangible media. When people explore possible futures by touching, standing on, handling or smelling speculative artefacts, they rely on their mental, emotional, as well as somatic faculties. Engaging all senses allows for embodied, multimodal learning and stimulates imagination (Floyd et al., 2008). The immersive, interactive nature of PNs invites visitors to “fill in the blanks” between scenario fragments (Miller, 2015). As in the adage “I hear and I forget, I see and I remember, I do and I understand”, in PNs the visitors can relate to abstract concepts as experiential phenomena, which makes them more approachable and easier to understand. Rather than read and analyse, or watch and absorb, they inhabit the scenario, learning by doing (Ramos, 2005).



Figure 3. Lucid Peninsula (2014)

In *Lucid Peninsula* (Time's Up, 2014) (Figure 3), visitors find themselves in a hotel room, in a future where pollution and environmental degradation have led to peculiar developments in medical and consciousness technologies. An airtight window is fitted with the *OrganoClean* air purification system, the room breathing mechanically, as the air bubbles past plants growing in oversized test tubes. The buzzing of a detox shower can be heard through the locked bathroom door. Clothing items are tagged as having been decontaminated. The bed is flanked with a *General Infection Negation* blood cleansing device and a *DreamNet* system for “sharing dreams with friends and colleagues.” Upon entering the room, visitors are absorbed in the hypnotic breathing rhythms; many lie on the bed with their eyes closed, while others pensively investigate the copper-tubed breathing apparatus and brass window viewer, showing an overlay rendering of the outside world.

Similarly meditative, *Stillness* (FoAM, 2016; Gaffney, Morton, & Kuzmanovic, 2016) was an exhibition and immersive experience designed to slow down the pace of visitors' hectic lives. A parallel present (or near future) where slowness, contemplation and idling are not seen as luxuries but rather as necessities to survive in a world of fragmented interconnectivity, distraction, displacement, and other forms of contemporary malaise (Tsing, 2015). Filmic sequences of photographs are laid out as parcours through the space, occasionally overlaid with sound and scent. Fragments of the ambient narrative could be uncovered in objects, images, food, drinks and texts found in improbable places, hiding under vegetation or scattered across the ceiling. The layout of the space and furnishings suggested a particular flow of experience, gradually decelerating and enveloping the visitors in stillness of sound, scent and light.



Figure 4. Stillness (2016)

## Social Spaces

Physical narratives provide a shared experience of speculative scenarios. Before and after experiencing a PN, the visitors cross a “threshold” between their present and a possible future (Huizinga, 1970; Turner, 1991). A period of “compression” and “decompression” can help relate these experiences more closely to people’s lives. Like those who have shared an intense situation or peak experience (e.g. a natural disaster, mountain climbing or psychedelics) visitors often feel a need to spend time together sharing, comparing and making sense of their PN exploits. They may re-enter the PN after discussing it, looking for details which others alerted them to, things they may not have noticed previously. Social interaction can enrich the story and the experience for all involved (Inayatullah, 2005). This can be facilitated by surrounding the PN with familiar social situations, such as a lounge, a bar, or a waiting room. It can be as simple as including a pair of period chairs on a carpet in *Unattended Luggage* (Time’s Up, 2012), where the visitors would sit and closely examine elements of the story together. A more extensive approach was the bar of the *Sensory Circus* (Time’s Up, 2004) or the *SubCity* environment for *BodySPIN* (Time’s Up, 2001), where visitors reclined and quietly conversed over drinks. They were surrounded by small screens and other “windows” into the PN, keeping them connected to the actions taking place in the installation, only a few meters away. While these spaces are thematically linked to the PN scenarios, they are obviously in the here-and-now.



Figure 5. Unattended Luggage (2012)

In *Godsheide Futures* (FoAM, 2015), where we looked at possible futures for shared public spaces in a Belgian residential neighbourhood, fragments of scenarios were experienced as part of a reception. While visitors engaged in the usual mingling and networking, the scenarios began to enter their conversations via finger-foods and aperitifs. Translating scenarios into “edible futures” (FoAM, 2014) created an informal atmosphere that encouraged conversation between policy makers, urban planners and the inhabitants. Over food and drinks, almost imperceptibly, the first commitments were made to bring some of the scenarios into reality. A year after the reception, the inhabitants have successfully repurposed a local church into a community-supported school and plans are underway to form a co-operative for more ambitious projects.



Figure 6. Godsheide Apero (2015)

By “holding space” (Corrigan, 2006) and informally engaging with the visitors, we do not leave people “hanging” after experiencing (sometimes disturbing) futures. If we are interested in experiential futures affecting thoughts and behaviours in the present (Ramos, 2005; Inayatullah, 2004) hosting the visitors’ conversations and reflection is as important as creating a compelling futures narrative. Such (strategic) conversation allows the experiential insights to echo in the visitor’s work and life, raising ambient awareness of possible future repercussions (Chermack, Lynham, & Ruona, 2001; Gidley, Fien, Smith, Thomsen, & Smith, 2009; Haraway, 2016). This implies moving away from consuming futures as entertaining speculative fiction and towards a more widespread futures literacy (Candy, 2010; Miller, 2011).

### Futurecrafting at a Human Scale

Working with physical narratives as a means to experience future scenarios has led us to understand the importance of working with futures at a human scale, connecting them to the mundane, personal, social aspects of everyday life (Calvin, 2009; Candy, 2010; Ryman et al., 2004). By diffusing fragments of futures in physical spaces, rather than spoon-feeding visitors a singular future vision, we aim to stimulate a sense of agency while experiencing the PN, as well as long after the experience has ended. Freedom to play with and interpret scenarios, also referred to as worldmaking (Vervoort, Bendor, Kelliher, Strik, & Helfgott, 2015), lets visitors uncover multiplicities of possible futures, and an ability to co-create them (Gidley et al., 2009). Social interaction within PNs can help focus our capacity to change things in the present. By collectively experiencing a “visionary present” (Ballard, 2001) people tend to be more open to cultivating preferred futures, futures that encourage wonder, hope and engagement (Montouri, 2011; Ogilvy, 2011). Away from monolithic dystopian visions and towards something more malleable and elastic,

from “an overly abstract concept lacking relevance” towards an “inspirational call to action with traction” (Ramos, 2005).

Physical narratives provide a structure within which we can approach futures with all the rich detail of corporeal reality, futures that are tangible and explicable, futures that emerge somewhere between scenario-planning and design (Selin, Kimbell, Ramirez, & Bhatti, 2015). Where visitors are encouraged to think about future possibilities and invited to deepen their involvement (Ogilvy, 2011; Kelleher, 2005). The exploration of futures through physical experience could be seen as an entry point into an expanding futures literacy. Where experiencing futures creates space to reflect and act today.

## Correspondence

Maja Kuzmanovic and Nik Gaffney  
FoAM  
Belgium  
E-mail: info@fo.am

Tina Auer and Tim Boykett  
Time’s Up  
Austria  
E-mail: info@timesup.org

## Notes

1. Similar to the “uncanny valley” phenomenon in robotics and computer graphics: the more familiar the environment, the more the visitors may notice the “strangeness” of the scenarios.

## References

- Ballard, J. G. (2001). *The complete short stories*. London: Flamingo.
- Calvin, R. (2009). Mundane SF 101. *SFRA Review*, 289, 13-16. <https://sfra.wildapricot.org/resources/sfra-review/289.pdf>
- Candy, S. (2010). *The futures of everyday life: Politics and the design of experiential scenarios* (PhD Dissertation). Department of Political Science, University of Hawaii at Manoa. doi:10.13140/RG.2.1.1840.0248
- Chermack, T., Lynham, S. A., & Ruona, W. E. A. (2001). A review of scenario planning literature. *Futures Research Quarterly*, 17(2), 7-31.
- Corrigan, C. (2006). *The Tao of holding space: 81 short chapters on facilitating Open Space*. [https://ia800306.us.archive.org/32/items/TheTaoOfHoldingSpace/Tao\\_of\\_holding\\_space.pdf](https://ia800306.us.archive.org/32/items/TheTaoOfHoldingSpace/Tao_of_holding_space.pdf)
- Curry, A., & Schultz, W. (2009). Roads less travelled: different methods, different futures. *Journal of Futures Studies*, 13, 35-60. <http://www.jfs.tku.edu.tw/13-4/AE03.pdf>
- Dator, J. (2009). Alternative futures at the Manoa School. *Journal of Futures Studies*, 14, 1-18. Retrieved from <http://www.jfs.tku.edu.tw/14-2/A01>
- Essaïdi, J. (2014). *Living Network*. <http://jalilaessaïdi.com/living-network/>
- Floyd, J., Burns, A., & Ramos, J. (2008). A challenging conversation on integral futures: Embodied foresight and dialogues. *Journal of Futures Studies*, 13, 69–86. <http://www.jfs.tku.edu.tw/13-2/E01.pdf>
- FoAM. (2012). *Borrowed scenery: Cultivating an alternate reality*. <http://fo.am/borrowed-scenery/>
- FoAM. (2014). *Food futures*. [http://lib.fo.am/future\\_fabulators/food\\_futures](http://lib.fo.am/future_fabulators/food_futures)

- FoAM. (2015). *Godsheide futures*. [http://lib.fo.am/future\\_fabulators/godsheide\\_futures](http://lib.fo.am/future_fabulators/godsheide_futures)
- FoAM. (2016). *Stillness*. <http://fo.am/stillness/>
- Gaffney, N., Morton, T., & Kuzmanovic, M. (2016). *Stillness*. Ghent, Belgium: MER. Paper Kunsthalte.
- Gaffney, N., & Howse, M. (2013). Approaching the inexplicable. In Time's Up & FoAM (Eds.), *PARN: Physical and alternate reality narratives*. Linz, Austria: Time's Up. <https://medium.com/aperiodic-mesmerism/approaching-the-inexplicable-7e1793b2a588>
- Gidley, J. M., Fien, J., Smith, J., Thomsen, D. C., & Smith, T. F. (2009). Participatory futures methods: Towards adaptability and resilience in climate-vulnerable communities. *Environmental Policy and Governance*, 19(6), 427-440. doi:10.1002/eet.524
- Haraway, D. J. (2016). *Staying with the trouble: Making kin in the Chthulucene*. Durham, NC:: Duke University Press.
- Huizinga, J. (1970). *Homo ludens: A study of the play element in culture*. London: Maurice Temple Smith Ltd.
- Inayatullah, S. (2004). *The causal layered analysis (CLA) reader: Theory and case studies of an integrative and transformative methodology*. Taipei: Tamkang University.
- Inayatullah, S. (2005). Anticipatory action learning: Theory and practice. *Futures*, 38(6), 656-666. doi:10.1016/j.futures.2005.10.003
- Kane, P. (2004). *The play ethic: A manifesto for a different way of living*. London: Macmillan.
- Kelleher, A. (2005). A personal philosophy of anticipatory action learning. *Journal of Futures Studies*, 10(1), 85-90. Retrieved from <http://www.jfs.tku.edu.tw/10.1.85.pdf>
- Kuzmanovic, M., & Gaffney, N. (2017a). *GroWorld. Experiments in vegetal culture*. <https://medium.com/invironment/groworld-c777f5c09c4f>
- Kuzmanovic, M., & Gaffney, N. (2017b). Enacting futures in postnormal times. *Futures*, 86, 107-117. doi:10.1016/j.futures.2016.05.007
- Kuzmanovic, M., & Gaffney, N. (2008). Cursory speculations on HPI. *ISEA 2008*, Singapore. [http://fo.am/cursory\\_speculations\\_on\\_hpi/](http://fo.am/cursory_speculations_on_hpi/)
- Montouri, A. (2011). Beyond postnormal times: The future of creativity and the creativity of the future. *Futures*, 43(2), 221-227. doi:10.1016/j.futures.2010.10.013
- Miller, R. (2011, October 1). Opinion: Futures Literacy — Embracing Complexity and Using the Future. *Ethos*, 10. Retrieved from <https://www.csc.gov.sg/articles/opinion-futures-literacy-embracing-complexity-and-using-the-future>.
- Miller, R. (2015). Learning, the future, and complexity: An essay on the emergence of futures literacy. *European Journal of Education*, 50(4), 513-523. doi:10.1111/ejed.12157
- Morton, T. (2016). *Dark ecology: For a logic of future coexistence*. New York: Columbia University Press.
- Nakata, H. (Director). (1998). *Ringu*. Japan: Basara Pictures.
- Ogilvy, J. (2011). Facing the fold: from the eclipse of Utopia to the restoration of hope. *Foresight*, 13(4), 7-23. doi:10.1108/14636681111153931
- Raford, N. (2012). From design fiction to experiential futures. In A. Curry (Ed.), *The future of futures* (pp. 34-38). Houston, TX: Association of Professional Futurists.
- Ramos, J. M. (2005). Action research as foresight methodology. In R.A. Slaughter, S. Inayatullah, & J. M. Ramos (Eds.), *The Knowledge Base of Futures Studies*. Indooroopilly, Australia: Foresight International.
- Ryman, G. et al. (2004, July 4) *The Mundane Manifesto*. Retrieved from <https://sfgenics.wordpress.com/2013/07/04/geoff-ryman-et-al-the-mundane-manifesto/>
- Selin, C., Kimbell, L., Ramirez, R., & Bhatti, Y. (2015). Scenarios and design: Scoping the dialogue space. *Futures*, 74, 4-17. doi:10.1016/j.futures.2015.06.002
- Slaughter, R. A. (2008). Integral Futures Methodologies. *Futures*, 40(2), 103-108. doi:10.1016/j.fu-

tures.2007.11.011

- Superflux. (2017). *Mitigation of Shock*. <http://www.cccb.org/en/multimedia/videos/interview-to-superflux-studio/228471>
- Time's Up. (2012). *Unattended Luggage*. <http://timesup.org/unattendedluggage>
- Time's Up. (2004). *Sensory Circus*. <http://timesup.org/sensorycircus>
- Time's Up. (2001). *BodySPIN*. <http://timesup.org/content/body-spin>
- Time's Up. (2011). *Stored in a Bank Vault*. <http://timesup.org/stored-bank-vault>
- Time's Up. (2014). *Lucid Peninsula*. <http://timesup.org/LucidDreaming>
- Time's Up & FoAM (Eds.). (2013). *PARN: Physical and alternate reality narratives*. Linz, Austria: Time's Up.
- Tsing, A. L. (2015). *The mushroom at the end of the world: On the possibility of life in capitalist ruins*. Princeton, NJ: Princeton University Press.
- Turner, V. W. (1991). *The ritual process: Structure and anti-structure*. Ithaca, NY: Cornell University Press.
- Varela, F. J., Thompson, E., & Rosch, E. (1991). *The embodied mind: Cognitive science and human experience*. Cambridge, MA: MIT Press.
- Vervoort, J. M., Bendor, R., Kelliher, A., Strik, O., & Helfgott, A. E. R. (2015) Scenarios and the art of worldmaking. *Futures*, 74, 62-70. doi:10.1016/j.futures.2015.08.009



# Napkin Futures: Fragments of Future Worlds

Nik Baerten  
Pantopicon  
Belgium

---

## Abstract

*Every day archaeologists dig up fragments of past worlds and cultures. Through these they try to construct a bigger picture of life in times bygone. The incompleteness of their findings raises questions and catalyses hypotheses. The fragments project the beholder beyond the present timeframe and engage him/her in active reflection on the bigger picture potentially uniting or complementing the fragments in another timeframe. What if we could create a similar context of engagement around life in the future? In ‘napkin futures’<sup>1</sup>, micro-narratives sketched on paper napkins appear like excerpts from stories and happenings in the future. As if ripped from their broader context, each fragment invites to be unravelled into a bigger narrative. Both ultra-compact forms of design fiction and instruments of ‘preflection’, ‘napkin futures’ experiment with how a narrative fragment can be a powerful ‘agent évocateur’ and catalyst for debate with respect to futures.*

**Keywords:** Design Fiction, Experiential Futures, Storytelling.

---

## Origin

‘Napkin futures’ started as a side-project of the author to further explore, reflect upon and hold onto new ideas and speculations inspired by his work as a foresight and design practitioner. Gradually, the napkins developed from an instrument of personal use to an instrument for others to engage with new meanings arising from possible future worlds.

Each napkin features a rough sketch, generally accompanied by a small narrative, an excerpt from a seemingly larger story in which a future world is evoked.<sup>2</sup> Each story is in one way or another a rupture, a departure from today’s world as we know it, at odds with the current state or logic of things. The story’s estranging factor is a key enabler in luring people down the rabbit hole of their imagination.

The fragmentary nature of the napkin makes it clear that there is a larger narrative out there. As the reader takes in the image and the micro-narrative, he/she enters a process of hypothesis building, spurred by questions emerging from the apparent omissions. For example:

What does ‘airbanification’ mean (NF025)? Why does Italo Vishnu take it as his mission in life to dismantle old structures (NF019)? How would ‘hovereyes’ work (NF007)? What would a ‘Chief Spiritual Officer’ do in an organization (NF024)? What would have caused these things to emerge in our societies?

Thus the napkin futures can be considered catalysts for the imagination, ‘tools for thought’. It is worth noting however, that any depiction of the future is heavily shaped by — and thus reflective of — the lens through which we see and interpret reality today. Hence, the visions and questions raised by the napkins are likely to speak of and to the present as much as the future.



*Figure 1.* NF030 The Hendriksen Tree “Statistically speaking, the Hendriksen tree was genomically more human than plant. Deforestation of the area would hence be considered genocide. The Hendriksen case would be a turning point in history. Judge Chang could sense the sweet smell of fame in the air.”

## Minimum Viable Narrative

In foresight, the notion of using a ‘minimum viable narrative’ to package different future developments in a single plausible context, can be discerned for example in the use of storylines in scenario development or visioning. In the case of the napkin futures however, rather than using storytelling to describe and/or explain a possible future, the emphasis lies most of all on provoking and raising new questions. This positions the napkins in the realm of more speculative approaches to design (Dunne & Raby, 2013) and design fiction (Bleecker, 2009).

The napkin futures are equally related to Marshall McLuhan’s notion of ‘probes’; word plays and bold perceptions used as exploratory tools, through provocation, raising awareness and questions. McLuhan describes them as follows (1967): “I tend to use phrases, I tend to use

observations that tease people, that squeeze them, that push at them, that disturb them, because I am really exploring situations. I am not trying to deliver some complete set of observations about anything.”



Figure 2. NF027 Memory craftsmen “She knew exactly what she wanted him to buy for her: a full-sensory set of memories crafted by Sartorelli. It would cost him a small fortune but provide her a lifetime of pleasure.”

## From Verse to Multiverse

The fragmentary and hence ambiguous nature of each napkin opens the door to a variety of interpretations. Each person unravels the fragment into a broader story in a different way, focusing on different elements and interpreting their combined meaning differently.

The multiple images or notions in one napkin challenge people to build hypotheses regarding a plausible relationship between them. New meanings emerge from the semiotic in-between space thus created. New or previously hidden ideas and ways of reading reality emerge from the cracks of the broken present.

This process is reminiscent of Sergei Eisenstein’s interpretation of montage as generating new meaning by juxtaposing two images. He noted that “two film pieces of any kind, placed together, inevitably combine into a new concept, a new quality, arising out of that juxtaposition” (Eisenstein, 1957, p.4, original emphasis) and continues by saying that this is the case for any situation in which

two facts, two phenomena or two objects are juxtaposed.

Furthermore, as audiences engaged with the napkins<sup>3</sup>, people noted that they could see some napkins as describing different situations from the same future world. Like terracotta shards found on an archaeological site, people would attempt to reimagine what the complete vase looked like. This way of narrative building on the basis of fragments bears resemblance to the way in which writers such as Marcel Proust or W.G. Sebald compiled elaborate stories out of bits and pieces.

## Of Words and Worlds

One way to evoke the future in storytelling is through the introduction of new, fictional terminology. It is a key strategy also to attain compactness, something also noted by Bruce Sterling in his reflections on the napkin futures when he wrote:

“I’ve been wondering what the ‘atomic element’ of a design fiction is. What’s the least thing one can do that constitutes a design fiction? A napkin sketch must be pretty close — but if it needs an explanation in order to make its point, then maybe it’s a \*word\* that’s the smallest possible element — a neologism.” (Sterling, 2013)

Either through the familiarity of their constituent parts or their context, neologisms can suggest new concepts or meanings. The use of words and language to evoke the future is an antidote to our infatuation with rendering futures tangible through mostly visual means (Baerten, 2016). In this spirit, inspired by the work of Polish science-fiction writer Stanislaw Lem (1976), *NF036 The Neological Institute*, explores the power of language itself. Its narrative suggests how words are able to generate new worlds. This napkin was recently elaborated in a workshop/performance bearing the same title<sup>4</sup>.

Also, when notions or concepts are brought together in a story in ways that defy past and present logics, it is a powerful trigger to unshackle readers from the present and allow them to see things in a different light, inspire new possibilities. Narrative — as a instrument of knowledge and sensemaking — is unique in its capability to bring thesis and antithesis together in a new synthesis, giving birth to new meaning.



*Figure 3.* NF036 The Neological Institute “We are gathered here today to commemorate Stanislaw, the founding father of our house, The Neological Institute. We are here to perpetuate his legacy, the deep belief that new vocabularies and linguistics give birth to new times. Like the imagination precedes the image, new words breed new logics, language brings forth new futures. This is why we are here: to celebrate our role in the continuous becoming of our world.”

## **Last But Not Least**

Walter Ong showed how storytelling, narrative is a way of knowing (Ong, 1982). For author as well as audience, the creation and digestion of design fictions such as the napkin futures feeds into a philosophy of gymnastics for the mind. Once an alternative reality has been uncovered, not only the presented alternative as such, yet the very existence of multiple alternatives can no longer be ‘unthought’. It is an escape route from dichotomy-based thinking, taking us beyond our tendency to exchange one model or logic for the world for another, to a way of thinking, knowing and acting based on diversity; which is not coincidentally one of the key points where foresight and design meet.

## Correspondence

Nik Baerten  
Pantopicon  
Belgium  
E-mail: [nik@pantopicon.be](mailto:nik@pantopicon.be)

## Notes

1. See <http://napkinfutures.tumblr.com>
2. Sketch and text would not always originate simultaneously, hence some napkin futures only feature an image or text, some of which were combined at a later stage.
3. e.g. *Future Fictions* exhibition at Z33 Arts Centre in Hasselt, Belgium. See <http://www.z33.be/en/projects/future-fictions>
4. The workshop took place during the 50th anniversary conference of the Design Research Society, *Future-focused Thinking* in Brighton, UK, on June 30, 2016. The atmosphere of linguistic research and archival bureaucracy evoked in *NF036* was brought to life in a four-hour long experience shaped around an onboarding experience for new employees of the institute. Participants were initiated in the art and craft of *logogenesis*, *praxis*, *semiosis* and *constellography*. See <http://pantopicon.be/2016/07/06/the-neological-institute/>

## References

- Baerten, N. (2016). Beyond visualization: Experiencing the future. In P. van der Duin (Ed.), *Fore-sight in organizations: Methods and tools* (pp.223-237). New York: Routledge.
- Bleecker, J. (2009). Design fiction: A short essay on design, science, fact and fiction. *Near Future Laboratory*. Retrieved from <http://blog.nearfuturelaboratory.com/2009/03/17/design-fiction-a-short-essay-on-design-science-fact-and-fiction/>
- Dunne, A., & Raby, F. (2013). *Speculative everything: Design, fiction, and social dreaming*. Cambridge, MA: MIT Press.
- Eisenstein, S. (1957) *The film sense* (J. Leyda, Ed. & Trans.). New York: Meridian Books.
- Lem, S. (1976). *The futurological congress*. New York: Avon.
- McLuhan, M. (1967) Probe as a tease. In *This is Marshall McLuhan: The medium is the message* [Television program]. National Broadcasting Corporation. Video at <http://www.marshallmcluhanspeaks.com/understanding-me/1967-probe-as-a-tease/>
- Ong, W. J. (1982). *Orality and literacy: The technologizing of the word*. London: Methuen.
- Sterling, B. (2013, November 26). Design fiction: Napkin futures. *Wired*. Retrieved from <http://www.wired.com/2013/11/design-fiction-napkin-futures/>

# Change the Model

**Dan Hill**  
Vinnova  
Sweden

**Stuart Candy**  
Carnegie Mellon University  
USA

---

## Abstract

*Dan Hill is Director of Strategic Design at Vinnova, the Swedish government's innovation agency. He has previously held design leadership roles at Arup Digital Studio, Future Cities Catapult, Fabrica, Sitra, and the BBC.*

**Keywords:** Dark Matter, Design Fiction, Evaluation, Overton Window, Policymaking, Strategic Design.

---

**Stuart Candy:** How do you see your work in relation to design and futures?

**Dan Hill:** All design work is by definition to do with the future. In terms of the types of design that I do, there's three sort of ambits of design, and I imagine it like the futures cone, but... without the futures cone!

So in the pointy end there is interaction design, which is the touchpoint. How do I unlock a MoBike? Hold a phone over a QR code. (Figure 1)

Service design broadens that out slightly. That's the business model, how it operates, who maintains it, how the transaction works; do I pay by credit card or through Apple Pay; does the Apple Pay API talk to MoBike API? It's all to do with arranging touchpoints. It's still in the *matter* world a bit more, as there's physical things, it's just orchestrating those into something that feels coherent, ideally.

And then going a bit further again is strategic design, which is when we get more *dark matter-y*: What conditions do we need to put in place for that to thrive? Can we legally do this thing in this country? How does it relate to other services you might use in the city? That needs to be organised, or thought about at least.

So you've got interaction design, service design, strategic design, up and down this scale.

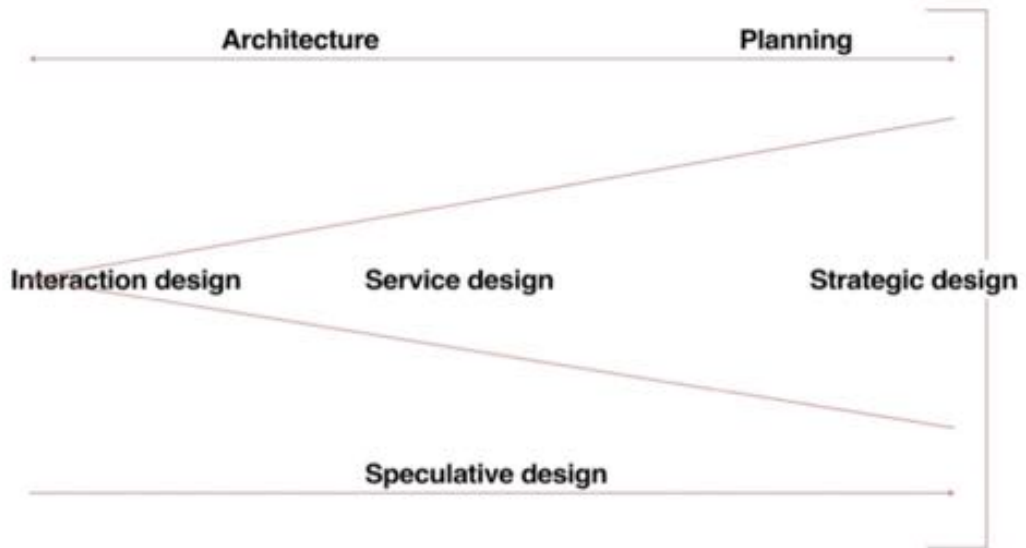

Figure 1. Scales of design. Diagram by Dan Hill

And then I think of speculative design, if we were to use that phrase, it's a time slider. So we could look at interaction design, if we're doing MoBike, and it's for right now, or maybe next year. But we could do a speculative design / interaction design piece about what's it going to be in five years' time. Maybe I'm paying with my glasses, or unlocking it with my shoes! But it's still about the touchpoint. We can do speculation about the service design layer and speculation about the strategic design layer — so, let's ratchet up the speculative design dial.

**SC:** So what's broadening out, if it's a cone diagram of something widening?

**DH:** It's trying to take into account both *matter* and *dark matter*. The dark matter being the organisational model, the legal model, or the political situation.

**SC:** It's more of the world.

**DH:** Yeah, that's maybe the simplest way of saying it. And the reason that's important to me is because working in cities, you're trying to make systems, and systems that change systems, one way or another. I don't think you do that at the interaction design scale stage much. You're just concentrating on the latency of the QR code reader and is that going to be fast enough communicating with the bike hardware. Those are really material concerns. Whereas the strategic design layer is really the systemic change possibility.

One thing I would say about this, almost the unspoken thing in the world of government policy: It *depends what you do*, and that is an active choice. So when people say, tell us what the train station concourse is going to be like in the future, I say, it depends what you do. So if we design it *without* gates, there won't be gates, and it'll look like this. We design it *with* gates, it'll look like this. But they're looking for some kind of implicit answer. There is no implicit answer; it depends what you do.

**SC:** Right.

**DH:** With some foresight work, one produces a series of scenarios, and we're trying to pick the most likely or something, and I'm saying, *intent* matters hugely here, and if you're a policymaker, *you're in charge*. But the policymakers I often work with in government, they've been so battered into a position of not having agency, or not believing they have agency, that — for instance, transport is a good example — they'll just kind of go with some sort of abstract model. “Well, we fed these numbers into the model that we've been using since the mid '90s, and it shows a marginal increase in cycling with a steady increase in car use.”

There wouldn't be, if you changed the policy. Then the model would change. But they're using the model to drive the policy, as opposed to saying, “What do we want to happen in the first place?”

**SC:** It's a disavowal of their capacity to design strategically.

**DH:** Their entire *raison d'être*. Because ultimately, if you follow that line of logic, then you just say, well, we'll just have some super smart model at some point. We can feed some assumptions into that, and then crank the handle, and some policy will pop out. If it was that simple then we wouldn't need policymakers. So you're kind of arguing yourself out of existing at some point... which is possibly what some are thinking!

I was working with a guy the other day from the infrastructure department. He represented this one mode of discourse, few other ways of thinking, or imagining, or visualising, or whatever. I was talking about road use and cities, and how we could shift the way that's happening. And he just said, “Well, all of the economic models we use show that road use is always central to the way the economy works.” I said “Change the model. Can you change the model?” Of course you can change the model — it's a model. Feed in some different data, or tweak the algorithm, to increase bike use and and decrease car use. Then you'll have a model that shows *decreased car use*.

Design is about making something happen, one way or another. You have to take it with a huge amount of humility, because I can say there *ought to be* this level of bike use, and put these schemes in place, but I don't really know how that would play out. So I suggest, well, make things adaptive, malleable, and stay in the project, learning, and pivot accordingly, and work your way through it.

That's not policy as a “predict, fire and forget” thing; it's an ongoing process. That'd be my actual answer to how you'd design for the future: make it adaptable, and keep adapting it from real-world interactions. But one can still have an intent, a direction, a trajectory — ideally, a positive outcome. It's amazing how infrequent that thought is, particularly in this world of the strategic design layer, which concerns the much harder policy objectives and systems change.

**SC:** Let's grant your observation, kind of a Herbert Simon-type observation, and something that a lot of designers intuit if not espouse explicitly, that what they're doing is future-making, no matter what or at what scale they're designing. If all design is future-making, but some cases are further future-making than others, what do you do differently when you're working in a more speculative or longer-range mode? I realise you have a sort of magpie's grab bag of tools; things that you've developed yourself, things that you've picked up from mentors, and developed on projects...

**DH:** As you say, magpie-like is a good way of thinking about it, because we're trying to find the right tool for the right question. If the question is mobility, and I'm a car guy, the answer looks like a car. But the question is mobility, not necessarily cars at all, so let's just open up to a full range of possibilities, including people moving less, or moving more slowly.

Let's look at how's it's actually going to work, in a low-carbon, sustainable, safe, zero road deaths, accessible, and healthy kind of way. If we plug all of those in as outcomes, I reckon it's probably going to involve things moving less, and people slowing down.

But I can't start with that, with the government in the room, because that's not seen as acceptable politically. I think the Overton Window concept is quite a useful one; what's politically acceptable at any one time. The window can move, and I'm trying to find ways of moving the window.

**SC:** How and when do you use experiential scenarios or design fiction mockups to address the Overton Window challenge?

**DH:** Well, we use them all the time. We're using them to flesh things out, to ask unspoken questions, to flush out assumptions. (Figure 2) We're also trying to get people motivated, frankly. Then we can say, "In that film, three people get into one vehicle, instead of three people getting into three vehicles; that's better for the city, isn't it?"

I'm trying to get them interested in those things, rather than the status quo. I'm gently pushing people beyond the bounds of what they're actually comfortable with, quite often, because I'm working with, let's say, a bunch of urban planners and the City Council, who are looking at models from yesterday around things like car use and ownership, or mobility generally, or the way that people live in houses, or energy, or whatever it might be.



Figure 2. Still from a 'sketch video prototype' for planning notice using an augmented reality (AR) interface, by Arup Digital Studio with Ericsson (2018)

So god knows what percent, 75 percent, of the ideas in the average drawing from me and my team are probably not going to happen. And that's hard to take. Because almost all of those things would lead to beneficial outcomes, to reference Simon again. But again, the humility says, even with the most convincing person in the world, it's not going to happen just like that. But if we can get 25 percent of them over the line, then fantastic. And if they're generative enough, then we can learn, go back and develop them. (Figure 3)

**SC:** Even if you accept the 75 percent failure rate as the cost of getting the 25 percent through, if you're playing the long game, you're seeding stuff for later, because it habituates them to seeing it. "Dan Hill actually presented that to us ten years ago, maybe it's time to give it a shot."

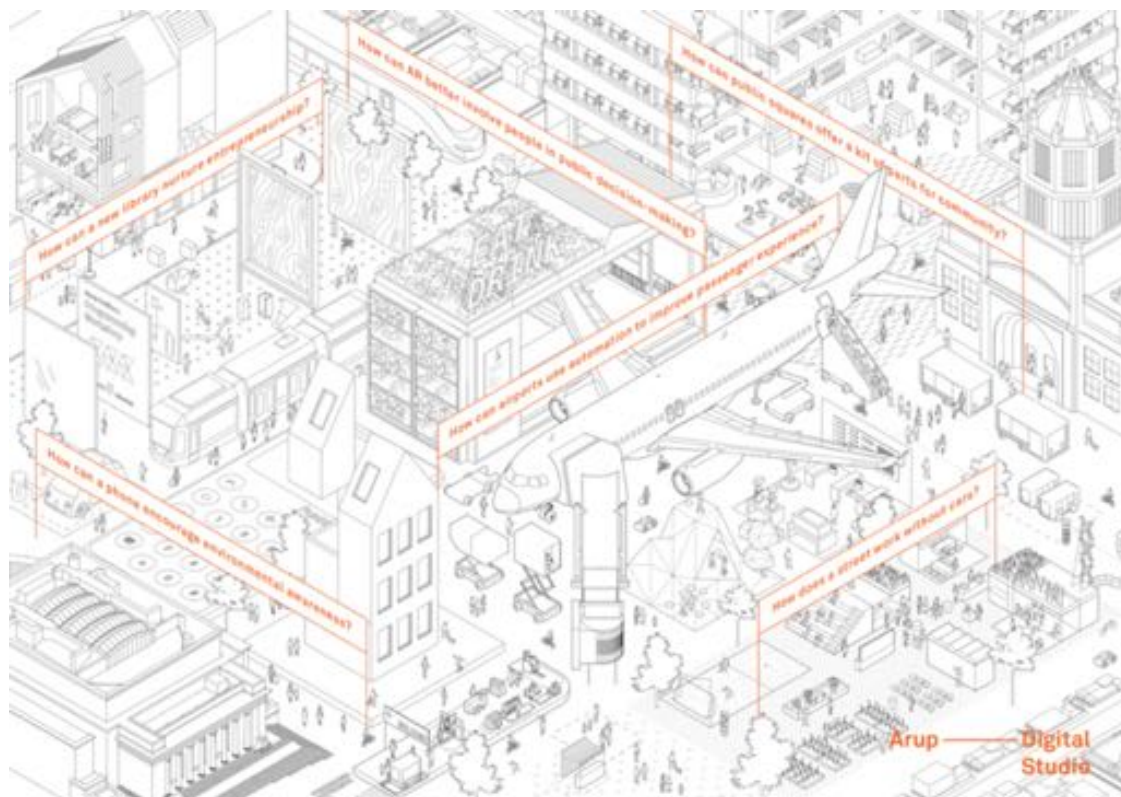

Figure 3. Asking questions with design. Drawing: Dan Hill / Arup Digital Studio

**DH:** Oh, a ton of what I do, actually, is less to do with specifically giving them a design solution that happens right now, and might just be changing their attitude, with a long, slow release of some kind. It's more generative that way, and they're driving it. It's not what I'm *intending* to do, necessarily – I would like to make the train station without the gates, because I think it would be a great space! – but it's kind of a drip release. And it's very hard to trace the effect of the work.

**SC:** This evaluation thing is a real challenge.

**DH:** Traceability, exactly. I was looking at what we did in Helsinki around the street food stuff. We made this Open Kitchen project on the back of the citizen-organized, *Ravintolapäivä* thing. I have this slide now with five or six different actual tangible outcomes, in law or policy or organisation change. And then just like a really awkward, wiggly line in between them! Because there's no way that I can say Open Kitchen did *that*, and *Ravintolapäivä* did *that*. But it definitely did have some effect, and you can sort of trace it a bit, but I know that those things don't happen without those things. But yeah, I cannot draw a straight line, which is usually what the world tries to make you do as a designer, or any kind of pseudo-professional.

**SC:** Right. It created an environment in which this later became possible.

**DH:** Exactly, and this is why I use this “dark matter” analogy, because it is kind of loose enough. It’s all about creating the conditions for things to happen.

**SC:** Is “drip feed” a strategic design vocabulary entry?<sup>1</sup> It should be!

**DH:** We have this sort of idea of something like a slow release, like a slow release drug in a system, but even that is a little bit too direct, because it’s going into culture, which is far more complex.

Maybe that’s also why, as you said, my practice, for want of a better word, is magpie-like, because I’m trying different things. And so for someone, I might think it’s a movie that will do the job; someone else it might be a conversation; something else it might be an event, or for something else we need to make a newspaper. And then there are books and writing, and I enjoy making all of those things as well, as craft. But there’s a constant searching and trying to figure out: what is the thing for this thing, that will trigger a response?

**SC:** I really like your idea of your design function as a kind of general practitioner and a first port of call, and you can refer clients on to the specialists as and when that’s appropriate, rather than starting with “what you need is a building”.

**DH:** Absolutely, you can’t start with a specialism. A hammer only sees nails.

## Correspondence

Dan Hill  
Vinnova  
Mäster Samuelsgatan 56  
Stockholm 10158  
Sweden  
<http://www.cityofsound.com>  
E-mail: [cityofsound@gmail.com](mailto:cityofsound@gmail.com) & [dan.hill@vinnova.se](mailto:dan.hill@vinnova.se)

## Notes

1. Hill, D. (2012). *Dark matter and Trojan horses: A strategic design vocabulary*. Moscow: Strelka Press.

This text is an edited transcript of a conversation that took place at the First Futurological Congress in Berlin, hosted by the Dubai Future Foundation, on 21 July 2018.

# What If There Were More Policy Futures Studios?

Lucy Kimbell  
University of the Arts London  
UK

**Keywords:** Design, Experiential Futures, Governance, Participatory Design, Public Policy, Public Sector Foresight.

Unexpected election results are intersecting in new and often disturbing ways with enduring issues such as economic and social inequalities; climate change; global movements of people fleeing war, poverty and environmental change; and the social and cultural consequences of long-term cuts in public funding. These developments are punctuated by dramatic events such as war, terrorist attacks and disasters such as floods, fires and other effects of changes in rainfall and temperature. Many of the available public policy visions of the future fail to connect with people's day-to-day realities and challenges they face. Where could alternative visions and more effective public policy solutions come from? And what roles can design and futures practices play in constituting these?

For people using design-based and arts-based approaches in relation to social and public policy issues, the practices, structures and processes associated with institutions making public policy present a paradox.<sup>1</sup> On the one hand, creative methods can enable people to participate in assessing how things are, in ways that are meaningful to them, and imagining how things could be different, and to do so in collaboration with people they might not ordinarily engage with. Workshops and spaces for exploring futures such as design jams, hackathons, digital platforms, exhibitions and co-working hubs can open up a distributed creative capacity for negotiating potentialities in relation to current actualities. The strong emphasis in design on how people experience issues – understanding things on their terms, informed by the principles of ethnography – can open up participation, critique and creativity. Such practices can surface and open up difficult questions about institutions and how they work.

On the other hand, such approaches often do not lead to the hoped-for results. Having agency in co-design workshop does not replace the need for having agency in your home, neighbourhood, place of study, play, worship, or work, in your communities or the wider world. Such initiatives do not replace the need for political parties and public administrations to have visions, policies and plans that connect with people's lived realities and the means to achieve them. Nor do such approaches have the same legitimacy or accountabilities as the established practices, structures and processes in the institutions they intervene into. Further, design-based methods for involving people in exploring futures do not scale easily. The kinds of expertise required to facilitate exploratory futures processes and spaces are not well understood and cannot be easily reproduced. In addition, the close relationships between design practice, consumer marketing and the tech industry situated within Eurocentric modernism means that design's methods are intimately tied up with particular kinds of socio-technical imaginaries.<sup>2</sup>

Set against this tension, the question I want to explore here is the potential of combining design and futures approaches in (re)imagining public policy making, by (re)connecting people's experiences with policy infrastructures, processes and practices. To do this, I review briefly some current ways of thinking about how policy options can be explored and anticipated, drawing on research in foresight. Then, using

examples from activities by public servants developing new kinds of policy making practices, I summarise the characteristics of what I call the ‘policy futures studio’. Rather than necessarily being a team, or unit, such a studio can be a distributed set of capabilities. Together these capabilities can enable the inventive co-emergence of future ways of living, being and working that connect policy infrastructures and processes with people’s lived experiences of issues.

## Exploring Policy Futures

Policy making practices and institutions are in flux. Increasing digitisation of data, media and communications, and innovations in ways of organising and delivering services, intersect with political, often neo-liberal, exhortations to reduce public investment, empower corporations, or require individuals to find solutions to policy problems (Peck & Theodore, 2015). Changes to policy making is taking place in central, regional and local government around the world, sometimes in the form of ‘policy labs’ (Williamson, 2016). Gatherings of such labs and professionals working with them (e.g. Nesta, 2015; EU Policy Lab, 2016; Service Design in Government, 2019) emphasise the sharing of knowledge among peers, cross-institutional connections, and illustrate the range of policy domains and scales within which new approaches are being tried out.

Sometimes called ‘open government’ (e.g. OGP, 2011), these developments include:

- Evidence-based policy, premised on the idea of demonstrating “what works” and using this to inform priorities, directions and investments with a particular emphasis on translating insights from the social sciences (e.g. Breckon, 2015).
- Broadening participation in developing policy and using a wider range of evidence including big data analysis, sharing public and administrative data as well as ethnography (e.g. Verhulst & Caplan, 2015).
- Experimentation in policy making by trying out ideas before applying them at scale, for example through randomised control trials based on applying behavioural insights (e.g. John, Cotterill, Richardson, Moseley, Stoker, Wales, & Smith, 2011) but also small-scale policy prototyping (e.g. Policy Lab 2016; Chari, 2018).

In the context of this ongoing experimentation, two domains of professional practice are increasingly tied up with the new policy practices: futures and design.

There is a long-standing relationship between futures practices and research and public policy recognising the need for elected leaders and staff in public administrations to make decisions amid high levels of complexity and uncertainty about outcomes (Urry, 2016). A range of approaches and methods from forecasting to scenario planning are used. However, one review of the use of scenario planning in public policy highlighted the uncertain results from developing and using scenarios, and the importance of political and institutional cultures in shaping their effectiveness (Volkery & Ribeiro, 2009). Some governments have invested in building up an internal capability in exploring futures and encouraging a wider capability and ecosystem to shape policy making. For example, Fuerth’s description of *anticipatory governance* argued that governments should develop capabilities in foresight, which he defined as “the capacity to anticipate alternative futures, based on sensitivity to weak signals, and an ability to visualize their consequences, in the form of multiple possible outcomes” (Fuerth, 2009, p. 16). Advocating a systems approach to futures, Fuerth argues that complexity theory, with its emphasis on non-linearity and interdependency, is an important way to think about how policy should be formulated. A scaleable foresight capability for government requires four sub-systems, according to Fuerth: a foresight system; a system to integrate foresight into the policy process; a feedback system to assess performance and manage institutional knowledge; and an open-minded institutional culture (Fuerth, 2009, p. 20). To build up anticipatory governance requires changes to institutional norms and cultural practices.

Elsewhere, in his study of three countries' strategic foresight activities, Habegger identifies two ways they contribute to public policy making. The first is to provide systematic knowledge about trends and developments in the wider environment. The second, more significant, benefit is the mutual learning processes and networks created across professional communities and policy areas (Habegger, 2010, p. 56). These researchers highlight that while the outputs of strategic foresight or scenario planning, such as reports, can be important within governance contexts, it is the open-minded, curious and analytical capacity to change how policy making is done that is of value.

In contrast, the professional domain of design has only recently become more visible as a field of practice and research engaging with public policy making. Over the past decade, the practices, expertise and methods associated with late 20th century design studios have been reworked in relation to complex, fast-changing and dynamic social and policy issues (Bason, 2017; Kimbell & Julier, 2019). Packaged up as design thinking, agile collaboration, service design or other variants, different versions of designerly expertise are being deployed in relation to complex public and organisational challenges. Bringing design into policy contexts brings a focus on the practical generation and exploration of new ideas that allow policy specialists to collaborate across silos and surface the perspectives of beneficiaries and citizens (Bason, 2014; Kimbell, 2015a). For example Christiansen and Bunt (2014) suggest that policy making is reconfigured through design in four ways: By providing a focus on outcomes, rather than solutions; creating systems that enable post-production, rather than stand-alone services; experimenting to produce the grounds for conviction; and by recognising and exercising a new type of authority that is distributed, rather than hierarchical. Thus as with futures expertise, design, too, has the potential to change policy making practice but is also hampered by deep-seated institutional norms and political realities (Bailey & Lloyd, 2016).

As these new policy practices emerge, there are indications that the capacity of futures and design to *anticipate and explore futures in the present* has the potential to contribute significantly to enabling policy makers to mediate collectively between what is and what could be. Whereas evidence-based policy rests on producing valid and reliable evidence about things in the past to guide future action, anticipatory foresight practices such as scenario planning emphasise mutual learning between producers and consumers of insight in relation to dynamic change (Ramírez & Wilkinson, 2016). Here, the practices associated with the design studio materialise possibilities that make conversations about the future specific, tangible and meaningful, providing ways to build “evocative stories” (Miller, 2007) about futures that can bring people together to assess pathways and make decisions. Design and futures use methods that constitute publics, data and problems in ways that can result in changes to issues, but which also open them up. As Lury and Wakeford put it, such *inventiveness* exists in

*The relation of two moments: the addressing of a method – an anecdote, a probe, a category – to a specific problem, and the capacity of what emerges in the use of that method to change the problem (Lury & Wakeford, 2012, p. 7).*

Viewed through the lens of “inventive” social research (Marres, Guggenheim, & Wilkie, 2018), futures and design can be seen as a collective capacity to bring publics and policy issues into view and in so doing, to open them up. Recent examples of the application of design and futures approaches to contemporary policy problems provide insights into how the practices associated with futures and the design studio mediate between current actualities and future potentialities. In what follows, I sketch out the characteristics of the ‘policy futures studio’, drawing on examples from recent experiments in policy development. Most of these come from the work of Policy Lab, a multi-disciplinary team in the UK government’s Cabinet Office exploring new ways of making policy, with whom I worked closely for a year.<sup>3</sup> Figure 1 visualises the key concepts from futures, policy and design that policy futures studio brings into relation with one another.

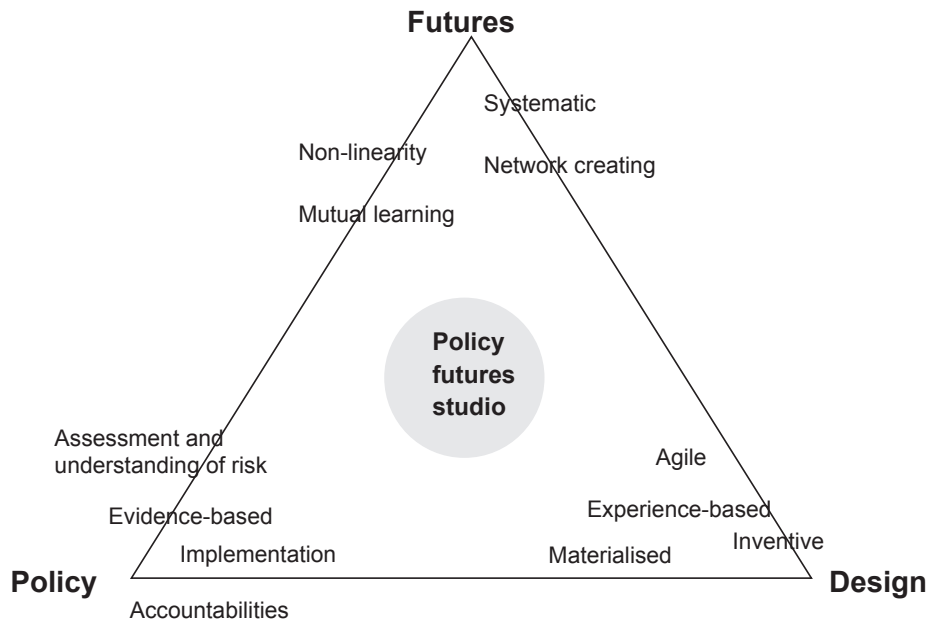

Figure 1. The policy futures studio

## Characteristics of The Policy Futures Studio

*Publics and problems revealed as “in the making”.* A policy futures studio does not start with a pre-defined public or issue. Its activities and outputs materialise a public and issue and make it available for others to engage with through a process of anticipatory action learning (Inayatullah, 2006; LeDantec & DiSalvo, 2013). For example, I was involved in supporting a Policy Lab when they facilitated a two-day “policy sprint” using an agile methodology as part of a project with officials from two government departments (Drew, 2015a). The policy sprint positioned the officials, front line staff and people with contextual and local knowledge of the issue and other stakeholders as involved in a collective inquiry. The policy sprint process included reviewing existing data of different kinds, identifying gaps in current knowledge (especially regarding the experiences of beneficiaries and citizens in the policy domain), and scoping a research and design project to create insights and co-design new ideas to inform policy. Its outcomes included turning a group of individuals from across government into a team with a capacity to work across organisational and knowledge boundaries to inquire into the policy issue and explore options together.

*Materialising potential futures as people experience them.* Experience-based or “human-centred” design focuses on people’s experiences of issues and potential solutions. This attentiveness to the micro-social worlds in which policy issues exist reveals new insights that may be hard to grasp from the institutional centres of power, through the lenses of experts or via large-scale data analysis. It also provides ways for officials, service providers, researchers and other stakeholders to engage with one another across their disciplinary and organisational boundaries. Described as a way for practitioners to engage people more deeply in exploring futures, using a variety of forms, formats, and media broadens participation and engages a collective intelligence in exploring possibilities (Candy & Dunagan, 2016). For example, a cardboard model of a health centre realised via “table-top prototyping” (Kimbell, 2015b) produced by public servants in a workshop organized by Policy Lab made a potential new policy graspable but also revealed aspects of the challenges to which this provisional solution responded. Visualisations and artefacts produced by Policy Lab associated

with potential future scenarios enabled policy makers to imagine and assess possible developments relating to the maritime industry (Miller, 2019). Such outputs are moments of synthesis (Fariás & Wilkie, 2015) within a collective negotiation between what is and what could be. As well as being models of potential future arrangements, such materialisations of potential solutions are models to think with.

*Zooming in and out.* Public policy problems (and their solutions) are bundles of regulation, institutional and social practices, technologies and current ways of imagining society, now and in the future. Normann (2001) introduced the idea of the crane to help managers recognise the different conceptual levels of an issue they were working at. Using the crane to shift between higher and lower orders of cognition allows participants to see an issue within a larger context. Similarly, causal layered analysis prompts analysis of related “layers” of a policy future, enabling participants to identify and surface core myths and metaphors, discourses, social causes and trends (Inayatullah, 2005). Surfacing institutional factors, such as the tendency of large bureaucracies to replicate norms and come to resemble one another (DiMaggio & Powell, 1983), draws attention to the social silences and assumptions that play out in policy development. Working at different sites and scales within a policy issue is part of the ‘studio’ approach, which moves between being attentive to people’s situated experiences of an issue and institutional and organizational perspectives.

*Translating between different kinds of data and expertise.* In a world awash with data and committed to the ongoing production of yet more, the policy futures studio plays an important role in translating between different kinds of evidence, insights and opportunities. The policy futures studio problematizes, rather than taking as given the data, methods to analyse it and generate insights from it, and the activities which make these graspable to policy officials, delivery staff and other actors in the ecosystem. No single expertise is adequate to addressing policy problems. Instead, multiple kinds of expertise can be brought together to explore issues and generate solutions. For example, during a two-day “data studio” I organized about food poverty, participants found themselves challenged to represent an aspect of the issue using materials such as string and pegs, textiles or Lego (Drew, Bennett, & Kimbell, 2016). Going through a deliberative, collaborative process of exploring how to represent an aspect of food poverty enabled participants to generate insights into the issue and into their own disciplinary and cultural framings, as well as making food poverty researchable. In a project involving Policy Lab, designers synthesised and visualised a broad range of evidence on the future of aging produced by the UK Government Office of Science to enable a group of people to digest and make sense of the findings (Drew, 2015b). The policy futures studio enables a shift from evidence-based policy based on past results, to recombining different sources and kinds of data into materialised framings of policy issues that anticipate potential solutions, institutional implications and (re)configurations of resources involved.

*Opening up participation.* Collaborative design approaches co-exist with other kinds of approach within and across organisations and locations, often connecting between them and engaging broader publics. Whilst not playing down the ethical and political aspects of participation and of data infrastructures (eg Gray, Gerlitz, & Bounegru, 2018), digital resources are one increasingly visible means to enable such connections. Idea generation and development platforms can open up participation in the process of designing in relation to a challenge. Organisations such as multi-national agencies, foundations and government departments set a challenge via the platform, which mobilises responses from a self-organising, distributed public. An example is “How might urban slum communities become more resilient to the effects of climate change?” set by the UK government’s Department for International Development and the Global Resilience Partnership (OpenIDEO, 2016). Through research, idea generation, feedback, improvement, and impact phases, the platform guides participants through a design process with the intention to produce implementable solutions for the challenge partner to invest in. Similarly, formats such as exhibitions which materialise in various media different aspects of futures can engage a broader audience in

discussing those aspects. For example, The Museum of Future Government Services, a temporary event within the United Arab Emirates Government Summit, included mock-ups of future public services to provoke debate (Museum of Future Government Services, 2015).

## Conclusion

This essay has argued that public policy making is a relevant site to use the material practices of the design studio and anticipatory learning to materialize and open up futures, which can shape current framings and enable strategic conversations. Brief examples demonstrated that expertise associated with design is already being deployed in government policy teams within different institutional formats, in dialogue with other ways of analysing evidence and exploring futures. Recombining some of this into a proposal for a “policy futures studio” foregrounds policy-in-the-making as a collective, embodied practice that brings publics into view as co-researchers in exploring issues and co-designers anticipating policy solutions at different scales and within different timeframes.

Returning to the themes introduced earlier — limited visions on offer from policy makers, disconnects from people’s experiences and their lack of agency — what might such policy futures studios offer? Whilst avoiding grand or naïve claims that design and futures practices can counteract current lack of visions or effective policy solutions, the characteristics outlined above suggest such expertise can be productive. Studios enable people to make problems graspable and imaginable in the face of high levels of ambiguity, complexity and uncertainty. They translate between local, digital and expert knowledge and data and bring into view their different grounding myths, discourses and framings. They materialise and allow exploration of provisional policy solution-bundles and reveal the networks of resources and institutional narratives, practices and norms that are implicated within them. Policy futures studios will not design definitive solutions, but they may design better problems.

## Acknowledgement

This essay draws on research supported by the UK Arts and Humanities Research Council (AHRC) through a fellowship during 2014-15, and research with Guy Julier funded by the AHRC through grants AH/L503952/1 and AH/N504269/1.

## Correspondence

Lucy Kimbell  
Social Design Institute  
University of the Arts London  
UK  
E-mail: l.kimbell@arts.ac.uk

## Notes

1. In relation to these questions, I enjoy a privileged situation, employed (for now) full-time by a university and living in a country with relatively stable institutions, although these are under threat.
2. See Julier (2017) for a critical take on contemporary design cultures.
3. See Kimbell 2015a.

## References

- Bailey, J., & Lloyd, P. (2016). The introduction of design to policymaking. *Proceedings of DRS2016: Design Research Society Conference* (pp.3619-3633). doi:10.21606/drs.2016.314
- Bason, C. (Ed). (2014). *Design for policy*. Aldershot, UK: Gower.
- Bason, C. (2017). *Leading public design. Discovering human-centred governance*. Bristol: Policy Press.
- Breckon, J. (2015). *Better public services for experimental government*. Alliance for Useful Evidence.
- Candy, S., & Dunagan, J. (2016). The experiential turn. *Human Futures*, 1(1), 26-29. Retrieved from <https://www.researchgate.net/publication/311910011>
- Chari, V. (2018, November 28). Prototyping for policy. Open Policy Blog. Retrieved from <https://openpolicy.blog.gov.uk/2018/11/27/prototyping-for-policy/>
- Christiansen, J., & Bunt, L. (2014). Innovating public policy: Allowing for social complexity and uncertainty in the design of public outcomes. In C. Bason (Ed.), *Design for policy* (pp.41-56). Aldershot, UK: Gower.
- DiMaggio, P., & Powell, W. (1983). The iron cage revisited: Institutional isomorphism and collective rationality in organizational fields. *American Sociological Review*, 48(2), 147-160.
- Drew, C. (2015a, January 28). Testing policy sprints. Open Policy Blog. Retrieved from <https://openpolicy.blog.gov.uk/2015/01/28/testing-policy-sprints/>
- Drew, C. (2015b, February 26). Policy making through possible futures. Retrieved from <https://openpolicy.blog.gov.uk/2015/02/26/policy-making-through-possible-futures/>
- Drew, C., Bennett, S., & Kimbell, L. (2016, August 1). Designing data. Open Policy Blog. Retrieved from <https://openpolicy.blog.gov.uk/2016/08/01/designing-data/>
- EU Policy Lab. (2016). Lab Connections. <http://blogs.ec.europa.eu/eupolicylab/lab-connections>
- Farías, I., & Wilkie, A. (2015). *Studio studies: Operations, topologies and displacements*. London: Routledge.
- Fuerth, L. S. (2009). Foresight and anticipatory governance. *Foresight*, 11(4), 14-32. doi:10.1108/14636680910982412
- Gray, J., Gerlitz, C., & Bounegru, J. (2018). Data infrastructure literacy. *Big Data and Society*, 5(2). doi.org/10.1177/2053951718786316
- Habegger, B. (2010). Strategic foresight in public policy: Reviewing the experiences of the UK, Singapore, and the Netherlands. *Futures*, 42(1), 49-58. doi:10.1016/j.futures.2009.08.002
- Inayatullah, S. (2005). *Questioning the future: Methods and tools for organizational and societal transformation*. Taipei: Tamkang University Press.
- Inayatullah, S. (2006). Anticipatory action learning: Theory and practice. *Futures*, 38(6), 656-666. doi:10.1016/j.futures.2005.10.003
- John, P., Cotterill, S., Richardson, L., Moseley, A., Stoker, G., Wales, C., & Smith G. (2011). *Nudge, nudge, think, think: Using experiments to change civic behaviour*. London: Bloomsbury.
- Julier, G. (2017). *Economies of design*. London: Sage.
- Kimbell, L. (2015a). *Applying design approaches to policy making: Discovering policy lab*. Brighton: University of Brighton.
- Kimbell, L. (2015b, March 3). Prototyping in government workshop. Open Policy Blog. Retrieved from <https://openpolicy.blog.gov.uk/2015/03/03/open-policy-2015-prototyping-in-government-workshop/>
- Kimbell, L., & Julier, G. (2019). Confronting bureaucracies and assessing value in the co-production of social design research, *CoDesign*, 15(1), 8-23. doi:10.1080/15710882.2018.1563190
- LeDantec, C. A., & DiSalvo, C. (2013). Infrastructuring and the formation of publics. *Social Studies of Science*, 43(2), 241-264. doi:10.1177/0306312712471581

- Lury, C., & Wakeford, N. (Eds). (2012). *Inventive methods: The happening of the social*. London: Routledge.
- Marres, N., Guggenheim, M., & Wilkie, A. (eds.) (2018). *Inventive social research*. Manchester: Mattering Press.
- Miller, B. (2019). Co-design in policy: learning by ‘doing’. Open Policy Blog. Retrieved from <https://openpolicy.blog.gov.uk/2019/01/11/co-design-in-policy-learning-by-doing/>
- Miller, R. (2007). Futures literacy: A Hybrid Strategic Scenario Method, *Futures*, 39(4), 341-362.
- Museum of Future Government Services. (2015). Retrieved via Internet Archive <https://web.archive.org/web/20150213013352/http://museum.governmentsummit.org/2015/>
- Nesta. (2015). Labworks. Retrieved from <http://www.nesta.org.uk/event/labworks-2015>
- Normann, R. (2001). *Reframing business: When the map changes the landscape*. Chichester, UK: Wiley.
- OGP. (2011). Open Government Declaration. Retrieved from <http://www.opengovpartnership.org/about/open-government-declaration>
- OpenIDEO. (2016). How might urban slum communities become more resilient to the effects of climate change? Retrieved from <https://challenges.openideo.com/challenge/urban-resilience/brief>
- Peck, J., & Theodore, N. (2015). *Fast policy: Experimental statecraft at the thresholds of neoliberalism*. Minneapolis: University of Minnesota Press.
- Policy Lab (2016, February 17). Prototyping a new health and work service. Open Policy Blog. Retrieved from <https://openpolicy.blog.gov.uk/2016/02/17/prototyping-a-new-health-and-work-service/>
- Ramírez, R., & Wilkinson, A. (2016). *Strategic reframing: The Oxford scenario planning approach*. Oxford: Oxford University Press.
- Service Design in Government. (2019). Retrieved from <https://govservicedesign.net/2019/>
- Urry, J. (2016). *What is the future?* Cambridge: Polity Press.
- Verhulst, S., & Caplan, R. (2015). *Open data: A twenty-first-century asset for small and medium-sized enterprises*. New York: GovLab.
- Volkery, A., & Ribeiro, T. (2009). Scenario planning in public policy: Understanding use, impacts and the role of institutional context factors. *Technological Forecasting & Social Change*, 76, 1198-1207. doi:10.1016/j.techfore.2009.07.009
- Williamson, B. (2016). Digital education governance: data visualization, predictive analytics, and ‘real-time’ policy instruments. *Journal of Education Policy*, 31(2), 123-141. doi:10.1080/02680939.2015.1035758

# Your Move: Lessons Learned at The Interstices of Design, Gaming, And Futures

Aaron Rosa  
Fraunhofer Institute for Systems and Innovation Research  
Germany

John A. Sweeney  
Narxoz University  
Kazakhstan

**Keywords:** Foresight in Government, Experiential Futures, Game Design.

---

*When human beings create and share experiences designed to delight or amaze, they often end up transforming society in more dramatic ways than people focused on more utilitarian concerns (Johnson, 2016, p. 12).*

In *Wonderland: How Play Made the Modern World*, Johnson maps an alternative history of innovation that focuses on how play has led to major societal shifts. This sentiment echoes the work of many scholars who have examined the ‘play’ function of human behavior as related to social organization (Huizinga, 1949), the creation of culture (Caillois, 2001), and building essential social and cognitive skills (Dewey, 1938). It may come as little surprise then that at the dawn of the printing press, second only to the Gutenberg Bible, the most popular printed book was Cessolis’s *The Game of Chess*, propelling the game into a global phenomenon that continues to exert an influence on a variety of spheres from strategic studies to computer science (Shenk, 2011).

Gaming and simulations have been used by futurists for decades, but there has been a veritable explosion of game-based and design-driven approaches and tools in recent years. Inclusive and accessible approaches to foresight are critical to the alternative futures method and theory as practiced at the “Manoa School.” (Dator, 2009; Jones, 1992). The indeterminate and open nature of a plurality of possible futures — “the future does not exist, but alternatives futures can and should be forecast...” (Dator, 1995) — makes seeking out diverse perspectives, political and ethical positions, and imaginaries a necessity for equitable and representative foresight (Inayatullah, 1998). This diversity of perspectives encourages the use of different media to communicate about futures, and we have found that different aspects of play and games — ambiguity, universality, and social creation — makes them a widely applicable mode of conducting futures-oriented research. In projects with governments, international agencies, and various civil society and educational organizations, we have made it a point to reinforce the necessity for more participatory modes of examining and/or exploring futures and action learning (Ramos, 2002). Our primary aim is not to design games and experiences *for* people, but rather to find dynamic and collaborative ways to design games and experiences *with* people.

Games are spaces of possibility, with participants navigating and acting according to the boundary conditions of a rule set (Salen & Zimmerman, 2004). It is the freedom of movement within this bounded space that excites and inspires playful activities. The act of play relies on these boundaries to refine its otherwise ambiguous nature — discerning both telos (purpose) and pathos (mood) from the parameters of the game (Sutton-Smith, 1997) — and those rules must be agreed upon by all participants (Huizinga, 1949; Fullerton, 2014). In terms of futures research, the world-building that accompanies gameplay (bounding a space with rules and entities) aligns nicely with the processes of creating an image of the future (Dator, 2009). Implicitly, games are social compacts, requiring an agreement between participants in order to be played. As such, they can be understood as negotiated systems of governance, and it is this aspect that ties our work in the co-development of game systems more closely to the goals of foresight. Working with governance institutions and agencies, we have found that game development allows our partners to imagine new modes of governing in regards to long-term futures.

In the past five years or so we have designed and developed a range of card-based tabletop games, an online gaming platform, numerous live action role-playing (LARP) experiences, and a hybrid game featuring mobile augmented reality and experiential futures — all aiming to evoke the deep-seated inclination that humans have toward play in various forms (Huizinga, 1949). For one project, part of a research grant on the relationship between communication technologies and power relations, specific data outputs were necessary; knowing this dramatically shaped the construction of *Gaming Futures*, a hybrid game featuring experiential scenarios and mobile augmented reality (Dator, Sweeney, Yee, & Rosa, 2013). There is a well-documented precedence for such games' efficacy in creating socially transformative experiences and generating collective intelligence (McGonigal, 2003, 2008). Such work has also inspired attempts at a more formal design language for ARGs or alternate reality games (Dena, 2007; Montola, Stenros, & Waern, 2009; Stewart, 2006), though constant evolution in this area has made consistent terminology elusive. For *Gaming Futures*, play centered on the exploration and deepening of four alternative futures, which were transcribed into one-act dramatic “experiential scenarios” (Candy, 2010), which the players acted out after navigating the city on a virtual pathway to learn about their specific scenario (cf. Walz, 2010; Alfrink, 2014). We developed a series of “street artifacts” built using mobile augmented reality, which is to say that we layered alternative futures for Honolulu over the present cityscape (Dator et al., 2013). (See Figure 1.)



Figure 1. Gaming Futures (Mapped locations for Set 1 Experiences) (2012)

This led to the emergence of an “experientially augmented toolset,” raising a number of key questions and insights for us as researchers, practitioners, and designers (Candy & Dunagan, 2017). Getting the language or phrasing right when designing a game is everything, and we are firm believers in iterative processes that enable this. Many of our projects have been dual-language, requiring careful attention to both translation of both critical terminology and cultural sensitivities. While working with the United Nations in what is now The Republic of North Macedonia, for example, we had to use the moniker “enhanced survey tool” rather than game; even “serious game” was to be avoided due to concerns that the government might not take to such playfulness.

Acquiring essential information about the target player group helps narrow design parameters and create a better overall experience. In line with insights from research into learning (Dewey, 1938; Gee, 2004), fostering a positive experience for players reinforces engagement and aids in their retention of information. As our work usually centers on designing engagements for specific audiences, we conduct a scoping mission with our partners before commencing the design process, focusing on who will be playing the game, and who will be looking at the results (Inayatullah, 2006). In the project *RIPPLE*, we knew that our players would be civil service professionals in Singapore, and results would be viewed by multiple futures research groups. As such, content and mechanics had to be designed with different audiences in mind, even if they shared the same general purpose.

Designing a complex versus a simple game is not a black or white matter. It is often the case that less is more, and we have seen what happens when the “expansion pack” mindset takes hold. One of the best metrics for measuring, or at least considering, a game’s complexity is *time*. A game that can be learned, or even played, in under 10 minutes clearly needs to be simple. We have benefited from designing games that use a simple pattern (card-tokens-card-repeat), and this cadence has allowed relatively complex data outputs to be generated for planning and policy development. For a project with the United Nations Development Programme in Tonga, we devised a game revolving around the placement of cards, but the first person to place a card exercised a great deal of power, so we used this to challenge gender norms by having a young female player commence the exercise.

Addressing game mechanics — the rules by which play is conducted, the formal definition of game objects, and their relationship to one another — must always be balanced with player experience (Koster, 2013). Experiences, however, are never homogeneous. They are subjective, anticipatory, reactive, and highly emotional, especially when dealing with futures-related content. As many of our designs feature an “in-casting” approach, we often give players a wide degree of latitude to push the boundaries of what is possible with regard to both content and form, but this does not suit all audiences and engagements (Dator, 2009). This is where game design, as with futures practice, is as much an art as a science. Game mechanics set things into motion (and also preclude some things from happening), and player actions are always accompanied by expectations as to how those mechanics function (Schell, 2014). When mechanics and expectations align well, players can engage in a high level of strategy, which is extremely useful for futures-oriented engagements (Salen & Zimmerman, 2004).

The only real way to find out if your design is operable — if the player experience is aligning with your goals; if it is producing the desired outputs and learning outcomes — is to test, refine, and repeat (Fullerton, 2014). Play with novices. Play with experts. Find fresh sets of eyes and ears. After each testing session, be prepared to rethink your approach, and leave your ego at the door. We have had to make major shifts pretty late in the design process, and while this is not desirable or advisable, it is sometimes necessary and can lead to a better play experience. We have benefited immensely from the insights of colleagues as well. Different configurations of players will likely reveal things that you would have never discovered on your own — exploits, surprises, and seemingly off-the-wall suggestions that could radically change the game (often for the better). We view the increasing number of engagements blending design, gaming, and futures as a move in the right direction.

## Correspondence

Aaron Rosa  
Fraunhofer Institute for Systems and Innovation Research  
Germany  
E-mail: Aaron.Rosa@isi.fraunhofer.de

John A. Sweeney  
Narxoz University  
Kazakhstan  
E-mail: johnasweeney@gmail.com

## References

- Alfrink, K. (2014). The gameful city. In S. P. Walz & S. Deterding (Eds.), *The gameful world: Approaches, issues, applications* (pp. 527–560). Cambridge, MA: MIT Press.
- Caillois, R. (2001). *Man, play, and games*. University of Illinois Press.
- Candy, S. (2010). *The futures of everyday life: politics and the design of experiential scenarios* (PhD Dissertation). Department of Political Science, University of Hawaii at Manoa. doi:10.13140/RG.2.1.1840.0248
- Candy, S., & Dunagan, J. (2017). Designing an experiential scenario: The people who vanished. *Futures*, 86, 136-153. doi:10.1016/j.futures.2016.05.006
- Dator, J. (1995). What futures studies is, and is not. Hawaii Research Center for Futures Studies. Retrieved from <http://www.futures.hawaii.edu/publications/futures-studies/WhatFSis1995.pdf>

- Dator, J. (2009). Alternative futures at the Manoa School. *Journal of Futures Studies*, 14(2), 1-18. Retrieved from <http://www.jfs.tku.edu.tw/14-2/A01>
- Dator, J., Sweeney, J. A., Yee, A., & Rosa, A. (2013). Communicating power: Technological innovation and social change in the past, present, and futures. *Journal of Futures Studies*, 17(4), 117-134. Retrieved from <https://jfsdigital.org/wp-content/uploads/2013/10/174-R01.pdf>
- Dena, C. (2007). Creating alternate realities. In F. von Borries, S. P. Walz, & M. Böttger (Eds.), *Space Time Play: Computer games, architecture and urbanism: The next level* (pp.238-241). Basel: Birkhäuser.
- Dewey, J. (1938). *Experience and Education*. New York, NY: Kappa Delta Pi.
- Fullerton, T. (2014). *Game design workshop: A playcentric approach to creating innovative games* (3rd ed.). Boca Raton, FL: CRC Press.
- Gee, J. P. (2004). *Situated language and learning: A critique of traditional schooling*. New York: Routledge.
- Huizinga, J. (1949). *Homo ludens: A study of the play-element in culture*. London: Routledge & Kegan Paul.
- Inayatullah, S. (1998). Causal layered analysis: Poststructuralism as method. *Futures*, 30(8), 815-829. doi:10.1016/S0016-3287(98)00086-X
- Inayatullah, S. (2006). Anticipatory action learning: Theory and practice. *Futures*, 38(6), 656-666. doi:10.1016/j.futures.2005.10.003
- Johnson, S. (2016). *Wonderland: How play made the modern world*. New York: Penguin Random House.
- Jones, C. B. (1992). The Manoa School of futures studies. *Futures Research Quarterly*, 8(2), 19-25.
- Koster, R. (2013). *Theory of fun for game design*. Sebastopol, CA: O'Reilly.
- McGonigal, J. (2003). A real little game: The performance of belief in pervasive play. Conference Proceedings of the Digital Games Research Association (DiGRA), Level Up. Retrieved from <https://www.avantgame.com/MCGONIGAL%20A%20Real%20Little%20Game%20DiGRA%202003.pdf>
- McGonigal, J. (2008). Why I love bees: A case study in collective intelligence gaming. In K. Salen (Ed.), *The ecology of games: Connecting youth, games, and learning* (pp.199-227). Cambridge, MA: MIT Press. doi:10.1162/dmal.9780262693646.199
- Montola, M., Stenros, J., & Waern, A. (2009). *Pervasive games: Theory and design*. Burlington, MA: Morgan Kaufmann Publishers.
- Ramos, J. M. (2002). Action research as foresight methodology. *Journal of Futures Studies*, 7(1), 1-24. Retrieved from <https://jfsdigital.org/wp-content/uploads/2014/06/071-A01.pdf>
- Salen, K., & Zimmerman, E. (2004). *Rules of play: Game design fundamentals*. Cambridge, MA: MIT Press.
- Schell, J. (2014). *The art of game design: A book of lenses* (2nd ed.). Boca Raton, FL: CRC Press.
- Shenk, D. (2011). *Immortal Game: A History of Chess*. Souvenir Press.
- Stewart, S. (2006). Collaborating with the audience: Alternate reality games. <http://www.seanstewart.org/collaborating-with-the-audience-alternate-reality-games/>
- Sutton-Smith, B. (1997). *The ambiguity of play*. Cambridge, MA: Harvard University Press.
- Walz, S. P. (2010). *Toward a ludic architecture: the space of play and games*. Pittsburgh, PA: ETC Press.



# Using the Future at NASA

**David Delgado**  
NASA JPL  
USA

**Stuart Candy**  
Carnegie Mellon University  
USA

*David Delgado is a Visual Strategist at NASA JPL, the National Aeronautics and Space Administration's Jet Propulsion Laboratory, a United States federal research and development centre located in Pasadena, California.*

**Keywords:** Design Fiction, Experiential Futures, Posters from the Future, Space Travel, Worldbuilding.

---

**Stuart Candy:** Tell me about JPL's series of posters from the future of space travel.

**David Delgado:** A while back, a famous scientist was planning on coming to the Jet Propulsion Laboratory, and so the Exoplanet Exploration Office asked us to do something to celebrate the diversity of planets that were being discovered. There are thousands of them, and they have all kinds of crazy characteristics that are super interesting. Some rain molten glass, some have two suns, some are considered diamond planets, some are just big gassy giants. Naturally, we wondered what it would be like to go there, and we thought travel posters would be a fun way to showcase different planetary characteristics (Figure 1). So we went to the 1930s, '40s style of illustrated travel poster, and met with scientists to make sure that each one was based on a scientific foundation. But at the same time we wanted it to be joyful. We also wanted to kind of plant that seed: *Maybe we can really go to these places.*



**SC:** So where did this idea come from? There's been a lot of activity at the intersection of design and futures over the last decade.

**DD:** Yeah! We sort of fell in love with the idea of imagining these futures, and we made the first few posters. And then Dan Goods and I spoke at the AIGA Conference, and after speaking we were killing some time, and went and saw this crazy futurist — you, Stuart — talking about this sort of experiential futures campaign to raise people's attention. And there was also this cone of possibilities diagram that you showed on the screen, which really helped to crystallise the idea for us, and gave us a way to talk about it strategically and show other people (Figure 2). We may be at the very tip of that cone right now, and going to these future worlds is somewhere farther out in that flurry of many different dots, but the whole notion is to continue doing things that will get us closer to that. How we get there, we don't know, but we know that we need to keep on progressing. And so it was really a catalyst to the way that we thought.

**SC:** That's great to hear!

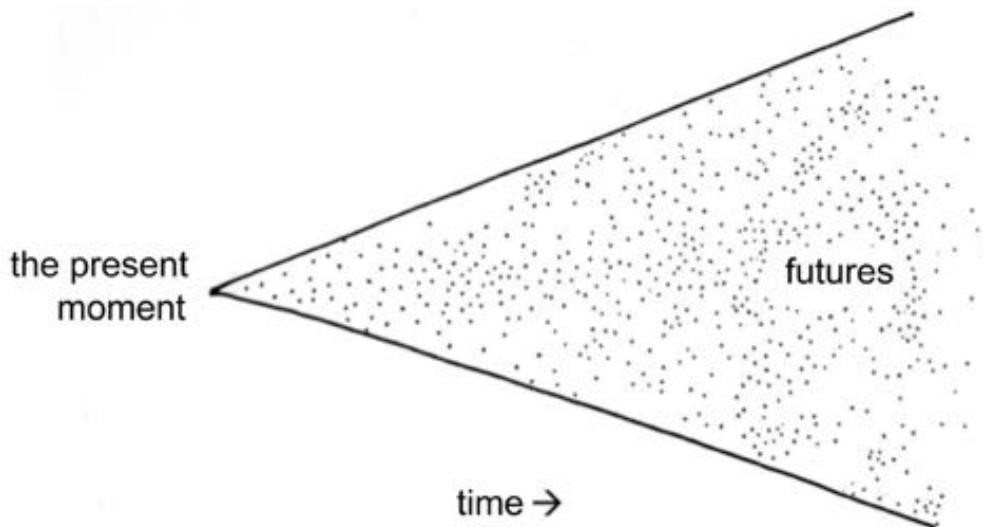

Candy 2010, p. 34  
(after Hancock & Bezold,  
Voros, and others)

*Figure 2.* Cone of possibility space

**DD:** And then, apparently, everybody liked it. There were 1,200,000 downloads in one week when we first released the whole set. It was kind of nuts.

**SC:** Amazing. And the details of the posters were based on the state of the science, what is known about these different planets.

**DD:** That's right, and we focused on one special thing about each faraway planet, following the model of the original travel posters themselves. You're going to be in a forest, or the desert. We allowed people's imaginations to grow from there.

**SC:** How did it come about?

**DD:** It was internal. The design brief was to decorate a hallway — that’s where these came from, the request to decorate a hallway.

**SC:** [laughs] I love that. Instead, you ended up decorating a million hallways.

**DD:** Right! What’s cool is that it grew organically. We had three posters, meant for internal use, and everybody started liking it, and the director of JPL fell in love with it. The director was on vacation at the Grand Canyon, and sent an email saying, “Look at this calendar – let’s do one for the posters!” We went from having three to doing another nine very quickly.

**SC:** So then you did stickers?

**DD:** Yes. The posters happened, then we had a change of director of JPL, and a huge workload going on at the time. There was a request for us to give a gift to the Laboratory itself, to all of the JPLers. It was kind of an effort to raise morale; at least, that was our approach.

Given that a lot of people are working super hard on really amazing projects, we looked at each of those projects and imagined: what could this lead to? So we decided to create these stickers for clubs and societies from the future that you could join when interplanetary travel is possible, but representing what’s currently being worked on.

Each person at JPL got four sets of twelve different designs, like a swag pack that they could hand out to their friends and family, and that would give them a way to tell the story about what JPL is doing, and feel proud about their own work and contribution.

Strategically, the clubs are storytelling devices. At JPL you’ll see people put the stickers all over their computer, or people driving around with just an E, for Earth, like the European bumper stickers (Figure 3). When you’re travelling throughout the solar system, you need to represent where you’re from! It’s all done with a wink and a smile.

There’s the Secret Order of Dark Matter and Dark Energy.

There’s a big push to identify near-Earth asteroids and make sure that Earth stays safe from impact, so we created the Asteroid Patrol.

One was inspired by the 40th anniversary of the Golden Record, so we created the Proud to be Human Club. The Golden Record and Pioneer had all these things about Earth, so we merged them together. There’s a lot of reasons to be proud to be human, and let’s just celebrate that for a second.

Enceladus is a moon of Saturn. It’s also an ice covered planet that shoots out geysers of water. And so since it’s covered in ice, we have the Enceladus Hockey League.

**SC:** These are great.

**DD:** We had to think about Earth in a different perspective too, as our original home, that we will always consider the first place. It’s this motherhood that we are coming and going from; a Buckminster Fuller-inspired, “Spaceship Earth” idea.



Figure 3. Earth bumper sticker from the project *Clubs for the Modern Explorer*, an internal gift from the JPL Director to Lab employees

**SC:** I bet they were a hit.

**DD:** Yeah, they were a huge hit. Everybody loved them.

**SC:** So the clubs and associations thing actually came out of having done some worldbuilding already, and going, “Well, if this existed, then so would these...”

**DD:** Right. It came from one of the posters, actually, about Titan, a moon of Saturn. One of the great things about Titan is there’s these big seas of hydrocarbons — think of like, liquid nitrogen, but it’s liquid methane. So the design was this beautiful image of the seas with Saturn in the background (Figure 1). This part never made it into the poster, but we were kind of imagining what the boat rental place would be, and the logo for it — and that started us thinking, maybe we could look at logos as a device to communicate something. If that exists, travelling around between planets, what are some cool clubs that you could join in that world?

**SC:** That’s really interesting. So how would you describe the use of experiential scenarios or design fiction at JPL, what has it done for you?

**DD:** Well, for one thing it took the conversation out of the present, and allowed people’s imaginations to become involved, thinking about not only what kinds of things are happening now, but where they may lead in the future.

**SC:** That doesn’t happen regularly?

**DD:** It does happen regularly, but it's usually positioned within the focus of creating new missions. It's strategic in a different way.

The reason we really gravitated towards it is because it allowed us to create a motivational tool. For people at JPL it sort of reinforced the reason they started working there in the first place: they want to do something big, contribute to humanity, be at the cutting edge. Using the future to help motivate people became a powerful way to communicate internally. If you're part of space exploration, you are part of a group building this continuous series of steps that will lead to something very special.

I think once the poster downloads happened, we realised that it was much bigger than communicating internally. There is this shared public dream of being up in space — it has been in science fiction for a very long time — but these places are real. These designs brought them one step closer, gave them more power.

It was this whole experiment in understanding the value of using the future as a tool for the imagination.

## Correspondence

David Delgado  
NASA JPL  
USA

[http:// www.davidjdelgado.com](http://www.davidjdelgado.com)

E-mail: [David.J.Delgado@jpl.nasa.gov](mailto:David.J.Delgado@jpl.nasa.gov)

## Notes

This text is an edited transcript of conversations that took place in July 2018. The *Clubs for the Modern Explorer* project was created for JPL internal distribution only and was not paid for at government expense.

# Post-Island Futures: Designing for Uncertainty in a Changing Climate

Lizzie Yarina  
MIT Urban Risk Lab  
USA

## Introduction: Unstable Futures

In contemporary climate change discourse, Tuvalu is represented as a ‘sinking nation’ whose apocalypse has been predetermined by rising seas. However, unpacking climate change uncertainties in the context of cyclical Tuvaluan histories shows multiple possible futures that Tuvaluans may inhabit. Historically, Tuvaluan peoples were mobile, canoeing between islands for trade and war, or seeking new ground when their atolls’ fragile water supplies ran dry. Atolls, coral islands rising only a few meters above sea level, are fluid as well; corals adapt to changing sea levels by growing upwards towards the light. Re-considered as a fluid entity, Tuvalu might survive the rising seas, and atoll communities and geographies could be bolstered through hybridized interventions.

In the context of migratory populations and unstable geographies this project proposes design as instigator of multiple possible futures, unfolding in multiple timelines that travel deep into time and space, as a way of de-colonizing and re-politicizing Tuvalu’s “apocalyptic imaginaries” (Swyngedouw, 2011). Paralleling a future studies framework of alternative futures, this architecture/urbanist design research project offers possible deep future narratives for Tuvaluan atoll-dwellers through a process similar to “rigorous imagining” (Candy, 2010; see also Miller, Shapiro, & Hilding-Hamann, 2008).

Rejecting the notion of a singular solution, the architect/urbanist instead frames multiple possible interventions across several scenarios through the propagation of architectural ‘seeds’ which ‘grow’ territory to accommodate Tuvalu’s uncertain futures. Through a discussion of these speculative design scenarios and strategies, this essay seeks to explore the potentials of designing for multiple possible futures in the context of a human-altered climate. The essay also shows how future thinking logics have been leveraged in this design process, suggesting possible further collaborations between architecture, urbanism, and futures studies.

## Climate Change Uncertainty: Re-politicizing a “Sinking” Tuvalu

Tuvalu, a tiny archipelagic nation of nine coral atolls located in Polynesian Oceania, has come to serve as a global symbol for the risks climate change poses to humanity. Like other low-lying island states, it faces not only natural disasters (i.e. cyclones) and resource constraints (i.e. fresh water) stemming from anthropogenic climate change, but the potential loss of habitable land as corals die and sea levels rise. With the submersion of the nation’s physical space, Tuvalu’s status as a nation-state is endangered. Deemed a ‘sinking nation’ (Park, 2011), Tuvalu has become part of the climate change apocalyptic imaginary, in spite of uncertainty surrounding specific greenhouse gas impacts on atoll systems. While climate change is certainly real and happening, uncertainty regarding from specific manifestations on the ground arise from the inability of models to exactly

replicate the complexity of the earth's atmospheric systems, and the rapidly evolving nature of climate change science and policy; even the Intergovernmental Panel on Climate Change (IPCC) acknowledges huge gaps in our collective scientific knowledge (IPCC, 2014; Deser, Phillips, Bourdette, & Teng, 2012). Furthermore, as Dator's First Law of the Future notes, "'The future' cannot be 'predicted' because 'the future' does not exist" (Dator, 1995). The degree of sea level rise in Tuvalu in the next century and its impact on atoll geographies depends on many factors, including the decided uncertainty of how the world—the collection of actors including nation-states, corporate entities, and individuals—will change its environment-impacting activities.

Tuvalu's recent rise to fame as a "sinking nation" has paralleled its representation as an origin for the environmentally displaced (Gemenne, 2015; Shen & Gemenne, 2011). "Climate refugees" are represented in the media carrying their belongings through waist deep water or marching across barren deserts. The title of "refugee" eliminates the agency of the individual from the conversation; the climate happens to them, and they have no choice but to evacuate. Within the framework of this singular narrative, it has been nearly impossible for Tuvaluans and other atoll nations to develop alternative futures for their archipelago. That this representation has been applied by the outside Western world is additionally problematic, positioning Tuvalu as a tiny pawn in a global narrative in spite of their rich cultural history.

This project seeks to provide de-colonized alternatives for Tuvalu's future (Dator, 2005) away from the fetishized imaginary of a drowning nation. The future visioning process considered in this project seeks to return Tuvalu agency over its own future by creating tools for speculative alternatives which draw on Tuvaluan history and culture. The spectrum of proposals seeks to provide a method for self-determination through the production of alternative, locally-produced futures.

## Testing Futures: Alternative Scenarios

In this project, projected futures deal with future time in two primary ways: through multiple *scenarios* and through *expanded time scales*. Multiple scenarios, set in alternative possible futures, re-politicize (Swyngedouw, 2011) climate change, by taking it from fetishized imaginaries towards a richly complex social issue. This method invites discourse over what climate-changed futures might be, and how we can deal with future uncertainty. Within each future scenario, design interventions deal not with a single moment, but operate in broad swathes of future time-space. They envision not a final condition, but processes and systems that unfold responsively.

While possible futures for Tuvalu are limitless, the current climate science suggests some scenarios as more probable than others. This project uses as a starting point two of these scenarios, with each examining not only different climactic/social events, but also exploring broad ranges of time and space (Figure 1). Playing out these alternative future timelines as semi-fictional narratives frames possibilities for how architectural interventions can advocate for Tuvaluan populations.

*Future A* or 'climate change as usual' looks at a condition of incremental sea level rise, aligning with existing IPCC projections, and extrapolates Tuvalu's existing population boom. Design interventions suggest possible strategies for growing Tuvaluan cultural space both in- and ex-situ (Figure 2).

*Future B* explores a rapid ice-melt scenario, where the catastrophic collapse of major ice sheets results in rapid out-migration and necessitates strategies for defending Tuvalu's claims to territorial waters. Here, the nation is re-imagined as a strategic, collectivized economy (Figure 3).

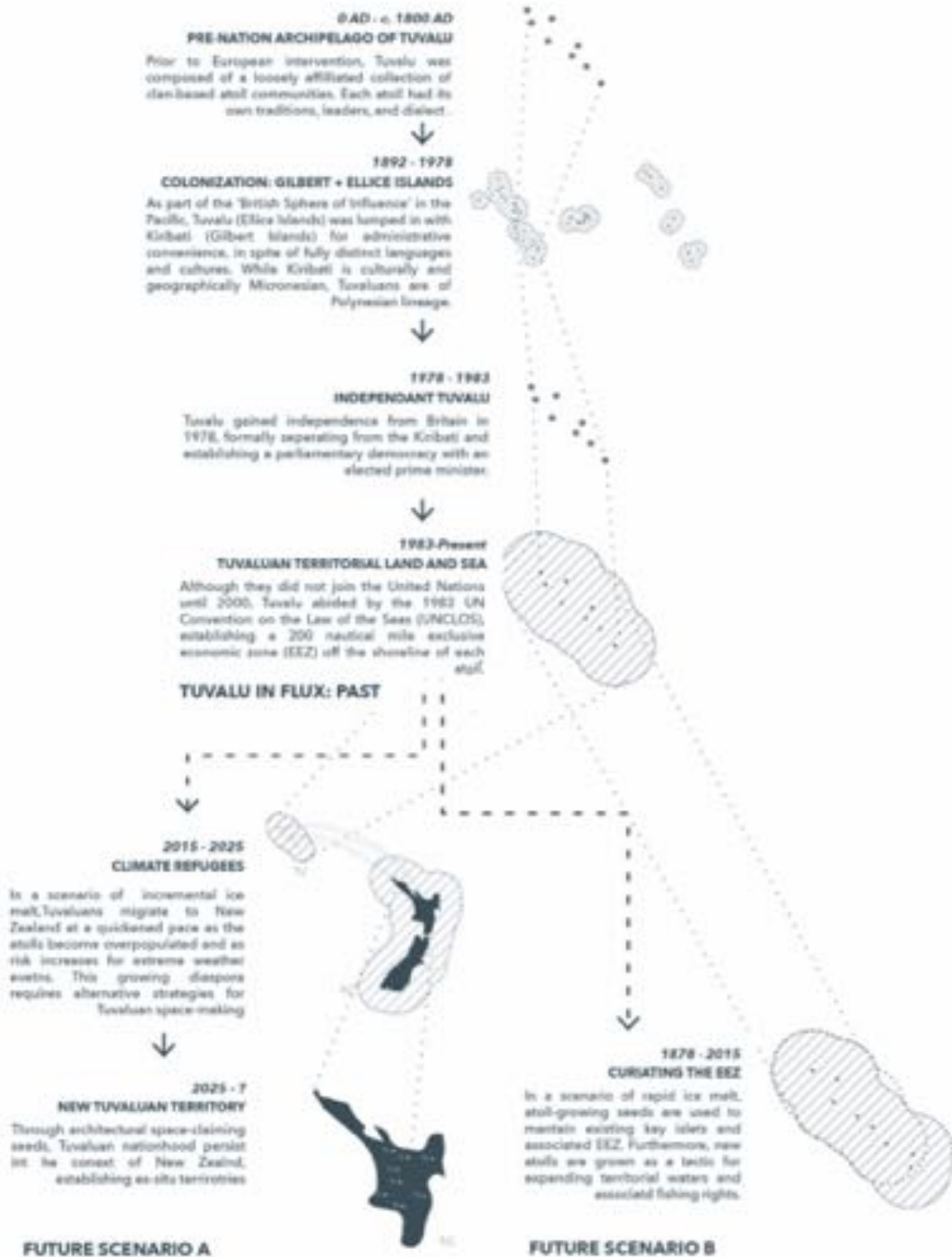

Figure 1. Scenarios-A+B





Figure 3. Scenario-B

Combined, these two scenarios provide a productive comparison with a range of climatological and social impacts. Each scenario explores how architectural seeds might be propagated over time, within Tuvalu and the growing territories of the diaspora (specifically New Zealand), as well as impacts and implications from the scale of architecture to the region. The seeds, scenarios, and research were developed side-by-side and inform one another, such that while the seeds attempt to deal specifically with the scenarios as developed, they also operate strategically in Tuvalu’s larger context of unstable ground and mobile populations.

### ‘Seeding Territory’: Strategies and Tactics

The design proposals encompass a series of small interventions, which by accumulation over time or through broader ripple effects in space serve Tuvaluan futures at much larger scales. The seeds are intended as tools to enable Tuvaluans “to generate and pursue their own diverse preferred futures” (Candy, 2014). Like the atolls Tuvaluans have traditionally inhabited, the ‘seeds,’ (Figures 3 & 4) implemented individually or collectively, accumulate incrementally over time, responding to dynamic contexts of culture and geography. Instead of *building* large scale infrastructures to

blockade against sea level rise or house massive displaced populations, this project instead proposes *growing* responsive architectures and landscapes for fluid ground and mobile populations. As a microstate with limited economic resources, it is essential that Tuvalu strategically leverages what it does have: sovereignty, oceanic territory, coral reefs, fish stocks, cultural independence. The proposed seeds allow the population to benefit broadly from minimal and incremental interventions applied by and for Tuvaluans.

The distinction between the proposed ‘seeds’, which play out on the ground at a human scale, and their larger cultural, social, economic, and territorial aims, draws on Michel de Certeau’s notion of “strategies and tactics.” De Certeau distinguishes between *strategies*, the “manipulation of power relationships” at a site-specific macro-scale, and *tactics* or “calculated actions” without specific sites which operate in response to immediate conditions (de Certeau, 1984). Instead of placing strategies and tactics in opposition, as governor vs. governed, or organizations vs. individual, or even top-down vs. bottom-up, this project instead proposes a collusion of strategies and tactics in service of a collective agenda. Thus, the tactical activities of placing the architectural ‘seeds’, undertaken by individuals or small groups, can serve larger Tuvaluan agendas as they work toward strategies of creating new economic networks, land-making, cultural space-making, or territorial protection. This ‘tactical strategy’ parallels Van Alstyne and Logan’s (2007) notion of “designing for emergence,” where the top-down hand of the designer is balanced with emergent, self-determining behavior of bottom-up agents.



Figures 4. Combined Scenarios

## Design and Futures

Designers inherently work with the intangible matter of the future: the as-yet-unknown, the projective, the undefined. Through the window of climate change, this project seeks to expand what it means to design with and for uncertain futures. Global warming has become fetishized as a singular narrative: rising sea levels, retreating cities, sweltering, weather-ravaged communities. Recognizing climate uncertainty, alongside a Tuvaluan culture of indeterminate future models, this project advocates a designer role of imagining possible futures mediated through responsive, time-based strategies. These are not specific recommendations or even kits of parts, but rather tools to show how design can be projective and productive, leveraging existing systems and circumstances.

While not emerging directly from futures studies, many of the methods of future-thinking employed in this project parallel recent work in critical futures studies and experiential futures concepts, including constructing experiential *alternative futures* (Candy, 2010; Slaughter, 1993; Inayatullah, 2008) through deep future scenario timelines, and attempting to *de-colonize the future* (Dator, 2005) by suggesting tools to counter the fetishized representations of sinking atolls. The study of tactical 'seeds' and strategic accumulations further parallels Van Alstyne and Logan's model of *emergent design* incorporating both the top-down hand of the designer with emergent bottom-up processes.

Further, through contextualization within longer spans of time, this project explores whether, in the process of design, it is necessary to defer to lived time scales. This is particularly relevant in the case of Tuvalu where temporality is an inherent part of the place. The maps and indexical drawings of this project conceive of the present moment in the history of Tuvalu and Oceania as not a single event, but as part of a long duration of evolving geophysical, climatological, and human systems. This parallels a futures studies view where the past, present, and future are deeply interconnected (Slaughter, 1993). The window of time contextualizing the project is opened up, considering timescales from the last ice age to the impending collapse of our current glaciers. I hypothesize that designing for futures, such as those prompted by climate change risks, must also include a study of pasts, of moments where humanity and environment, population and geography have previously collided.

The crisis of anthropogenic climate change (itself a result of neglecting to consider possible futures) requires critical future-thinking surrounding catastrophic environmental risks, together with innovation in the process of designing built environments. By studying how architectural and urban design proposals might intervene in potential future narratives for the vulnerable island-nation of Tuvalu, this project advocates for built environment design protocols that engage with uncertainty and emergence, alternative futures, and self-determination.

## Correspondence

Lizzie Yarina  
Researcher  
MIT Urban Risk Lab  
PhD Student  
MIT Department of Urban Studies and Planning  
USA  
E-mail: lizziey@mit.edu

## Notes

## References

- Candy, S. (2010). *The futures of everyday life: Politics and the design of experiential scenarios* (PhD Dissertation). University of Hawai'i at Mānoa. doi:10.13140/RG.2.1.1840.0248
- Candy, S. (2014). Why Christchurch should not plan for the future. In B. Bennett, J. Dann, E. Johnson, & R. Reynolds (Eds.), *Once in a lifetime: City-building after disaster in Christchurch* (pp. 84-89). Christchurch, NZ: Freerange Press. Retrieved from <https://www.researchgate.net/publication/305281472>
- de Certeau, M. (1984) *The Practice of Everyday Life* (S. Rendall, Trans.). Berkeley: University of California Press.
- Dator, J. (2005) [1975]. De-colonizing the future. *Journal of Futures Studies*, 9(3), 93-104. Retrieved from <https://jfsdigital.org/wp-content/uploads/2014/01/93-E04.pdf>
- Dator, J. (1995). What futures studies is, and is not. Hawaii Research Center for Futures Studies. Retrieved from <http://www.futures.hawaii.edu/publications/futures-studies/WhatFSis1995.pdf>
- Deser, C., Phillips, A., Bourdette, V., & Teng, H. (2012). Uncertainty in climate change projections: The role of internal variability. *Climate Dynamics*, 38(3-4), 527-546. doi:10.1007/s00382-010-0977-x
- Gemenne, F. (2015, April 24). Anthropocene and its victims [Lecture]. Harvard University Kennedy School.
- IPCC (2014). *Intergovernmental Panel on Climate Change Fifth Assessment Report*. Cambridge University Press. Retrieved from <http://www.ipcc.ch/report/ar5/>
- Inayatullah, S. (2008). Six pillars: Futures thinking for transforming. *Foresight*, 10(1), 4-21.
- Miller, R., Shapiro, H., & Hilding-Hamann, K. E. (2008). *School's Over: Learning Spaces in Europe in 2020: An Imagining Exercise on the Future of Learning*. JRC Scientific and Technical Reports. Retrieved from <https://ec.europa.eu/jrc/en/publication/eur-scientific-and-technical-research-reports/schools-over-learning-spaces-europe-2020-imagining-exercise-future-learning>
- Park, S. (2011, May). *Climate Change and the Risk of Statelessness: The Situation of Low-lying Island States*. United Nations High Commissioner for Refugees (UNHCR) Legal and Protection Policy Research Series. Retrieved from <https://www.unhcr.org/en-us/protection/global-consult/4df9cb0c9/20-climate-change-risk-statelessness-situation-low-lying-island-states.html>
- Shen, S., & Gemenne, F. (2011). Contrasted views on environmental change and migration: the case of Tuvaluan migration to New Zealand. *International Migration*, 49(S1), e224-e242. doi:10.1111/j.1468-2435.2010.00635.x
- Slaughter, R. A. (1993) Futures concepts. *Futures*, 25(3), 289-314.
- Swyngedouw, E. (2011). Depoliticized environments: The end of nature, climate change and the post-political condition. *Royal Institute of Philosophy Supplement*, 69, 253-274. doi:10.1017/S1358246111000300
- Van Alstyne, G., & Logan, R. K. (2007). Designing for emergence and innovation: Redesigning design. *Artifact* 1(2), 120-129.



# Starting at the End: A Journey in Time

Tony Fry  
University of Tasmania  
Australia

**Keywords:** Anthropocene, Design Futuring, Sustainment.

A fundamental conclusion that I have reached from my experience as a designer, educator and theorist is that it is now impossible to constitute a viable future for humanity without design. Three key questions follow from stating this conclusion: what would actually constitute a viable future? How is humanity to be understood now? And, how is design to be understood? Brief answers to these questions will be given and a list of prerogatives suggested to the futural designer.

As others and I have argued, the concept and process of ‘the Sustainment’ provides a clear response to what would actually constitute a viable future. It embraces both the continuity of life itself and within it the changing nature and plurality of human life.<sup>1</sup> So positioned, the Sustainment should not be confused with sustainability, as it dominantly sustains the unsustainable. Rather, it denotes a post-Enlightenment intellectual project and agenda (one of or beyond the scale of the Enlightenment) to deal with ‘the world’ that modernity, the Enlightenment and the linked ‘dark colonial underside’ brought into being. The Sustainment needs to be viewed as conceptual emergence, a situated process and unending project. In essence the Sustainment is ‘a work’ of becoming futural. As such, places to begin can be found. It does not equate to a praxis that is ‘to hand’, but rather one to be created. It is not a utopian vision, for viability does not imply perfection or the fully resolved, but a qualitative continuity of life predicated upon ontological transformation of human modes of being-in-the-world (which does not simply equate to being in the Anthropocene).<sup>2</sup>

The question of how humanity is to be understood now is at the core of a very topical, complex and growing debate on post-humanism, the human, the post-human, and inhuman (see for example, Herbrechter, 2013). While summarising this debate is a task beyond the scope of this essay there are few qualifying remarks that need to be made.

It is clear that no consensual view will emerge out of this debate, moreover it can be expected that differences will increase (for example, between critical and techno-centric post-humanism). Likewise, the Eurocentric bias of the debate requires pointing out as it excludes/marginalises indigenous ontologies, which implies they are deemed to be of no future consequence and are fated to completely disappear by being ‘modernised’. One could also note that the totalising concept and language of humanism, humanity and the human have always been, and continue to be, irredeemably problematic. Correspondingly, the existing and increasingly plural nature of ‘the human’ and extant and coming forms of the ‘inhuman’ begs much more careful analysis. Likewise, considerations — cosmological and ontological — of difference beg more attention.

As for how design is to be understood futurally, I propose design as:

- (i) An ontological characteristic of ‘human being in difference’, that is, prefiguration is intrinsic to all modes of ‘our’ being and always has been — this is a well-rehearsed position and argument that I and many others have put forward (Fry, 2012); and,

- (ii) A range of restrictive professional practices that in their divisions of labour and knowledge, economic conduct and modes of territorialised professionalisation have diminished the general perception and potential of design as an ethical agent of affirmative transformation ('the good' becomes the process of the Sustainment).

The realisation of the imperative of the Sustainment and the continuity of the human in difference cannot be attained by design as it is – as a service provider to the unsustainable and the advancement of the inchoate project of the techno-thanatological inhuman. Mostly unwittingly, designing and the designed are deeply implicated in the creation of the structural unsustainability of the world of human material and immaterial fabrication (the Anthropocene). The negative biophysical and atmospheric impacts of this action are now implicated in the instigation of the planet's sixth extinction event (Kolbert, 2014). Conversely and consciously, designing and the designed have now become a major means to counter this situation. But this is only possible if design is completely transformed, for as Einstein famously remarked: "you can't solve a problem with the thinking that created it". *Ergo*, for design to be futural (that is, for [the] Sustainment), it has to be other than design thinking and practice currently is. The gargantuan challenge hereby becomes the ontological transformation of what 'we' are, and this issue returns us to the nature of the human and design transformed.

Here are six prerogatives offered up for consideration to the designer and futurist:

## A Confrontation with the End

'Defuturing' names the nature of the agency of the unsustainable. In doing so, it directly manifests a process that brings the assured finitude of our species nearer. As such, it also places the loss of biodiversity that underpins the prospect of a sixth extinction event in a wider context — so what threatens is acknowledged as greater than the loss of biodiversity. As has been argued, for example by Claire Colebrook (2014), the recognition that our species is putting itself in a terminal condition is potentially the most powerful incentive for us to act otherwise. Yet a strange situation now generally obtains in Eurocentrically-directed cultures: at one extreme is the widespread propensity to ignore or deny the assumed distant danger of 'the end of the human'; at the other is an absolute faith in a giving over to technology not to save us but to make our biological substrate, our body, redundant. This is the lunatic endpoint of artificial intelligence: complete 'singularity'. Between the two is a simple failure to realise there is a danger. The challenge thus becomes the creation of a way of making present the prospect of 'the end' in a life-affirming way. The zest for life, as Heidegger made clear with his notion of 'Being-towards-death' (Heidegger, 1962, p. H234) is predicated upon the very recognition of mortality. The end of *Homo sapiens* is writ large.

## End Time

Writing on Nietzsche, Bernd Magnus pointed out that 'we' are chronophobic – we fear time and live with an illusion of permanence (Magnus, 1978, pp. 190-95). Moreover, time is dominantly viewed as a measure of the duration of change and as a dimension. By implication, this means it is *the marking of the moments within that event in which change occurs*. For Aristotle time was nothing but the event of change. Physics and philosophy are in dialogue on time and its relative relation to space and change. Popular perceptions are otherwise. Time is viewed as the unit of measure, linear and as duration. Consequently, the future and finitude are misperceived. The future is viewed as a void waiting to be filled with that taken to it. Whereas a more appropriate and accurate view is of an obstacle course – one populated with 'things' that our species and natural events has thrown into it. To grasp this is to recognise the future contains things gifted from the past as it travels towards us. For example, the anthropogenically accelerated global warming is produced

by an accumulation of greenhouse gas emitted from the past (including the Industrial Revolution), added to by those arriving from the present, all sending climate change towards the planet of the future. Recognising ‘we’ are never anywhere but at that point of departure and arrival that is now — what we do now is critical and decisive to making the ‘event now in which time occurs’. ‘We’ need to act in time (the medium constituted by the event) and with urgency, as what is being thrown into the future is taking the collective event of our Being away — our time is being lost.

## **Economy After Economy**

Economic collapse is unavoidable unless there is an absolutely fundamental change of the mode of material exchange upon which the global economy rests. Currently the entropic trajectory of the economic status quo is already totally determined. The equation is straightforward: finite and stressed planetary resources + global population increasing by 50% by 2100 with +/- 80% of this population engaged in hyper-consumption. This equation sits on a bed of insecurity as the impacts of climate change increase (and with it a deep crisis of food security), as geopolitical insecurity and conflict conform to expectations and escalate. Added to this situation is the potential for new forms of inequity as the power of mega-regions displaces and fragments nations, together with the technological fracturing of any kind of unified notion of a human being, and the possibility of pandemics.

In over-viewing the state of the global economy, Bernard Stiegler has argued ‘we’ currently live by, in and with an economy of stupidity (Stiegler, 2015). This situation epitomises the crisis of crisis in so far as the very appearances of asserted economic success are actual indicators of the crisis being unseen. Bringing together Stiegler’s view of consumption as ‘creative destruction’, Naomi Klein’s notion of ‘disaster capitalism’ (Klein, 2007) and my own thoughts on ‘normality as the normative of concealment’ (Fry, 2004, p.154), one can conclude that the condition of privilege to which the underprivileged aspire is but an anesthetized nightmare from which the world will wake. Even if we beings could magically establish a global economy based upon modesty and equality (a vital ambition), ‘we’ would still be unsustainable. Yet time would have been bought and the best case would have arrived.

## **Learning to Imagine (Again)**

Central to the Sustainment is the recreation of the ability to imagine beyond psycho-colonisation from the constant image assault of techno-culture and its associated techno-sphere. What glitters here in the darkness (of unseeing) coming from the plasma screen of an apocalyptic commodity-filled wasteland (literally) is furnished by the creative industries — sadly a place of the wished-for *normality* of the many. In this world of structural unsustainability, there can be no possibility of contemplating even the idea of another way to be; let alone plural forms of (an)otherness. In the face of such a fate there is no future for the ‘us’ without the liberatory potential of imagination (as projective(s) coming from the few and as seductive(s) experienced by the many). Withdrawal, provocation, a confrontation with darkness, stimulation, desire, time, fiction — a space in which imagination has to be constructed: yet another challenge.

## **The Impossible**

Central to the Sustainment is gaining an appreciation of engaging with the impossible: what has to be contemplated and acted upon is impossible. The task is beyond our abilities and reach. From all that can be seen to weigh down upon us, the plural forms of our fate are not yet sealed. We cannot continue to be without saying no. But how can it be said? The answer resides in our

unknowing. The impossible is determined by (our) knowledge. There are maybe absolute empirical conditions of limitation but they are not known beyond the limits of what we know at the moment or can expect to know in the future. Consider this: if you — by imagination — were to converse with a person in the distant past, or even a few hundred years ago, and were to tell them of some of the things people of the present can do, experience, live, you would exceed that person's imaginative reach. You would be asking them to imagine the unimaginable, the impossible.

In the crisis of now, the impossible has to be imagined. The question becomes: how and where do 'the they' (the who) commit to do this and where do they place themselves? Whatever the answer to this question, it will not be in the cultural, techno-science institutions or innovation factories of the present (which is to say, action has to go beyond description, deconstruction, commentary, the instrumental and the currently conceived economic). Moreover, the task can be expected to go into, and come to, our conditions of crisis, be intergenerational, go unrewarded, take time to progress, and even more time to be recognised. We depend on the yet unknown — and not currently imagined.

## Recasting 'Us'

Without question, humanity is in an increasingly critical situation. As argued, this crisis is not fundamentally environmental or identifiable by any other external situation (although as seen, many of these situations are critical). Certainly, the discourses of sustainability, including sustainable design, are totally incapable of overcoming it. What becomes more apparent by the day is that 'we' are the critical situation in three ways: what we do as unsustainable beings, in number and action; what we are becoming by misdirection, abandoned and transformed; and by what we can define, and thereafter by intent (ontological design) remember ourselves to be. Viewed from this present, ethically we are facing a futural dilemma of having to define the human(s) we need to become in order to continue to be.

## Finally, To Reconnect with the Sustainment and Design

It is obvious that progressive instrumental design practices are necessary, but are in no way sufficient to the challenges before us. Existing restrictive design knowledge, education, practices and services (including 'sustainable design'), as they support the status quo, are utterly insufficient and add to structural unsustainability.

The remaking of design cannot be divided from either the project of Sustainment (as the key intellectual force and process of futuring), or from contesting and ontologically assisting in the transformation of the human, to become more plurally human. To do this, anthropocentrism requires us to be inter-culturally engaged as a collaboration of human difference, a being-in-the-world that respectfully posits authority to the 'undeveloped' over the 'over-developed'. Such action also has to reject the telos of a post-evolutionary 'technological' designing of human being(s). In this respect it looks like difference will go beyond biology, ethnicity and the ontotheological to divide abandoned humanity and the post-human human from the technological inhuman.

## Correspondence

Tony Fry  
Professor  
University of Tasmania, The Studio at the Edge of the World  
22 Benjamin Street, Trevallyn, Tasmania 7250  
Australia  
E-mail: [anthony.fry@utas.edu.au](mailto:anthony.fry@utas.edu.au)

## Notes

1. As such the Sustainment poses a counter discourse to techno-inhumanism and the advocates of synthetic life.
2. These remarks are a gloss on my writing on the Sustainment in works referenced below and in summary on my studio website: [www.thestudioattheedgeoftheworld.com](http://www.thestudioattheedgeoftheworld.com)

## References

- Colebrook, C. (2014). *Death of the posthuman*, Ann Arbor, MI: Open Humanities Press.
- Fry, T. (2012). *Becoming human by design*. London: Berg.
- Fry, T. (2004). The voice of sustainment: Design ethics as futuring. *Design Philosophy Papers*, 2(2), 145-156.
- Herbrechter, S. (2013). *Posthumanism: A critical analysis*. London: Bloomsbury.
- Heidegger, M. (1962) [1926]. *Being and time* (J. Macquarrie & E. Robinson, Trans.). Oxford: Blackwell.
- Klein, N. (2007). *The shock doctrine: The rise of disaster capitalism*. New York: Henry Holt.
- Kolbert, E. (2014). *The sixth extinction*, London: Bloomsbury.
- Magnus, B. (1978). *Nietzsche's existential imperative*. Bloomington: Indiana University Press.
- Stiegler, B. (2015). *States of shock: Stupidity and knowledge in the twenty-first century* (D. Ross, Trans.). Cambridge: Polity.

## Further Reading

- Fry, T. (1994). *Remakings: Ecology/design/philosophy*, Sydney: Envirobook.
- Fry, T. (1999). *A new design philosophy: An introduction to defuturing*, Sydney: UNSW Press.
- Fry, T. (2009). *Design futuring: Sustainability, ethics and new practice*. Oxford: Berg.
- Fry, T. (2011). *Design as politics*. Oxford: Berg.
- Fry, T. (2015). *City futures in the age of a changing climate*. London: Routledge.
- Fry, T. (2017). *Remaking Cities, An Introduction to Urban Metrofitting*, London: Bloomsbury



# DESIGN AND FUTURES

**CANDY & POTTER, Editors**

“Designers and futurists, it turns out, have a great deal in common. This mutual recognition is reaching critical mass as each comes to appreciate how their respective traditions have much to offer to making urgent change in the world, and even more so, together.”

— from the Editors’ Introduction

This landmark collection of essays, manifestos and peer-reviewed articles documents the cutting edge of ‘design futures’ discourse and practice around the world. First published as back-to-back volumes in the open access *Journal of Futures Studies*, the present compilation preserves the original formatting while unifying all 30 pieces from both volumes between covers for the first time. Topics range from worldbuilding and curriculum design to temporality and decolonisation, as well as new methods and processes that build on over a decade of experiential futures, speculative design and related practices. It will be an essential reference for anyone working or studying in either field.

*Contributions by 49 leading scholars and makers*

Danah **ABDULLA** • Ahmed **ANSARI** • Paola **ANTONELLI**  
Tina **AUER** • James **AUGER** • Nik **BAERTEN** • Ralph **BORLAND** • Tim **BOYKETT**  
Anne **BURDICK** • Stuart **CANDY** • Ece **CANLI** • Kuo-Hua **CHEN**  
David **DELGADO** • Alida **DRAUDT** • Jake **DUNAGAN** • Tony **FRY**  
Nik **GAFFNEY** • Jj **HADLEY** • Julian **HANNA** • Dan **HILL** • Jeanne **HOFFMAN**  
Ryan **HOGAN** • Jamer **HUNT** • Anab **JAIN** • Mahmoud **KESHAVARZ** • Matthew **KIEM**  
Lucy **KIMBELL** • Kelly **KORNET** • Maja **KUZMANOVIC** • Ramia **MAZÉ**  
Alex **MCDOWELL** • Timothy **MORTON** • Mugendi K. **M’RITHAA** • Leticia **MURRAY**  
Pedro **OLIVEIRA** • Stefanie A. **OLLENBURG** • DK **OSSEO-ASARE** • Karla **PANIAGUA**  
Cher **POTTER** • Luiza **PRADO** • Aaron **ROSA** • Tristan **SCHULTZ** • Gregory **STOCK**  
John A. **SWEENEY** • Maya **VAN LEEMPUT** • Julia Rose **WEST**  
Lizzie **YARINA** • Liam **YOUNG** • Leah **ZAIDI**

**Tamkang University Press**

Taipei, Taiwan

